

Report on the investigation of

a fatal accident on board

Arco Adur

on the River Medway

25 February 2003

Marine Accident Investigation Branch
First Floor
Carlton House
Carlton Place
Southampton
United Kingdom
SO15 2DZ

**Report No 23/2003
September 2003**

Extract from
The Merchant Shipping
(Accident Reporting and Investigation)
Regulations 1999

The fundamental purpose of investigating an accident under the Merchant Shipping (Accident Reporting and Investigation) Regulations 1999 is to determine its circumstances and the causes with the aim of improving the safety of life at sea and the avoidance of accidents in the future. It is not the purpose to apportion liability, nor, except so far as is necessary to achieve the fundamental purpose, to apportion blame.

Note

This report is not written with liability in mind and is not intended to be used in court for the purpose of litigation. It endeavours to identify and analyse the relevant safety issues pertaining to the specific accident, and to make recommendations aimed at preventing similar accidents in the future.

CONTENTS

	Page
GLOSSARY OF ABBREVIATIONS AND ACRONYMS	
SYNOPSIS	1
SECTION 1 - FACTUAL INFORMATION	3
1.1 Particulars of <i>Arco Adur</i> and accident	3
1.2 Background to the vessel	4
1.3 Narrative	4
1.4 Environmental information	10
1.5 River Medway	10
1.6 The vessel	11
1.7 Bridge Resource Management	21
1.8 The ISM Code	24
1.9 ISM implementation	25
1.9.1 Audit structure	27
1.9.2 Internal audits	28
1.10 Safe working practices	29
1.11 Induction process	32
1.12 Alcohol and drugs	35
1.13 Previous incident	35
SECTION 2 - ANALYSIS	37
2.1 Aim	37
2.2 Induction of new staff	37
2.2.1 Handover	38
2.2.2 Guidelines	38
2.3 Operation of hazardous equipment	38
2.3.1 Equipment training	38
2.3.2 Usual procedure	39
2.3.3 Hazard awareness	39
2.3.4 Ergonomics	39
2.3.5 Correct tower operation	39
2.3.6 Good communication	40
2.3.7 Hazard warning	40
2.3.8 Implementing new operational practices	40
2.4 ISM	41
2.5 Control ergonomics	43
2.6 Working and watchkeeping routine	44
2.7 Other recent accidents	44
SECTION 3 - CONCLUSIONS	45
SECTION 4 - ACTION TAKEN	46
SECTION 5 - RECOMMENDATIONS	48

GLOSSARY OF ABBREVIATIONS AND ACRONYMS

'A' class	-	Four identical vessels in the company fleet
AB	-	Able Seaman
ATSB	-	Australian Transport Safety Bureau
COSWP	-	Code of Safe Working Practices for Merchant Seamen
DOC	-	Document of Compliance
DP	-	Designated person
DSSMC	-	Domestic Passenger Ships' Safety Management Code
gt	-	Gross Tonnage
ICS	-	International Chamber of Shipping
IMO	-	International Maritime Organization
ISM	-	International Safety Management Code
kW	-	Kilowatt
m	-	metre
MCA	-	Maritime and Coastguard Agency
MNS	-	Medway Navigation Service
MOD	-	Ministry of Defence
OOW	-	Officer of the Watch
PEC	-	Pilot Exemption Certificate
PSC	-	Port State Control
SMC	-	Safety Management Certificate
SMS	-	Safety Management System
SOLAS	-	Safety of Life at Sea
STCW95	-	Standards of Training, Certification and Watchkeeping 1995
UTC	-	Universal Co-ordinated Time

SYNOPSIS



At 0925, on 25 February 2003, the bosun of the UK registered aggregate dredger *Arco Adur* was fatally injured on board the vessel when she was outbound on the River Medway.

The accident occurred when the aft cargo loading tower on the port side main deck of the vessel was rotated. The bosun, who had not been expecting the aft tower to be operated, became trapped between the aft loading tower reject chute and the port coaming of the cargo hopper.

The bosun and an able seaman were in the process of hanging-off the outhaul wire for the port drag scraper cargo bucket on to the port coaming. This was a normal operation carried out on completion of the discharge of the cargo.

Arco Adur was the only one of four similar vessels in the fleet to use the forward cargo loading tower to assist with hanging-off the outhaul wire on to the coaming. The forward tower was used to lift the wire above the coaming with the assistance of a lifting strop. The tower was then rotated to bring the wire over the coaming so that a crew member could hang the wire over a hook which was attached to the coaming.

Both loading towers were operated from the bridge loading console, from where the towers could be clearly seen. However, the second mate, who was relatively new to the company, had not been instructed in the operation to hang off the outhaul wire and believed, mistakenly, that both cargo loading towers were required.

The Maritime and Coastguard Agency had issued the vessel with her Safety Management Certificate in July 2001. However, the vessel did not have any written procedures for the operation of the loading towers, and the induction procedures were open to misinterpretation by the senior officers of the vessel.

Actions have been taken by the vessel's operator to prevent a recurrence of the accident.

Photograph courtesy of FotoFlite

2



mv Arco Avon (sister ship of Arco Adur)

Photograph 1

SECTION 1 - FACTUAL INFORMATION

1.1 PARTICULARS OF *ARCO ADUR* AND ACCIDENT

Vessel details

Registered owner	:	Hanson Aggregates Marine Ltd
Port of registry	:	Southampton
Flag	:	UK
Type	:	Aggregate suction dredger
Built	:	1988 Appledore Ferguson Shipbuilders Ltd
Classification society	:	Bureau Veritas
Construction	:	Steel
Length overall	:	98.3m
Gross tonnage	:	3498
Propulsion	:	One Mirrlees K Major Mk.3 six-cylinder diesel engine
Propulsive power	:	2940kW
Service speed	:	12.4 knots
Other relevant info	:	Single variable pitch propeller and bow thruster

Accident details

Time and date	:	0925 UTC on 25 February 2003
Location of incident	:	River Medway outbound at Buoy 32
Persons on board	:	Ten
Injuries/fatalities	:	Fatal crush injuries to bosun
Damage to vessel	:	Nil

(Photograph 1- *Arco Avon* – sister ship to *Arco Adur*)

1.2 BACKGROUND TO THE VESSEL

Arco Adur, a 15 year old Class VIII aggregate dredger, is one of 11 vessels operated by Hanson Aggregates Marine Ltd. She is one of the company's four 'A' class vessels. *Arco Adur* operates in and around the southern North Sea, and loads at various dredging grounds. She discharges her cargo on the east and south coasts of England or in other northern European ports. Complete voyages generally last 24 to 36 hours. She frequently visits one of several discharging berths on the River Thames and River Medway. Discharging ports and berths are not planned far ahead, but are chosen according to commercial requirements at the time.

1.3 NARRATIVE

Arco Adur had arrived at Eurowharf discharge berth, Rochester (on the River Medway), at 0420 on 25 February 2003, and began discharging at 0440 from her starboard side.

The discharge operations were completed at 0900. After reporting to Medway Radio her intention to leave the berth, the mooring lines were released at 0910, the vessel swung to port and headed downriver en route to the loading area **(Figure 1)**.

The master was at the helm on the bridge, while the officer of the watch (OOW) the second mate, had 'let go' the mooring lines on the forecastle with the assistance of an able seaman (AB). The bosun had 'let go' the aft moorings.

As *Arco Adur* proceeded along Upnor Reach on the river, toward the right-hand bend, the second mate returned to his position on the bridge. The bridge and accommodation block were situated at the forward end of the vessel, the cargo hopper amidships and the engine and winch rooms were aft.

Meanwhile, in preparation for loading, the AB on the forecastle had made his way aft to the port main deck, and was in the process of hanging-off the port drag scraper bucket outhaul wires to the port coaming of the cargo hopper. This involved lowering a strop with a grapple attached into the cargo hopper, to hook on to the outhaul wires. This strop was then attached to the loading chute of the forward loading tower. The tower was used to assist in lifting and swinging the wires away from the hold. Moving the wires clear of the hold prevented them being damaged by aggregate during the loading operation, and also prevented the aft tower loading chute from fouling the wires **(Figures 2a, 2b, and 3)**.

When the strop had been connected between the chute and the wires, the AB used a portable VHF walkie-talkie radio to contact the bridge and requested that the tower be swung. He used words to the effect, "Can we swing the tower, please?" This operation required the hydraulic power pack, located under the port main deck, to be started from the bridge cargo loading console, and the loading chute of the forward tower to be raised clear of the support cradle, to enable the tower to be rotated.

Figure 1

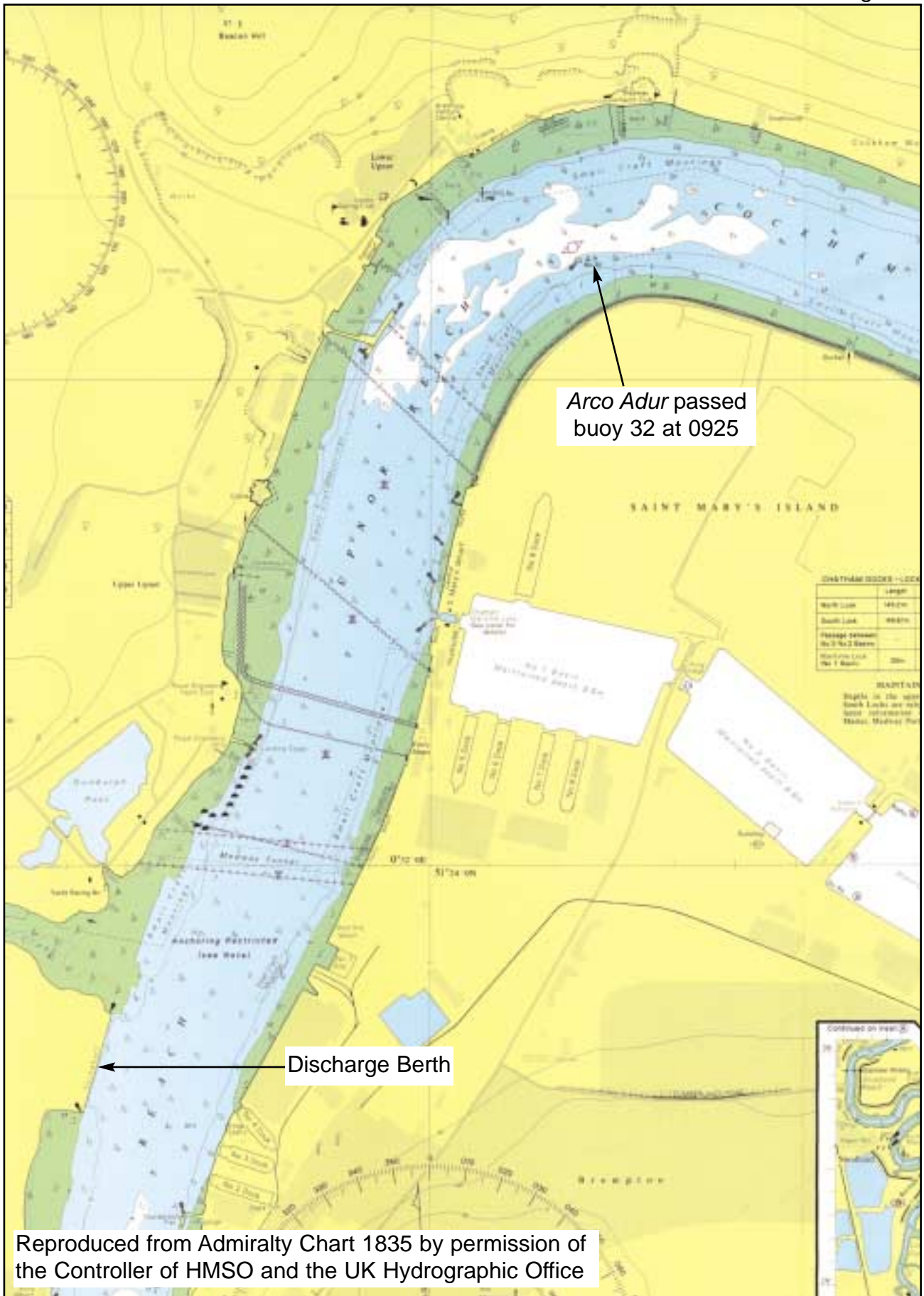

Reproduced from Admiralty Chart 1835 by permission of the Controller of HMSO and the UK Hydrographic Office

Port drag scraper bucket Outhaul wire hanging-off operation

Key:
F.T. Forward tower
A.T. Aft tower
R.C. Reject chute
L.C. Loading chute

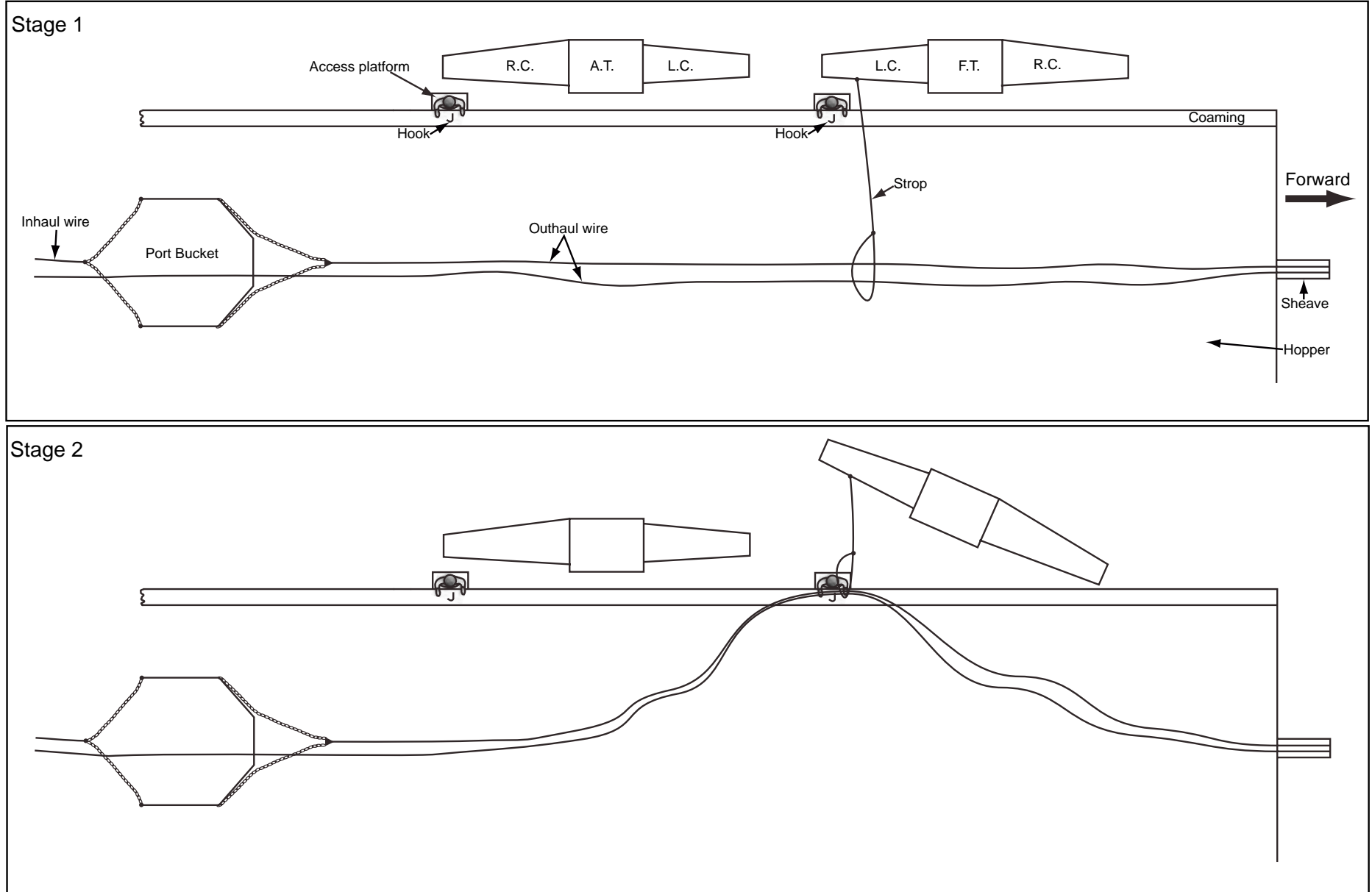
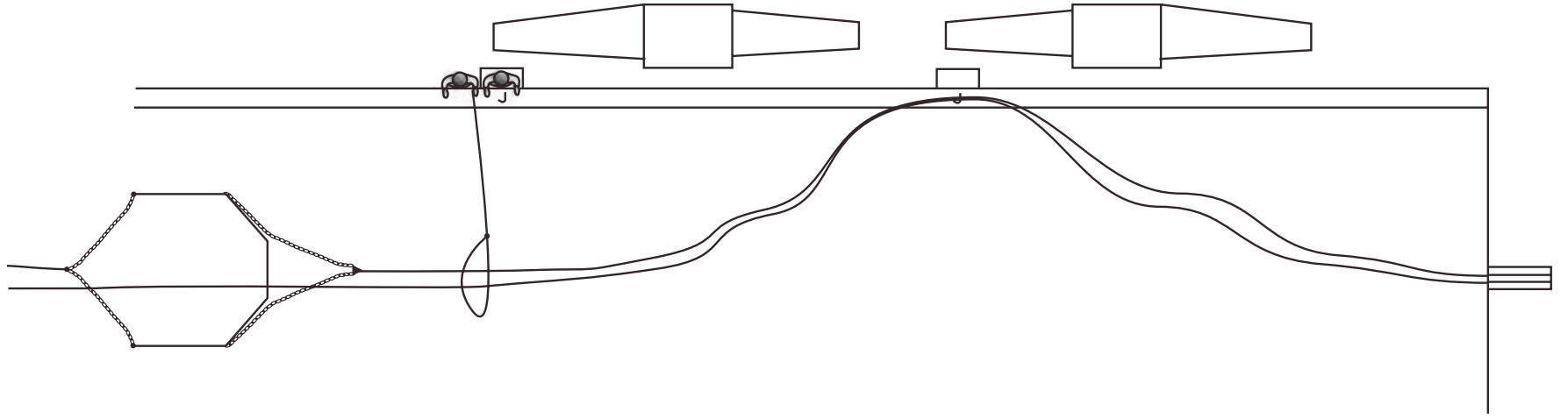

Figure 2a

Stage 3



Stage 4

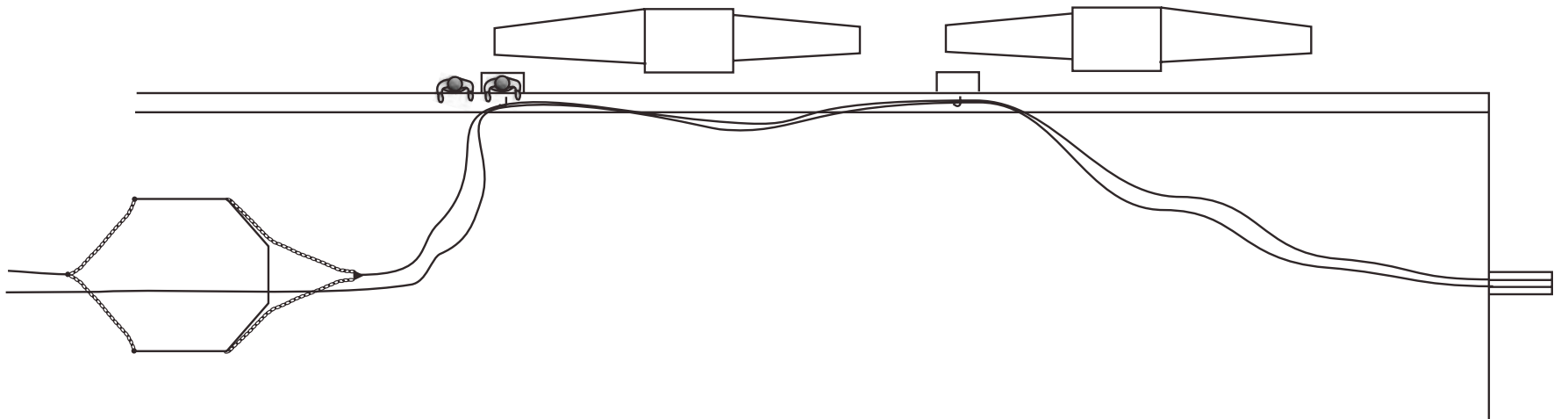
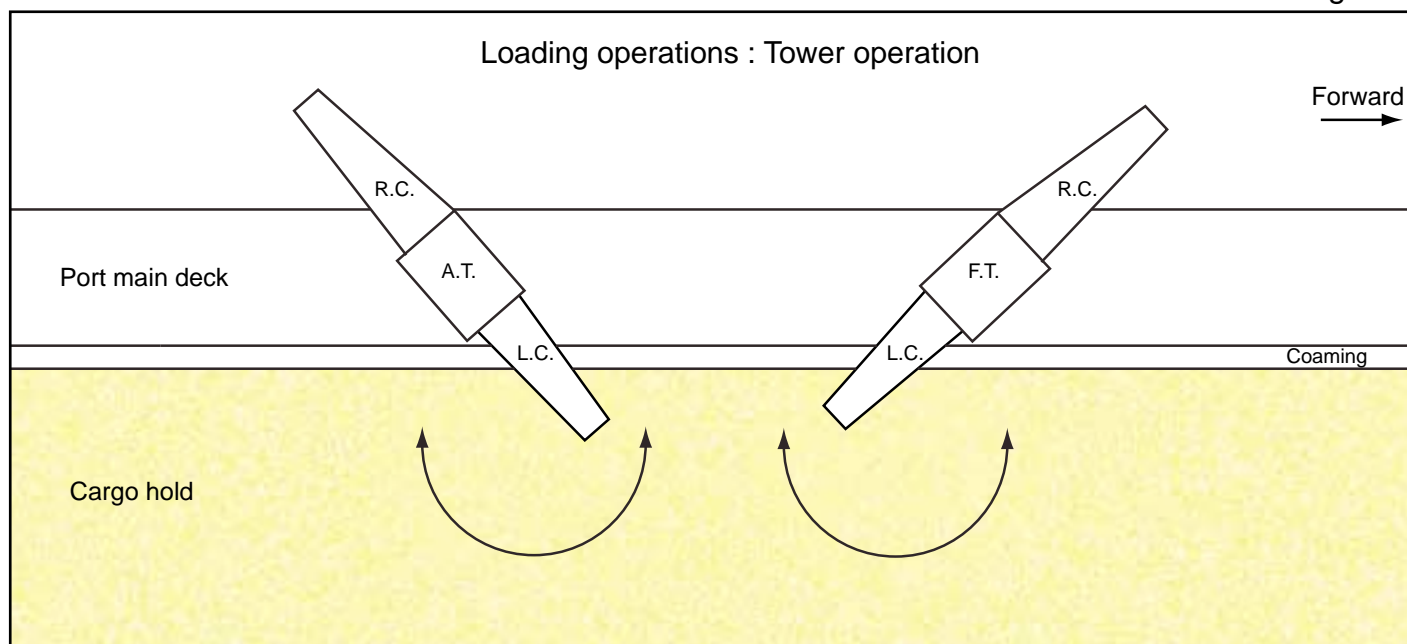

Figure 2b

Figure 3



In the meantime, Sid Mattingley, the bosun, had slackened off the port outhaul wire in the winch room, to give enough slack for the wires to be raised to the hanging-off position. He then went along the port side of the main deck to assist the AB. Sid Mattingley was wearing an orange boilersuit and fluorescent yellow jacket.

At 0925, the second mate contacted Medway Radio to state that the vessel was passing Buoy 32 on the right-hand bend of the river, and then made the appropriate deck log entry. He then used a VHF walkie-talkie on the bridge to acknowledge the request from the deck, with words to the effect, "All right, mate, I'll be with you in a minute". He had assumed it was Sid Mattingley who had contacted the bridge.

The second mate went to the cargo loading console which was situated starboard aft, and turned on the hydraulic power pack for the towers. He looked out of the starboard aft windows which gave a clear view of the cargo hopper, dredge gear and loading towers (**Photograph 2**), and saw the AB standing below the loading chute of the forward tower. He could not see Sid Mattingley and, believing it was Sid Mattingley who had requested the tower movement, assumed that he would be standing in a safe area.

The second mate started to lift the loading chute of the aft tower, also located on the port side, and to swing the tower in an anti-clockwise direction. The loading chute, at the forward end of the tower, swung outboard, and the reject chute, at the aft end of the tower, swung inboard.

The AB heard the hydraulic power pack start, and looked upward, expecting to see the forward tower loading chute rise. He then realised that, instead of the forward one, the aft tower loading chute had been raised. He looked aft just as the aft tower rotated, and saw Sid Mattingley trapped between the aft tower reject chute and hold coaming.

The second mate, realising that Sid Mattingley had been standing on a platform between the aft tower reject chute and the coaming (**Photograph 3**), immediately swung the aft tower in the opposite direction.

Photograph 2



View from bridge loading console

Aft loading tower

Photograph 3

Position of bosun



Enlarged view of crew positions immediately before the accident

The AB saw Sid Mattingley collapse, once the aft tower had released him, and ran to his aid. He found him in serious pain, lying on the platform and holding on to a cable conduit which was attached to the coaming.

The second mate told the master that Sid Mattingley had been injured and then, on the master's orders, went to the main deck to assess the injuries. He returned quickly to the bridge and asked the master to call for medical assistance. Meanwhile, other members of the crew, alerted to the accident, gave assistance to Sid Mattingley in the form of warm clothing and verbal encouragement.

The master contacted the coastguard and Medway Radio. *Arco Adur* then went to Thamesport on the Medway, where an RAF helicopter (Rescue 125) and a lifeboat met her.

Although the paramedics were on board by about 1035, and Sid Mattingley was airlifted to hospital at about 1055, he died as a result of his injuries.

1.4 ENVIRONMENTAL INFORMATION

At the time of the accident the wind was south-east force 3, the sky was clear and bright with good visibility.

1.5 RIVER MEDWAY

Information regarding the movement of ships within the Medway Ports area is managed through the Medway Navigation Service (MNS) call sign 'Medway Radio'.

Pilotage for vessels to or from the River Medway is compulsory for vessels 50 metres and over in length. A compulsory area extends to Rochester, and includes the Swale.

However, pilotage exemption certificates (PECs) are available to certain regular traders on application. These apply to named masters and chief officers on specific vessels.

The master and first mate on *Arco Adur* held current PECs for the river.

1.6 THE VESSEL

(Figure 4 – General Arrangement)

1. General Description

Arco Adur was a trailing suction dredger, designed and equipped to load sand and gravel from licensed dredging grounds, and to transport and discharge the cargo at designated and specially equipped berths in northern Europe.

She had a forward superstructure containing the wheelhouse and crew accommodation, beneath which, within the hull, was an auxiliary machinery space. This was referred to as the forward machinery space and was situated abaft the fore peak water ballast tank. A void space spanned the full width of the hull immediately aft of the forward machinery space. The cargo hopper was situated on the centreline, with wing tanks and voids either side. Walkways, running at tank top level through the voids either side of the hopper, connected the forward void space, via watertight doors, with the main machinery space which was situated aft of the cargo hopper. Aft of the main machinery space, below the poop deck, were the electric winches used during cargo discharge.

Arco Adur used the drag scraper bucket method of discharge. This involved two scraper buckets being pulled back and forth along the length of the hopper. As the electric winches dragged them aft, they dug into the cargo. At the aft end of the hopper the buckets were dragged up a ramp. Large slots at the top of the ramp allowed the cargo to fall through on to a conveyor system. Each bucket had two wires attached, the inhaul and the outhaul. The inhaul wire was connected to a bridle at the aft end of the bucket and passed via a sheave in the funnel housing to the inhaul winch. The outhaul wire was connected to a bridle at the forward end of the bucket. From there, it passed in a loop through a sheave at the forward end of the hopper, and then returned aft to the outhaul winch via another sheave in the funnel housing (**Photographs 4 & 5**).

On the aft mooring deck there were two rotating and luffing boom conveyors for discharging the cargo into receiving hoppers ashore. The cargo capacity was 5100 tonnes and it could be discharged at up to 1800 tonnes per hour.

The dredge suction pipe and the three gantries used to deploy the pipe during loading, were sited on the starboard main deck. The electrically-driven submersible dredge pump was an in-line unit approximately mid-way along the length of the suction pipe. The maximum dredge depth was 42m.

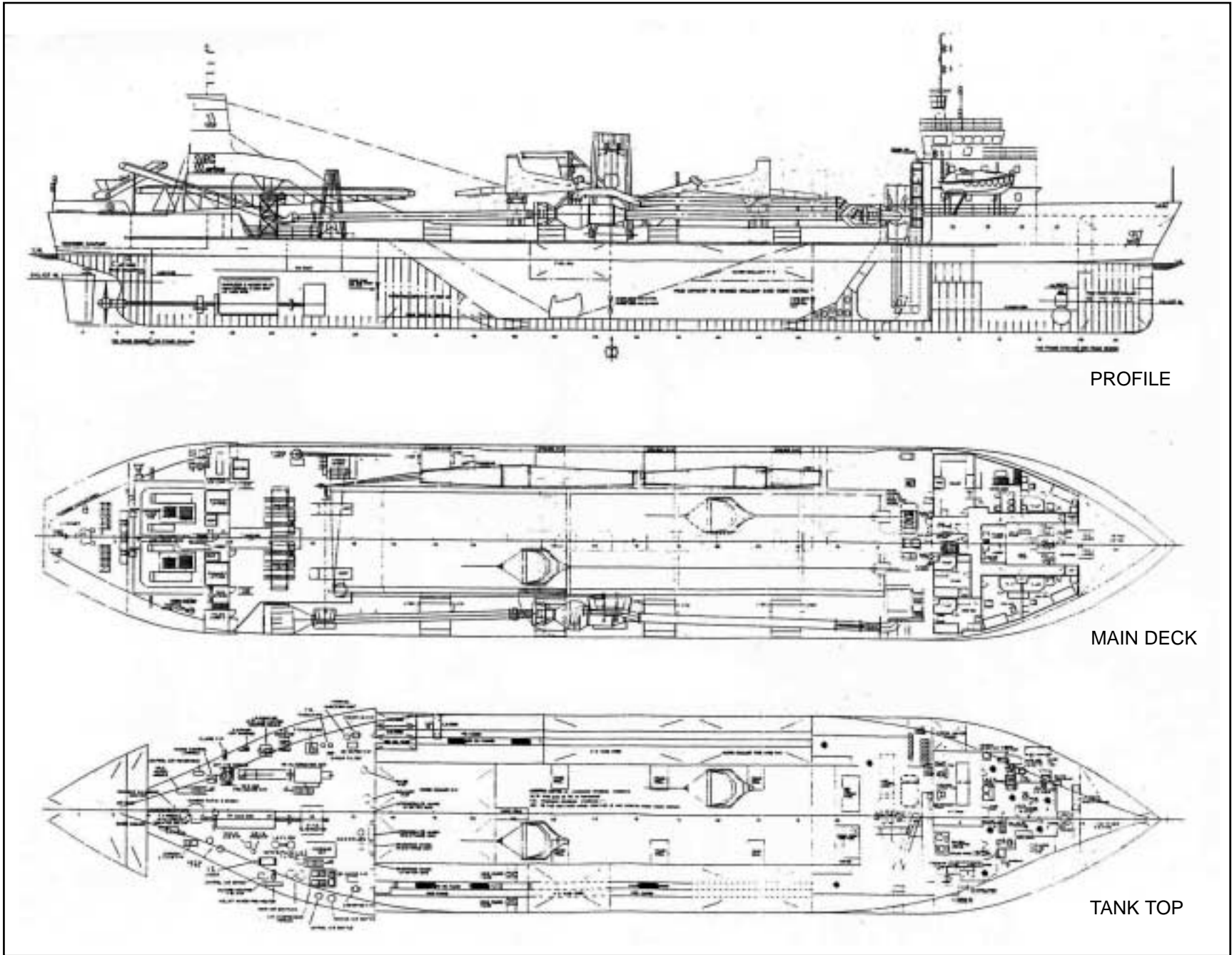

mv *Arco Arun* - General Arrangement
(sister ship of *Arco Adur*)

Figure 4

Port drag scraper bucket

Reject chute

Loading chute

Photograph 4



View across cargo hopper of port bucket arrangement and aft loading tower

Position of cargo loading console
on starboard bridge wing

Forward sheave

Photograph 5



View of sheaves at forward end of hold, from aft loading tower

2. Loading Towers

In January 2000, the two loading towers (or screen grading towers) on the port main deck replaced the original longitudinal centreline loading chute arrangement. This major modification required work to be carried out on the cargo loading pipe, port side main deck, port side void space and bridge.

The towers rotated on fixed structures welded to the deck and were hydraulically operated. Each tower incorporated loading and reject chutes and a grading screen for the cargo. The loading chute could be raised by hydraulic rams to allow an even spread of cargo across the hold. The two loading chutes faced each other when the towers were stowed (**Photograph 6**).

The hydraulic power pack for the towers was protected from the elements in the port void space. Its sole use was for loading tower operation. The controls operating the power pack were located on the starboard side of the bridge at the cargo loading console.

In addition to loading the cargo, the forward tower on *Arco Adur* was used to assist hanging-off the port drag scraper bucket outhaul wire. This method of wire stowage was only carried out on *Arco Adur*, and had gradually been adopted since the towers were fitted. Sid Mattingley had originally proposed this method.

The unwritten procedure was: a strop was connected between a shackle attached to the inboard side of the loading chute and the outhaul wire, the chute was raised and the tower rotated clockwise to bring the outhaul wire above the coaming. The chute was lowered and the wire was manhandled on to a hook which was welded to the coaming (**Photographs 7 - 11**). Another hook was attached to the coaming close to the aft tower reject chute. The aft tower was not needed to hang the wire, as the weight of the wire had been effectively reduced when hung off on the forward hook. This aft section of the wire was simply grappled and manhandled on to the aft hook (**Photographs 12 & 13**).

The outhaul wire was hung off in this way to reduce the wear on the wire when cargo fell on to it from the loading towers and, at the same time, prevented the aft tower loading chute fouling the wire during loading.

Platforms were welded outboard of the coaming at both hook positions to enable the crew to hang the wires without putting themselves at risk by standing on the coaming. The platforms and hooks had been moved several times, at the request of the crew, to find the optimum position along the coaming to facilitate wire stowage (**Photograph 14**). Additionally, the reject chutes had been extended to help rejected cargo clear the deck of the vessel.

Although hydraulic and electrical drawings were supplied to the vessel when the towers were fitted, no constructional drawings were made available. The crew carried out minor maintenance of the towers. Shore contractors carried out major repairs as required.

Photograph 6



View of loading towers in stowed position

Wire stop

Outhaul wire

Photograph 7



View of port outhaul wire being manhandled over forward retaining hook on coaming

Lifting strop

Retaining hook

Photograph 8



View of port outhaul wire positioned on coaming behind forward retaining hook

Photograph 9



View of lifting strop being released from outhaul wire.
Loading chute in stowed position.

Photograph 10



View of port outhaul wire hung off retaining hook

Photograph 11

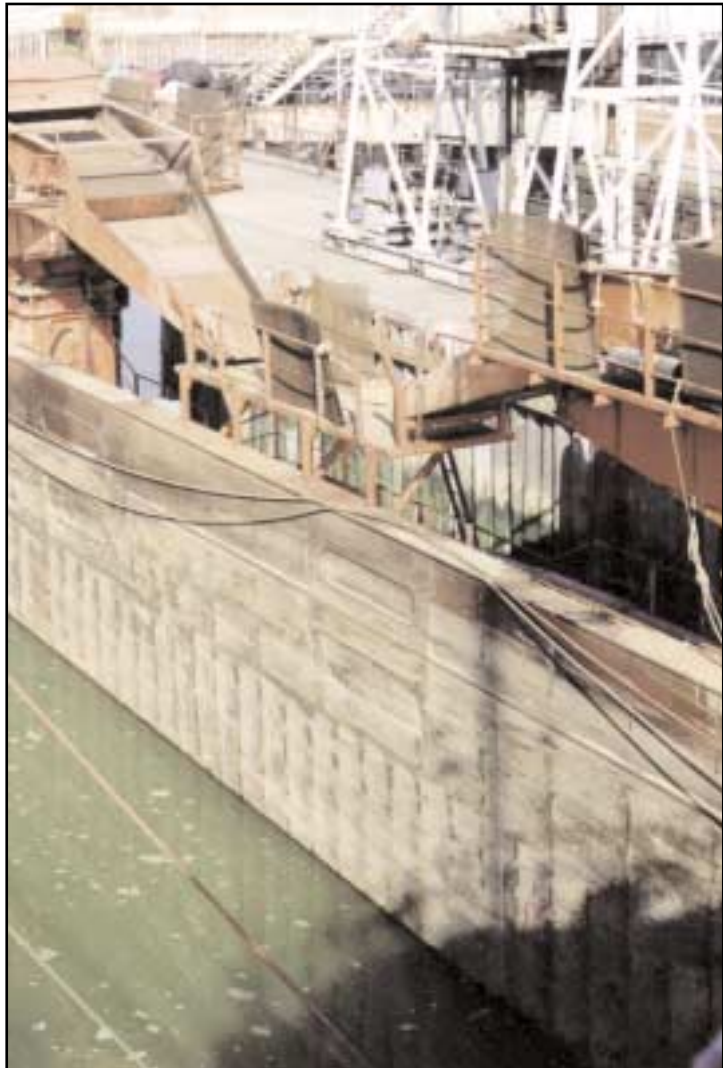

View from bridge loading console of outhaul wire retained behind forward hook

Outhaul wire

Aft tower reject chute

Photograph 12



View of port outhaul wire being manhandled on to aft retaining hook

Photograph 13



View of outhaul wire hung off aft hook



View of aft tower reject chute and platform

3. Loading Tower Controls

The loading console, on the starboard side of the bridge, faced starboard, and during loading operations the controls were normally operated by the left hand of the seated operator as he faced aft. The loading tower controls, incorporated in the loading console, included push-button switches for the hydraulic pumps and a joystick for each tower (**Photograph 15**). The switches did not illuminate, and it could not be determined if the pumps were on or off from the bridge. The normal practice was for the pumps to be started, the towers or loading chutes to be operated, and the pumps to be stopped.

As a protective measure, the joysticks had to be pulled up before they could be moved. Each joystick was labelled for rotation of the tower and raising or lowering of the loading chute. To raise the loading chute on either tower, the joystick was pulled up and then pushed to starboard (outboard), labelled 'up'. It took about 7 seconds to raise the chute fully through 90°.

To rotate the forward tower in an anti-clockwise direction to bring the loading chute over the hold, the forward joystick was pulled up and then pushed in a forward direction, labelled 'slew fwd' (**Photograph 16**).

To rotate the aft tower in a clockwise direction to bring the loading chute over the hold, the aft joystick was pulled up and then pushed in an aft direction, labelled 'slew aft'.

There was no proportional speed control for the towers and they could rotate 90° in about 3 to 5 seconds. This resulted in fast jerky movements as the tower rotated.

Loading tower controls

Starboard

Photograph 15

Forward

Aft



View of cargo loading console, starboard bridge wing

Photograph 16



View of loading tower controls

4. The Wheelhouse

In addition to standard navigation, safety and control equipment, the wheelhouse (**Figure 5**) contained the bucket winch, dredge pipe gantry and dredge pump controls used during loading and discharge. The control stations for these were located aft in the space on port and starboard sides, overlooking the cargo working area.

The navigation and communication instrumentation was housed in consoles which were variously located within the wheelhouse. Two navigational consoles faced forward; one on the port side and the other to starboard. A communications desk was sited on the port side of the space and a navigation workstation on the starboard side. There was a central steering position for both wheel and auto pilot controls. Manoeuvring control stations were on each enclosed wing.

5. Vessel Certification

At the time of the accident, *Arco Adur* was fully certificated to national and international regulations.

1.7 BRIDGE RESOURCE MANAGEMENT

1. Crew

Arco Adur had a crew complement of ten: a master, first mate, second mate, chief engineer, second engineer, third engineer, bosun, seaman, a cook/steward and a trainee deck officer. At the time of the accident, two people were on the bridge.

2. The Bridge Team

The master held a class 2 certificate of competency, with a limited European command endorsement. It had been updated to STCW95 in March 2002. He held a current pilot exemption certificate issued by Medway Ports Authority. After an initial career on deep-sea ships he served on aggregate dredgers, having joined the company preceding Hanson Aggregates Marine in 1976. He had served as master for about 27 years, and had served on *Arco Adur* from January 2000. Following 3 weeks leave he had rejoined the vessel on 19 February 2003, 6 days before the accident.

In addition to general administrative duties, the master carried out loading operations and pilotage work. He also took charge of the bridge watch if special circumstances or dangers dictated.

Figure 5

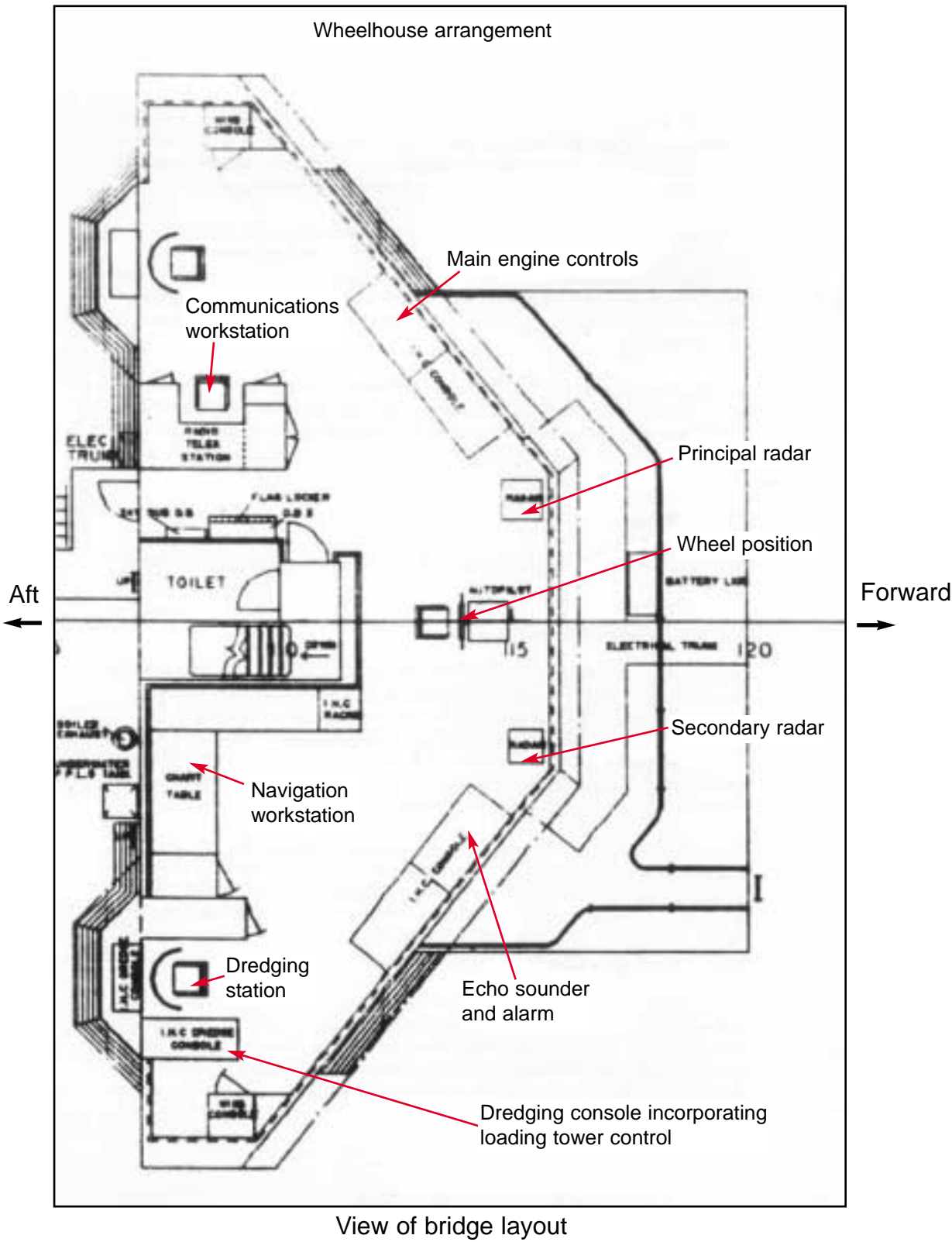

The second mate held a second mate's certificate of competency class 2/1, which he obtained in January 2002. He had followed the NVQ training route, which consisted of experience at sea with the James Fisher fleet, interspersed with periods at Fleetwood college. Before being employed by Hanson Aggregates Marine he had worked on James Fisher coastal tankers and on Ministry of Defence (MOD) mooring vessels.

His employment was organised through an agency, and he had worked for Hanson Aggregates Marine for a total of 51 days up to the accident. This involved two trips on *Arco Arun* totalling 32 days, and a two-week trip on *Arco Adur* between 8 and 22 January 2003. His tour of duty on *Arco Adur* before the accident had also started on 19 February 2003.

3. Working and Watchkeeping Routine

The officers and ratings worked a routine of 3 weeks on duty followed by 3 weeks leave. Two full crews were assigned by the ship manager to *Arco Adur*. With the exception of the trainee officer, the entire crew joined or left the ship on the same day.

The first and second mates alternated bridge watchkeeping, working 8 hours on/8 hours off. This routine did not vary when the vessel was loading, discharging or on passage, except where the vessel was required to have a PEC holder on the bridge. As only the master and first mate held PECs for the River Medway, the first and the second mates had to adjust their watches occasionally to allow for this. This watch alteration had occurred the night before the accident; the second mate going off watch at 2300 on 24 February, and coming on watch at 0500 on the day of the accident.

The bosun and seaman also worked an 8 hours on/8 hours off watchkeeping routine. During daylight hours in good visibility, they generally carried out maintenance around the vessel. At night or in poor visibility, they acted as lookout on the bridge. At the time of the accident, the watchkeeping seaman had been employed hanging-off the outhaul wire on to the port coaming of the cargo hopper. The off-duty bosun had been called at about 0400 on 25 February to assist with the mooring lines on arrival at Eurowharf. After returning to his cabin, he was called again at about 0630. At 0910 he 'let go' aft, before assisting with hanging-off the outhaul wire.

The bosun, Sid Mattingley, had been issued with his AB certificate in 1970. Companies that were eventually acquired by Hanson Aggregates Marine had employed him on board aggregate dredgers since 1978. He had been employed continually on board *Arco Adur* as bosun since 1991. Before the accident, he had joined the vessel on 19 February 2003, with the other crew members.

The usual mooring station for the bosun on *Arco Adur* was aft. After 'letting go' of the aft mooring lines it was not unusual for Sid Mattingley to slacken off the port outhaul wire in the winch room, go to the port main deck, stand on the platform adjacent to the aft tower reject chute and assist with hanging-off the outhaul wire. Once the outhaul wire had been raised, and the weight effectively reduced by the forward coaming hook, it was a straightforward task to grapple each of the two wires of the outhaul wire loop and manually lift and hang them over the aft hook on the coaming.

1.8 THE ISM CODE

The International Maritime Organization (IMO) developed the International Management Code for the Safe Operation of Ships and for Pollution Prevention (the International Safety Management (ISM) Code). Its adoption, in November 1993, was to ensure that safety and environmental awareness was given top priority in the shipping industry. On 1 July 1998, the ISM Code became mandatory under SOLAS for certain types of ships, as part of a phased introduction.

The ISM Code sets out an international standard for the safe management and operation of ships by defining the company's responsibility for safety and pollution prevention and for the implementation of a safety management system (SMS).

The Code states that the safety management objectives of companies should:

- *provide for safe practices in ship operation and a safe working environment;*
- *establish safeguards against all identified risks; and*
- *continuously improve safety management skills of persons ashore and aboard ships...*

The ISM guidelines published by the International Chamber of Shipping / International Shipping Federation (ICS/ISF), which is not mandatory but is recommended reading for Maritime and Coastguard Agency (MCA) surveyors for ISM audits and inspections, gives greater clarity to the requirements in the Code and states, on a safety management system:

The introduction of a safety management system requires a company to develop and implement safety management procedures to ensure that conditions, activities and tasks, both ashore and afloat, affecting safety and environmental protection are planned, organised, executed and checked in accordance with legislative and company requirements...

On the advantages of establishing a safety management system, the ICS/ISF guidelines state that:

A structured safety management system enables a company to focus on the enhancement of safe practices in ship operations and in emergency preparedness. A company that succeeds in developing and implementing an appropriate safety management system should therefore expect to experience a reduction in incidents which may cause harm to people...

An important feature of the Code is that of the appointment of a designated person (DP). This shore-based person has access to the highest level of management and should have the knowledge, authority and responsibility to monitor the safety and pollution prevention aspects of the company's operations **(Figure 6: reporting lines)**.

After a successful audit, the shore-side operation will be issued with a Document of Compliance (DOC), while the shipboard operation is issued with a Safety Management Certificate (SMC). The DOC is specific to ship type e.g. dredgers, and is valid for a maximum of 5 years subject to annual verification. An SMC is valid for a maximum of 5 years, and will be subject to one intermediate verification between the second and third anniversaries. In the UK, both these documents are issued and audited by the MCA.

In comparison to the SMC, the Domestic Passenger Ships' Safety Management Code (DSSMC), a simplified version of the ISM Code for coastal passenger vessels, requires an audit to be carried out, not only yearly, in conjunction with the vessel's Passenger Certificate, but, additionally, mid-term.

Since 1 July 2002, all ships subject to the Safety of Life at Sea (SOLAS) Convention were required to meet the provisions of the ISM Code.

1.9 ISM IMPLEMENTATION

The operator of *Arco Adur*, Hanson Aggregates Marine Ltd, implemented International Safety Management (ISM) certification on its vessels ahead of the required 1 July 2002 implementation date for 'other cargo ships'.

On 20 November 2000, the MCA issued the company with a DOC. This was valid until 16 November 2005, with the first and second annual verifications occurring on 5 February 2002 and 21 November 2002. This document certified that the Safety Management System of the company had been audited, and that it complied with the ISM Code.

On 17 July 2001, the MCA had issued *Arco Adur* with a Safety Management Certificate (SMC). This was valid until 3 May 2006, subject to periodical verification and the validity of the Document of Compliance.

SAFETY MANAGEMENT MANUAL

Section B

**SAFETY MANAGEMENT SYSTEM
REPORTING/LINES OF RESPONSIBILITY**

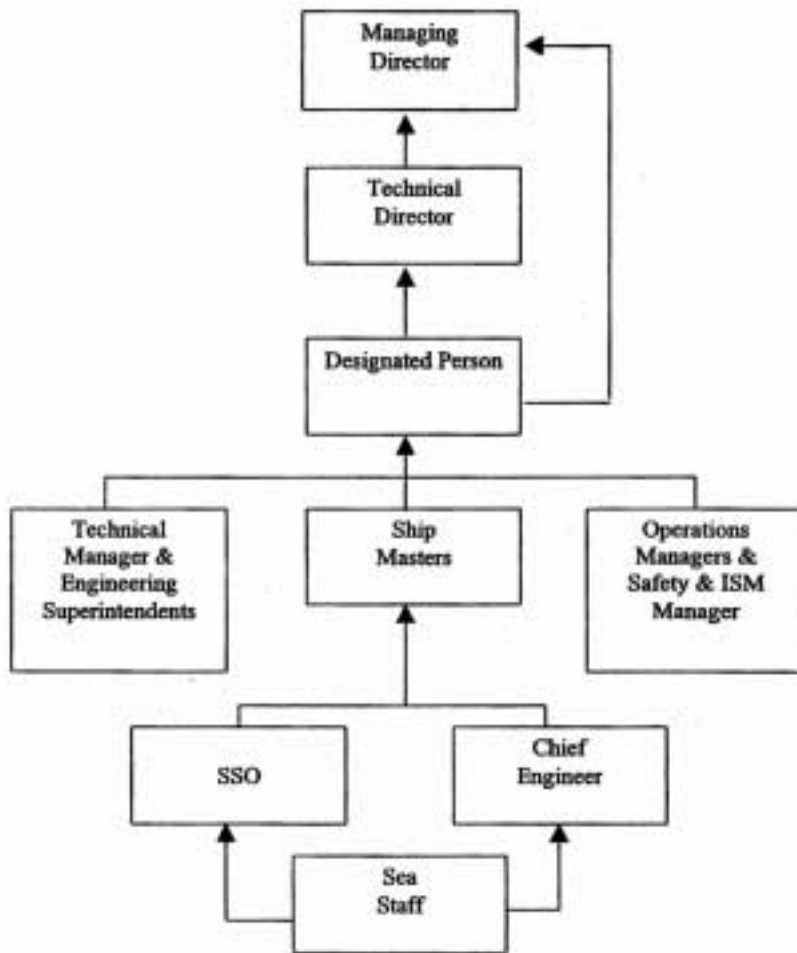

GPSW/ISM/0006/SAFETY.PPT



Issue/Amendment Approval by:

B DENNETT MANAGING DIRECTOR

B.2

Dated: Oct 2001

The Safety Management System was generic in nature across the fleet, no specific procedures were produced for regular deck operations and it gave an overview of these operations without giving any detail as to how they were carried out.

Section 7 of the ISM Code, 'Development of Plans for Shipboard Operations', states:

The company should establish procedures for the preparation of plans and instructions for key shipboard operations concerning the safety of the ship and the prevention of pollution. The various tasks involved should be defined and assigned to qualified personnel.

To address problems which had been encountered since the introduction of the Code, amendments were made which came into force on 1 July 2002. In Section 7, this involved the inclusion of 'checklists'. These became mandatory for particular shipboard operations, such as vessel pre-departure/arrival, bunkering, cargo operations etc, and as deemed necessary for other operations. A revised Marine Guidance Notice on the amended ISM Code has yet to be circulated by the MCA.

The recommendations in the International Chamber of Shipping / International Shipping Federation guidelines of the ISM Code, are that companies should identify key shipboard operations and issue instructions on the manner in which these operations are to be performed.

1.9.1 Audit structure

The MCA carries out ISM audits and Safety Equipment Certificate (SEC) surveys. All other legally required surveys are delegated to the vessel's classification society.

The MCA carries out audits from its headquarters in Southampton and the regional marine offices. The headquarters dealt primarily with the Document of Compliance audit, while the marine offices undertook Safety Management Certificate audits.

The MCA Instructions for the Guidance of Surveyors for the ISM Code, Chapter 1.9: the Audit for Compliance, states:

The audits will be carried out within the scope of the "Guidelines on Implementation of the ISM Code by Administrations", IMO Resolution A.788 (19). In addition, the International Chamber of Shipping in association with the International Shipping Federation has produced "Guidelines on the Application of the IMO International Safety Management (ISM) Code". It is recommended that surveyors become familiar with both these publications as they establish underlying principles for verifying that a shipping Company's SMS complies with the ISM Code.

An ISM audit is similar in many ways to a port state control (PSC) inspection. The surveyor is not expected, in the one day that he has on board, to be able to examine everything. He is expected to examine samples of the way the ISM system on board is working. The shipping company has a duty to ensure that its ISM system is working properly, and should not rely on the MCA surveyor to pick up all deficiencies.

The surveyor carrying out the initial audit had been sufficiently trained in the auditing process. This involved a 5-day ISM auditors' course, operated by the MCA, carrying out several audits alongside other more experienced surveyors, and, finally, being observed while carrying out an audit. However, as much more time talking to the crew is required for the audit, a different mindset is required for auditing, in comparison to surveying for port state control (PSC) purposes.

The audit carried out on *Arco Adur* in May 2001 was the first, or initial, audit for the vessel. The audit, carried out during one day, consisted of reviewing the ISM system on board, interviewing a selection of the crew and inspecting the vessel. During the initial audit, the surveyor tried to sample all sections of the ISM Code and to pick particular items for closer inspection. In this case, the surveyor chose the bunkering operation as being an irregular shipboard operation. Six members of the crew were interviewed to ensure that they were familiar with the Safety Management System (SMS) on board, and their job requirements and responsibilities. They were all experienced aggregate dredger crew and no concerns were raised.

The initial audit is an overview of all aspects of the operation of the ISM Code and, in view of time constraints, it cannot go into detail on every section of the Code. Once the SMC has been issued, the surveyor will be able to look in greater detail at several areas of the Code at the subsequent intermediate and renewal audits, to ensure compliance. However, as the intermediate audit could be up to 3 years later, any structural deficiencies in the Safety Management System, not picked up during the initial audit, might continue to have repercussions during that time.

1.9.2 Internal audits

The company should conduct internal audits of its ships at regular periods to enable a reasonable assessment of the effectiveness of the SMS on board. These internal audits should then be produced during the renewal verification to allow the surveyor to have a clear picture of the company's ISM system.

Two internal audits were carried out on *Arco Adur* between the SMC being issued and the accident. Like the MCA initial audit, these audits did not find the ship's procedures, regarding operation of the loading towers, deficient.

1.10 SAFE WORKING PRACTICES

The Code of Safe Working Practices for Merchant Seamen (COSWP), which is concerned with improving health and safety on ships, provides guidance on safe working practices. With respect to the ISM Code objective of establishing safeguards against all identified risks, the COSWP is intended to assist companies in identifying those risks and establishing safe practices.

The company's Risk Assessment Book, Section 2 Health and Safety at Work, Part b, contained a section on "Equipment Training" (COSWP 7.5.8/9):

The risk has been recognised and has been covered by induction training, ship/job change training also formalise Crane Operators Training. The requirements for training are covered under the Safety Management Manual procedures 8.2 and – Onboard Crane Training and Operations 8.5.

<i>Risk Assessment:-</i>	<i>Accident</i>	<i>-</i>	<i>Possible</i>
	<i>Harm</i>	<i>-</i>	<i>Moderate</i>
	<i>Risk</i>	<i>-</i>	<i>Moderate</i>

It is recommended that because the rules cover the current risk no further action need be taken until new equipment or further ships become operational.

Target Date: Completed

Date: 04.00

New equipment, in the form of the loading towers, had been added since this document was introduced, but no equipment training for them had been developed.

The Code of Safe Working Practices for Merchant Seamen (COSWP) Section 7.5.9 states:

Training should consist of theoretical instruction enabling the trainee to appreciate the factors affecting the safe operation of the lifting plant, and supervised practical work with the appropriate plant etc. Employers may issue certificates to personnel who have successfully completed training, specifying the type of appliance on which the test was carried out.

Suitable instruction was given for the operation of the shipboard crane, but as the forward loading tower was not viewed or certificated as lifting equipment, no such training for its operation was given.

In the company's Safety Management Manual, Section C, Procedure for Risk Assessment:

A copy of the ships completed risk assessment will be lodged in their individual ships' Risk Assessment booklet. The ships risk assessment should be reviewed by sea staff at the completion of the ships yearly repair stop if there has been a change of operations or equipment, also at the Masters Review.

This document was dated May 2000. The loading towers were installed on *Arco Adur* in January 2000, and the SMC was issued in July 2001. No shipboard risk assessments relating to the loading towers were introduced. It was foreseeable that the loading towers would require maintenance, or that other work, such as screen changes and hanging-off the port outhaul wire, would occur.

The operation of hanging-off the port outhaul wire involved crew members standing between the loading tower chutes and the cargo hold coaming. It is, therefore, reasonable to expect that the company would have procedures in place to cover all aspects of this task. Those procedures, and any special precautions to be observed, should have been available in the ship's safety manual.

Members of the deck crew had recognised the risk of the aft loading tower rotating anti-clockwise while a crew member stood on the aft platform. This was an accepted risk as the tower was not expected to be operated while a crew member stood on the platform, and was not considered to be a high enough risk to require raising at a safety meeting.

The deck crew was also aware that the area forward of the forward loading tower was considered unsafe. When the tower was rotated clockwise, the reject chute at the forward end moved inboard over the port coaming, potentially trapping anyone who had placed themselves between the chute and the coaming. However, the area was difficult to access and there was no need for any crew member to be there.

The company's Safety Management Manual, Section C 'Procedure for Risk Assessment' states:

1. *The risk assessment of the Company's fleet is carried out by grouping ships into vessel class as far as possible, with the differences being subject to separate assessment as follows:-*

i) *The 'A' Class - No differences*

The method of hanging-off the outhaul wire was the same on three of the four 'A' Class vessels, however, *Arco Adur* was different, because it used the forward cargo loading tower. This was known and accepted by Hanson Aggregates Marine, but no separate risk assessment was carried out on *Arco Adur*.

Also in the company's Risk Assessment Book, Permit to Work – 'Recommended Requirements (Bucket Discharge)', there was no specific item for hanging-off the outhaul wire or operating the loading towers (**Figure 7**). However, the loading towers are included on the Permit to Work form for the 'bucket wheel discharge' vessels in the company. The permit, in this case, is for isolating the power to the towers prior to work commencing. Additionally, it states that a *reduction of requirements [are] to be assessed for routine work*. Hanging-off the port outhaul wire was done after every discharge and, therefore, could be classed as routine.

Figure 7

Permit to Work - Recommended Requirements

OP597DC/PERMIT.DOC

(Bucket Discharge)

Activity	Yes/No	Permit to Work	Isolation	Control	Other	Other	Other	Other
Work on radar aerial(s)	Yes	OOW	Radar rotate	Radar transmit				Fuse to be removed.
Work on radio aerial(s)	Yes	OOW		Radio transmit				Fuse to be removed.
Work on main mast and funnel		OOW & Duty Eng.	Main engine start	T & S Class Radio transmit Radar transmit	T & S Class Ship's Whistle			Fuses to be removed.
Work on hold/topper (Dead Cargo)	*Yes	OOW & Duty Eng.	Bridge bucket controls	Local bucket controls	Duct door pump	(Work areas to be posted)	(Walk boards to be used, harness worn.)	Not required for changing bucket or slack inhaul/ outhaul wires.
Work on conveyors	*Yes	OOW & Duty Eng.	Conveyor starts	*Local conveyor controls				* Conveyor controls to be isolated. The person working on the conveyors may, if given prior permission, use local controls.
Work on gantries or Pipe	*Yes	OOW & Duty Eng.	Main pipe controls	*Local wash controls				*Controls to be isolated. The person working on the pipe/gantry may, if given prior permission, use local controls.
Work over the side	*Yes	OOW & Duty Eng.	Main engine clutch	Bow thrust motor	Rudder steering motor	Inform Port Control, hoist signal		*Assessment of how work is to be carried out for need to have full released or no permit procedure.
Work on super-structure & Sternmast		OOW & Duty Eng.	'A' Class Radio transmit Radar transmit					
Hot Work	Yes	OOW & Duty Eng.				As per permit form and fire entry	As per contractors instructions	
Entry into enclosed or confined spaces	Yes	OOW & Exec. Eng. Contractor.				As per permit form and Company tests.	As per contractors instructions	
Divers	Yes	OOW & Duty Eng.	Main engine clutch	Bow thrust motor	Rudder steering motor	Confirm approved divers	Inform port control hoist signal	Isolate Echo Sounder.
Large contract works	*Yes	OOW & Exec/Elec Eng. Contractor				See permit to work for instructions	Inform crew and other contractors	*Risk to be assessed allowing for - fire, flood, explosion, overhead work & unsafe areas
Work on mechanical & electrical machinery	*Yes	OOW & Duty Eng.				See permit to work for instructions		*Prior permission by H.O.D. is to be obtained if reduction of requirements is needed.

1.11 INDUCTION PROCESS

Section 6 of the ISM Code includes:

6.3 *The Company should establish procedures to ensure that new personnel and personnel transferred to new assignments related to safety and protection of the environment are given proper familiarisation with their duties. Instructions which are essential to be provided prior to sailing should be identified, documented and given.*

When the second mate first joined the company, working on board *Arco Arun*, sister ship to *Arco Adur*, he was required to go through an induction process. This involved doubling up with another deck officer for a minimum of 3 days, in addition to the master completing a checklist (sea staff induction form) to ensure that all aspects of the second mate's induction were completed. An explanatory form (induction familiarisation for seagoing employees) to assist the master was included in the induction process (**Figure 8**).

Figure 8

Induction familiarisation for seagoing employees

As a ship's master you will be responsible for the initiation and monitoring of a new crew member into the company and/or new ship. This induction check list has been prepared for your guidance. The list covers general administration and all aspects of shipboard familiarisation. The objectives are as follows:-

1. To integrate the new crew member into the workforce and systems of work as quickly as possible.
2. To secure their own safety and that of others.
3. To avoid crew member "picking things up as he/she goes along" - sometimes incorrectly.

The emphasis of the induction is on safety. The induction activities are grouped and numbered. The groups have time limits, it does not mean activities cannot be completed earlier than the required group time limit and the numbering does not indicate the order in which activities need to be done. Naturally, many aspects of the form will be delegated to the ship's safety officer and other crew members of the crew as appropriate. As with all training, it is important to check that the induction process has been effective. It is therefore essential that the member's understanding is checked, particularly on important safety aspects.

On completion of the various subjects covered tick (✓) each item in the appropriate box and return the form duly signed to the company's personnel manager no later than 28 days after the date the crew member joins your ship.

This form contains both company and statutory requirements

On his second trip on *Arco Arun*, the departing second mate gave him no formal handover, but he did receive handover notes.

Although the equipment on *Arco Arun* was the same as on *Arco Adur*, the hanging-off of the drag scraper wire on the former, was carried out manually, without the assistance of the forward loading tower.

When the second mate first joined *Arco Adur*, on 8 January 2003, he was not given a formal handover, not 'doubled up' with anyone, and received no handover notes. This also occurred on his subsequent tour of duty. However, the second mate did complete an induction form on his first tour of duty on *Arco Adur*, which was signed off on 26 January 2003 (**Figure 9**). The master did not think it necessary that the second mate was 'doubled up' as he considered the second mate competent and experienced.

Section 6 of the ISM Code also states:

6.5 The Company should establish and maintain procedures for identifying any training which may be required in support of the SMS and ensure that such training is provided for all personnel concerned.

The second mate had received training from the master on the cargo loading operation using the loading towers, although the master normally carried out all loading operations. It was not unusual for the two deck officers to get the loading equipment ready before the master came to the bridge. As cargo loading occurred virtually on a daily basis, the second mate was well versed in the operation of the towers for this purpose.

However, the second mate had operated the towers only once before, to assist in hanging-off the port outhaul wire, and that was during his first trip on *Arco Adur*. On that occasion, he had been asked to operate the tower, but mistakenly believed that both towers were used to stow the outhaul wire. He had, therefore, operated both towers, although only the forward tower was needed.

The second mate had received no formal training on the operation of the towers for outhaul wire stowage, and no one had informed him that the aft tower was not required.

Section 6 of the ISM Code further states:

6.6 The Company should establish procedures by which the ship's personnel receive relevant information on the SMS in a working language or languages understood by them.

The International Chamber of Shipping / International Shipping Federation guidelines are that procedures and instructions for operations carried out within the SMS should be clear, and written in a simplified manner, to limit the opportunity for misunderstandings to occur.

Hanson Aggregates Marine did not have written procedures for the operation of the cargo loading towers for either normal loading operations or for hanging-off the outhaul wire.

Figure 9

Hanson							
Officer's name <u>ADUR</u>		Rank <u>2/MATE</u>		ICD <u>ADUR</u>		Date joined ship <u>8.1.03</u>	
Previous co ships	✓	Previous co ships	✓	Previous co ships	✓	Previous co ships	✓
<input type="checkbox"/>		Beck	<input type="checkbox"/>	Dijk	<input type="checkbox"/>	Humber	<input type="checkbox"/>
<input checked="" type="checkbox"/>		Bourne	<input type="checkbox"/>	Severn	<input type="checkbox"/>		<input type="checkbox"/>
<input type="checkbox"/>		Thames	<input type="checkbox"/>	Dart	<input type="checkbox"/>		<input type="checkbox"/>
<input type="checkbox"/>		Tyne	<input type="checkbox"/>	Dee	<input type="checkbox"/>		<input type="checkbox"/>
In tick shaded areas to be satisfaction		1st co ship	Other co ships 1st joining	Please tick shaded areas to indicate satisfaction		1st co ship	Other co ships 1st joining
Upon first arrival on board				10	Show location and operation of weather and watertight openings		<input checked="" type="checkbox"/>
Check validity of certificate of competency							<input checked="" type="checkbox"/>
Check validity of medical certificate							<input checked="" type="checkbox"/>
Confirm certificates are originals							<input checked="" type="checkbox"/>
Sign articles of agreement							<input checked="" type="checkbox"/>
Explain emergency signals							<input checked="" type="checkbox"/>
Show emergency station							<input checked="" type="checkbox"/>
Show location of life saving equipment							<input checked="" type="checkbox"/>
Show location of emergency stations							<input checked="" type="checkbox"/>
Explain what to do if fire or smoke is discovered							<input checked="" type="checkbox"/>
Show location of life jacket(s)							<input checked="" type="checkbox"/>
Employer to correctly don a life jacket							<input checked="" type="checkbox"/>
Explain duties and safety responsibilities							<input checked="" type="checkbox"/>
Confirm understanding of watchkeeping duties							<input checked="" type="checkbox"/>
Complete within 48 hours of joining ship				C Complete within 7 days of joining ship			
Explain reason for induction procedure							<input checked="" type="checkbox"/>
Confirm name and responsibilities of SSO							<input checked="" type="checkbox"/>
Explain location and use of rules/company regulations							<input checked="" type="checkbox"/>
Explain emergency procedures							<input checked="" type="checkbox"/>
Show location and use of machinery lock-outs and stop buttons							<input checked="" type="checkbox"/>
Explain machinery/conveyor hazards							<input checked="" type="checkbox"/>
Explain hazards related to walking on cargo							<input checked="" type="checkbox"/>
Show location of fire-fighting equipment							<input checked="" type="checkbox"/>
Confirm issue of protective clothing and related regulations							<input checked="" type="checkbox"/>
				1	Explain shore leave regulations		<input checked="" type="checkbox"/>
				2	Explain disciplinary and grievance regulations		<input checked="" type="checkbox"/>
				3	Explain performance evaluation system		<input checked="" type="checkbox"/>
				4	Explain travel expenses system		<input checked="" type="checkbox"/>
				5	Explain use of cellphone		<input checked="" type="checkbox"/>
				6	Explain sea staff cash advances		<input checked="" type="checkbox"/>
				7	Explain crew travel arrangements		<input checked="" type="checkbox"/>
				8	Explain video training library		<input checked="" type="checkbox"/>
				9	Explain training reference library		<input checked="" type="checkbox"/>
				D Complete within 21 days			
				1	Take part in an emergency procedure (fire and/or load)		<input checked="" type="checkbox"/>
				2	Don an immersion suit		<input checked="" type="checkbox"/>
				3	Don a TPA whilst wearing a life jacket		<input checked="" type="checkbox"/>
				4	Demonstrate knowledge of portable fire extinguishers		<input checked="" type="checkbox"/>
				5	Demonstrate how to open and close watertight and weatherlight openings		<input checked="" type="checkbox"/>
				6	Confirm relevant documents and manuals have been read and signed for as appropriate		<input checked="" type="checkbox"/>
I, that _____ has satisfactorily completed his/her induction as detailed above and is considered competent to safely carry out his/her duties on board as assigned.							
Signature				Signature		Date <u>26.1.03</u>	
Signature				Signature		Date <u>26.1.03</u>	
Signature				Signature		Date <u>26.1.03</u>	
Top copy to office - Bottom copy ROB							
LPHS/INDUCTION				Published by Hanson's Ltd (2002) and 2003 4-880 401200 1/02			

1.12 ALCOHOL AND DRUGS

No toxicological testing was carried out after the accident. However, alcohol is not carried on *Arco Adur* and there is no indication that drugs, either illicit or medicinal, played any part in the accident.

1.13 PREVIOUS INCIDENT

A very similar incident occurred on board *Arco Adur* in 2001. Fortunately, on that occasion there were no injuries. A crew member had been standing on a platform between the tower reject chute and the coaming. The loading chute of the tower was raised from the crutch, before the tower was rotated. The person operating the tower saw the crew member by the reject chute in time, and stopped any further movement of the tower.

Only the two persons involved were party to this incident, and it was not reported to the master, nor was it raised at a safety meeting, even though there was a hazardous occurrence reporting system in place. The crewman on the platform had assumed that the other crew members were aware of the hazard posed by the position of the platform in relation to the chute and coaming and, therefore, did not consider it worthy of reporting. He had recognised the danger of the aft tower rotating while a crew member was on the platform soon after he joined the vessel. The officer on the bridge did not report it on the assumption that it was known about and no purpose would be served.

These crew members had been involved in onboard vessel safety meetings on several occasions, but were not aware of any discussions on the safe operation of the loading towers except with reference to the hazards posed when the grading screens were changed.

Section 9 of the ISM Code 'Reports and analysis of non-conformities, accidents and hazardous occurrences' states:

9.1 *The SMS should include procedures ensuring that non-conformities, accidents and hazardous situations are reported to the Company, investigated and analysed with the objective of improving safety and pollution prevention.*

9.2 *The Company should establish procedures for the implementation of corrective action.*

As this incident was not reported, it could not be acted upon by the company and, therefore, could not be used to initiate procedures for the safe operation of the loading towers.

In the company's Safety Management Manual, Procedures for Masters' Review of Health, Safety and Pollution Prevention Onboard:

The Health and Safety Meeting is to be held quarterly using alternate crews. All sea staff are considered members of the ships' Health and Safety Committee. The meeting is to be planned to allow the maximum amount of crew to attend. The master is to make the crew aware that safety and pollution prevention are of primary importance and that a positive input for the crew at the meetings is expected.

The hazard posed to crew members, when standing on the aft platform, was not a discussion item at any of the safety meetings on board *Arco Adur*.

SECTION 2 - ANALYSIS

2.1 AIM

The purpose of the analysis is to determine the contributory causes and circumstances of the accident as a basis for making recommendations to prevent similar accidents occurring in the future.

2.2 INDUCTION OF NEW STAFF

Familiarisation with safety management system (SMS) related duties is essential for new personnel, so that they may become aware of their responsibilities, and also to maintain the continuity and effective performance levels of the SMS.

The ships' senior officers were expected to guide a new member of the crew through the induction process without reference to any written procedures. It was highly likely that varying levels and content of operational information were provided on different ships. There was no guidance on the minimum information to be provided.

The induction procedure should allow sufficient time for a crew member to become acquainted with specific equipment that he or she will operate. *Arco Adur's* second mate had been acquainted with the loading tower controls when used for loading, but he had not been given instructions which would have allowed him to operate the forward tower safely when it was used to assist with the outhaul wire hanging-off operation.

New members of the crew, officers and ratings, received an induction based upon a checklist. Although the checklist might have been adequate as an aide memoire for long-serving members of the crew, it was not detailed enough for someone either unused to aggregate dredgers or new to the vessel. The checklist was very generalised and there were no associated procedures for operation of equipment or detailing of hazards. The ship's staff was relied upon to supply all the relevant information to the new crew member. The level of knowledge required by a rating and an officer is different; the checklist should have been tailored accordingly.

The induction familiarisation form used to assist the master with the induction process highlights the problem (**Figure 8 - objective 3**) of a new crew member '*picking things up as he/she goes along – sometimes incorrectly*'. The second mate had not been taken through the procedure for operating the towers to stow the outhaul wire, and had 'picked up' what he believed was the correct method.

2.2.1 Handover

The failure to supply the second mate with either a verbal or written handover on joining *Arco Adur* is contrary to the ICS/ISF guidelines (referring to Section 6 of the ISM Code) which specify a period of 'handover' as one of the methods of familiarisation for new crew members.

2.2.2 Guidelines

The International Chamber of Shipping / International Shipping Federation guidance includes the need for arrangements to be in place to monitor the operational competence of crew when undertaking critical shipboard operations. Hanson Aggregates Marine had the ICS/ISF guidelines as a reference, but it is unclear why the guidance offered was not utilised.

Hanson Aggregates Marine had no formal procedure to identify areas of crew training that were deficient or non-existent. As there was no detailed standard of training across the fleet, deficiencies in the training process could not be highlighted.

However, crew members should be pro-active in their training requirements and let senior ship's staff or the company management know if they believe their training is deficient.

2.3 OPERATION OF HAZARDOUS EQUIPMENT

2.3.1 Equipment training

Aggregate dredgers are specialised vessels which use large heavy plant designed to operate under extremely arduous conditions. The crews who operate both the vessel and equipment on board need to be fully conversant with the equipment they are using, and standardised operating procedures should be employed.

The master trained the second officer in the operation of the loading towers for loading operations, but not for the outhaul wire stowage operation. The expectation from the ship's crew and company was that he would 'pick it up' on the job. This, though, went against company induction familiarisation training.

It is possible, that by operating both loading towers on a regular basis, in readiness for loading, the idea that both towers were also used for hanging-off the outhaul wire was strengthened in the second mate's mind.

The second mate was given no guidance or rebuke when he wrongly operated both towers during his first tour of duty on *Arco Adur*. He wrongly assumed that this method of operation was the correct one for hanging-off the outhaul wire.

2.3.2 Usual procedure

After 'letting go' the aft mooring lines it was not unusual for Sid Mattingley to slacken off the port outhaul wire in the winch room, go to the port main deck and stand on the platform adjacent to the aft tower reject chute to assist with the wire stowage. Either he, or the AB, could have carried out this preparation before hanging-off the outhaul wire. This was the usual procedure, and he knew the operation well. He did not expect the aft loading tower to be operated. Once the AB at the forward tower had hooked the outhaul wires over the retaining hook on the coaming, it was a straightforward job for the bosun to capture the wires with a grapple and haul them manually up on to the coaming. Although one crew member could secure each wire in turn, it was usual for the second crew member to assist. The aft platform was also a good observation point from where the progress of the crew member at the forward tower could be seen.

2.3.3 Hazard awareness

The deck crew were aware of the hazard posed by the rotation of the forward tower when hanging-off the outhaul wire. However, as usually only two members of the crew were on deck during the hanging-off operation, the likelihood of one of them standing between the forward tower reject chute and the port coaming was negligible, as there was no reason to stand there when the tower was operated. The possibility that the aft tower might be operated in error and, thereby, trap a crew member between its reject chute and the coaming had not been raised at any safety meetings. Although the deck crew realised the hazard if the aft tower was rotated while someone was standing on the aft platform, it was considered too simple a mistake to make. Raising this hazard as an issue at a safety meeting was considered to be akin to questioning the professionalism of those on board.

2.3.4 Ergonomics

Due to the orientation of the dredge control panel in relation to the platform adjacent to the aft tower reject chute, it is probable that Sid Mattingley stepped on to the platform at the same time as the second mate looked down to the tower controls to rotate the aft tower. As the bosun was wearing a fluorescent yellow jacket, it is unlikely he would not have been spotted had he already been on the platform when the second mate looked out of the window.

2.3.5 Correct tower operation

The direction of rotation of the aft loading tower, operated by the second mate at the time of the accident, was consistent with his belief that the aft tower was also used for outhaul wire stowage. By rotating the aft tower anti-clockwise the loading chute, at the forward end of the tower, swung outboard which would have brought the outhaul wire over the coaming, had it been attached to the loading chute. It would have been difficult to see whether a strop was attached

between the aft loading tower loading chute and the outhaul wire from the bridge loading console, although the raising of the port outhaul wire might have been seen. Had the second mate been adequately trained in the full use of the forward loading tower, this accident might not have occurred.

2.3.6 Good communication

The radio communications before the accident neither identified which tower was to be operated, nor who was speaking. Shortcuts taken in communications are more likely to lead to accidents when new staff are involved, or an unplanned change in the routine is carried out. The request from the deck, to the effect, “Can we swing the tower please?” might easily have been understood by a long-serving regular crew member, but was not specific enough for inexperienced crew members. Additionally, the reply, to the effect, “All right mate, I’ll be with you in a minute” was also not consistent with good communication practice; neither confirming that the request was fully understood nor which tower was to be operated. As the two crew members did not identify themselves, the second mate believed he was talking to the bosun. This resulted in the assumption that the bosun was standing in a safe area.

When operating hazardous equipment, it is essential that communication is perfectly clear and misunderstandings cannot occur. One of the advantages of portable communication equipment is that it can be used to ascertain quickly if all involved crew members are in a safe position before hazardous equipment is operated. This was not done before this accident.

2.3.7 Hazard warning

The loading towers did not have warning indicators, like those fitted to the cargo discharge gear, to warn those on deck that the towers were about to move. However, this alone would not have prevented the accident, as the deck crew were expecting the forward tower to move. The use of local emergency stops for each tower might have helped prevent this accident.

2.3.8 Implementing new operational practices

The crew members on board *Arco Adur* instigated the method of using the forward loading tower for hanging-off the outhaul wire. There appears to have been no discussion on the safety implications of the method, either ashore or on board. Introducing new operational practices, particularly those involving moving equipment, without any form of risk assessment, increases the possibility of an accident and is contrary to the aims of the ISM Code. Had a risk assessment been carried out, it might have been realised that the forward loading tower reject chute was being used as a lifting device for which it was not designed or tested, in addition to the hazard of crew members standing between the loading tower chutes and the coaming.

2.4 ISM

To achieve a sense of ownership, and thus greater involvement by the shipboard staff, their direct input in the formation and implementation of the SMS is required. The International Chamber of Shipping / International Shipping Federation guidelines on the ISM Code, recommend the involvement of ship and shore-based staff in the production of the SMS. It is far easier to have ship's staff write procedures for operations in which they are involved, rather than someone who has no usual contact with the vessel. In this way, procedures are more likely to be updated when changes occur.

Both the DOC and SMC were issued after the loading towers had been retro-fitted. A risk assessment of the loading towers, at the time they were fitted, might have indicated a need for written procedures for their operation during loading, and when using the forward tower for hanging-off the outhaul wire. As the company was embracing the ISM Code during the time the towers had been added, it is reasonable to expect that the requirements of the Code would have been borne in mind during major shipboard modifications.

Any major modifications to the vessel, or changes in the trading pattern, which result in operational changes to the vessel, should be highlighted to the MCA surveyor at the time of audit or inspection. The surveyor can then confirm that appropriate changes to the procedures manual have been made. The conversion to loading towers on *Arco Adur* was not highlighted to the MCA surveyor. Additionally, the master's review should point out significant changes which have occurred onboard and to the safety management system. There is no record in the master's review regarding the towers. The two internal audits did not highlight that the ship's procedures, regarding operations involving the cargo loading towers, were deficient or inconsistent with the company's generic procedures regarding risk assessment.

Apart from working with the grading screens, there appears to have been no input, regarding the operation and potential hazards of the loading towers on *Arco Adur*, from the two crews during the onboard safety meetings. There was an awareness by some of the crew of the hazard of standing on the aft platform. However, failure to raise this at a safety meeting, because they thought it would be stating the obvious, meant that the risk became acceptable to the crew. The company's Safety Management Manual highlights the importance of crew involvement in health and safety meetings, but unless this message is actively put across, crew members may not fully appreciate what the company expects of them, or the effectiveness of hazard reporting. It is in the company's interest, that crew members' concerns about health and safety aboard the vessel, are dealt with effectively, and that feedback is given when measures are deemed unnecessary.

Arco Adur's risk assessment folder had not been updated to include the loading towers, even though the company's Safety Management Manual specifically mentions this requirement when '*a change of operations or equipment*' has occurred.

The outhaul wire stowage operation was carried out on *Arco Adur* differently from the other three 'A' class vessels. Hanson Aggregates Marine knew and accepted the operation on *Arco Adur*, but the Safety Management Manual was not changed to reflect the difference in operation.

The ISM Code was not clear enough in the need for written procedures and checklists in its first edition guidelines. As such, a company with no established written instructions and procedures on its vessels may justifiably believe that an overview of the shipboard operation is suitable for their purpose. The company was satisfied that its SMS was effective, without being too onerous for the sea staff to work with. Additionally, the SMS had been approved by the MCA and the company had, therefore, met the requirements of the ISM Code. However, the ISM guidelines published by the ICS/ISF does mention the use of written instructions, and the need to keep them simple and unambiguous.

Hanson Aggregates Marine was aware of the ISF/ICS guidelines, but implementation of them was not evident in its SMS documentation. The guidelines expand and clarify the Code requirements to assist both the company, in the development of the SMS, and the surveyor, in applying the requirements. As the surveyor is not expected to pick up every failing in a safety management system, the ISF/ICS guidelines, although mandatory, can help shipowners to ensure that they comply with all aspects of the Code, regardless of external audits.

Since 1 July 2002, changes to the ISM Code have been introduced, which, in part, require a company to produce checklists for particular operations on board and to consider them for other operations as deemed necessary. The MCA is revising MGN 40 (M) to inform shipowners and masters of the need to comply with these changes.

That the hazardous incident, which occurred in 2001, was not reported is indicative of an SMS which is not working to its full potential. The crew members involved had attended safety meetings on several occasions, but were not aware of any discussions on the safe operation of the loading towers, except with reference to the hazards posed when the grading screens were changed. They were aware of the company's expectation that hazard awareness was important, and the crew members were expected to contribute to discussions. An accident reporting system was in place. However, there did not appear to be a strong commitment on the part of those on board the vessel to use it to reduce the working hazards on board, and the non-reporting of the incident is an indication of this mindset.

Crew members should be encouraged, without the possibility of redress, to report incidents of a hazardous nature to enable the company to assess the risks, and to implement suitable measures to remove or reduce the risk. Unless dangerous occurrences are reported by the crew to the management, the company cannot investigate, analyse and act upon any information received. The company should provide adequate feedback when responding to a report of a dangerous occurrence. Doing so, will encourage crew members to become involved in implementing safety on board the vessel.

2.5 CONTROL ERGONOMICS

The loading tower controls were also retro-fitted during the cargo loading equipment modification. However, no consideration was given to inform the operator of the operational state of the hydraulic power pack. The on/off press button switches did not illuminate when operated. The only interlock to prevent accidental operation of the towers was the requirement to pull the control joysticks upwards before they could be operated.

The equipment suppliers had not supplied instructions on the joystick panel for operation of the towers. The crew fitted the labelling tape instructions. However, the instructions were neither clear nor foolproof. Only after considerable practice in operating the joysticks did the operation become 'second nature'.

The aft tower joystick instruction 'slew aft' gave no indication as to which direction the tower would slew, either clockwise or anti-clockwise, as the operation was carried out by moving the joystick in either a forward or aft direction. The assumed logic is that the instruction is based on the movement of the loading chute before loading started. However, there were no written instructions for this.

During the MAIB inspectors' visit, the master operated the loading towers to help explain the operation. He forgot, temporarily, in which direction the joystick had to be operated. Although this could have been because of his state of mind after the accident, it does highlight the lack of logic applied to the design of the controls.

However, when the forward tower was used for outhaul wire stowage, it was probable that the operator leaned over the console and faced starboard. In that position, the operator had to turn more than 90° to look down to the aft loading tower. This could further increase the risk of mis-operation of the towers.

2.6 WORKING AND WATCHKEEPING ROUTINE

It is not unusual for a full complement of crew to join or leave the vessel at the same time. It is convenient for the company and has the advantage that a long-serving regular crew can often work better as a team. However, it can also pose problems for new recruits, as serious shipboard hazards may effectively be played down by the regular crew who are used to the shipboard equipment and operations.

2.7 OTHER RECENT ACCIDENTS

Two similar accidents to that on *Arco Adur* have been the subjects of investigations by the Australian Transport Safety Bureau (ATSB). A serious injury occurred to a crew member on board *CSL Pacific* in February 2002, and a fatal accident to a crew member on board *Western Muse* in June 2002.

The relevant conclusions from the *CSL Pacific* report are:

- *There was a lack of a suitable ship-specific procedure, consistent with the management company's safety policy, detailing steps for isolating cargo equipment prior to maintenance.*
- *Audits of the ship's safety management system prior to the incident failed to ensure that the procedures for isolating equipment prior to maintenance were adequate, consistent, and were being followed.*

The relevant conclusion from the *Western Muse* report is:

- *While the company and ship had the necessary ISM accreditation, the safety manual contained no precautions or procedures for the crew when working in close proximity to moving machinery on cranes.*

The investigation reports can be downloaded from the ATSB's website:
www.atsb.gov.au

SECTION 3 - CONCLUSIONS

The following safety issues have been identified from the foregoing analysis. They are not listed in any order of priority.

- The crew had proposed the method of hanging-off the port outhaul wire using the forward loading tower. No consideration was given to the safety implications of operating the loading tower while crew members stood in hazardous positions. In failing to carry out a risk assessment, two opportunities to curtail the operation were missed. Firstly, the hazard posed by operating the aft tower by mistake while a crew member was standing on the aft platform, and secondly, the incorrect use of the forward loading tower reject chute as a lifting device, a purpose for which it was not designed. [2.3.9]
- While the company and *Arco Adur* had the necessary ISM documentation, there was a shortage of suitable ship-specific procedures for deck operations, consistent with the management company's safety policy. This lack of procedures was not picked up during the vessel's safety meetings, the master's review or the internal and external audits. Although, originally, the ISM Code did not specify the need for written procedures for key shipboard operations, it was highlighted in the ICS/ISF guidelines to which the company had access.[2.4]
- Crew members on *Arco Adur* assumed that all on board knew that the forward loading tower was the one used for hanging-off the outhaul wire. Because everyone on board was deemed to understand the agreed hanging-off method, the potential hazard of standing on the aft platform, in case of inadvertent operation of the aft tower, was considered trivial and was not raised at a safety meeting. This unwritten understanding, although known to the regular crew, was not known by new crew members unless they had been suitably instructed and trained. [2.3.3]
- Once the induction form had been completed, further induction of new crew members was open to interpretation by the senior ship's staff. It was assumed that as the second officer had previously sailed on board *Arco Arun*, sister ship to *Arco Adur*, he would be conversant with operating the bridge navigating equipment and the controls for the deck machinery, and would require minimal instruction by the senior officers. There were no agreed prescribed methods for carrying out particular operations which were common to the 'A' class vessels. Common procedures would have ensured that crew, moving between these vessels, were conversant before joining with the onboard operations in which they would be involved. The required induction process would then be more straightforward. [1.11; 2.2]
- Had the previous hazardous incident been reported to senior ship's staff, and had they, in turn, included it in a hazardous occurrence report, the company would have been in a position to investigate why it had occurred. For a shipboard Safety Management System (SMS) to be effective, all crew members should understand that it is for their benefit. That the hazardous incident, or "near miss" had not been reported, is indicative of an SMS which was not working to its full potential. [2.4]

SECTION 4 - ACTION TAKEN

Immediately after the accident, **Hanson Aggregates Marine** promulgated a safety notice to the four 'A' class vessels which operate with cargo loading towers. This notice prohibited using the loading towers to secure the outhaul wires to the port coaming. A 'Permit to Work' was also required each time the wires were secured or 'let go' (**Figure 8**).

Further actions taken were:

1. A fleet-wide risk assessment of shipboard activities was instigated.
2. The operation which caused the accident was stopped, and the bucket wire access platforms moved so as to keep crew members clear of danger, regardless of the operation of the loading towers.
3. As applicable, all fleet management managers were trained or retrained in risk assessment.
4. An internal panel of enquiry, chaired by the managing director, was conducted.
5. The colour of company-issued boilersuits was changed from orange to a more highly visible yellow.
6. The carriage of a formally trained shipboard safety officer was made a requirement of the company's ISM system.
7. The need for sea staff to report hazardous occurrences was further emphasised, by issuing all sea staff and relevant shore staff with a hazardous occurrence report pad. This allows them to report any 'unsafe act', 'unsafe working condition' or 'unsafe equipment' they encounter. This supplemented the already established hazardous reporting procedures.

The Maritime and Coastguard Agency is revising MGN 40 (M) to inform shipowners and masters of the recent amendments which have occurred to the ISM Code. This includes a requirement to produce checklists for certain operations as appropriate, and the need to comply with these changes. [2.4]

The MAIB has written to Hanson Aggregates Marine Limited with the following recommendations:

1. Review the need for written procedures for the operation of hazardous equipment in company ISM documentation, in conjunction with the revised requirements of the ISM Code.
2. Review the induction procedures for new crew members.
3. Continue to involve regular vessel crews in the production of the above procedures. (Items 1 & 2)
4. Update company ISM documentation to reflect accurately new operations or equipment when they occur.
5. Review the need to stow the port outhaul wire.
6. Consider action necessary to encourage employees to use the existing formal reporting structure for hazardous incidents, or "near misses" in future.

SECTION 5 - RECOMMENDATIONS

In light of the actions taken by Hanson Aggregates Marine, the MCA and the MAIB no further recommendations are considered necessary.

**Marine Accident Investigation Branch
September 2003**