

Extract of Pilotage Directions and Guidelines



CLYDEPORT ESTUARY CONTROL



***PILOTAGE DIRECTIONS
AND
GUIDELINES***

Name Of Holder _____

CONTENTS

PAGE NUMBER

Document Control (Distribution List)	Two
Document Control (Record of Amendments)	Three
Contents	Four
Pilotage directions	Five/Six
Pilots working & holiday arrangements	Seven/Ten
General notes	Eleven
Additional information large vessels/berths	Twelve
Yorkhill Quay & Basin / Govan Basin	Thirteen
Sheldnall Riverside	Fourteen
Diesel Wharf / King George V Dock	Fifteen
Lohnitz Basin	Sixteen
Rothsazy Dock (Non Tankers)	Seventeen
Rothsazy Dock (Tankers)	Eighteen
Newark Quay / Great Harbour	Nineteen
James Watt Dock / Greenock Ocean Terminal	Twenty
Finnart / Holy Loch	Twenty One
Hunterston	Twenty Two
Appendix	
1 TUG EXEMPTION LISTS	Pages 23 / 24 / 25 / 26
2 PILOTAGE TIME AVAILABLE SHEET	Page 27
3 ADDITIONAL NOTES	Page 28
Note :-	Updated Tug Exemption List Will Be Recorded In Estuary Control Copy Of The Guidelines.

15. Relieving Times

In circumstances where a Pilot is not boarded within 24hrs. of becoming No.1 he will be relieved and his name put at the bottom of the duty roster. (This does not apply to grade 4 Pilots).

A pilot engaged to standby a vessel at anchor may request to be relieved after 9hrs. in attendance.

GENERAL NOTES

NOTE 1

For the purpose of these Guidelines, a 'Large' vessel navigating the river shall be deemed to be a vessel over 91.44m. (300ft) in length, and/or having a GRT of 3000t or over.

NOTE 2

It should be recognised that these are Guidelines and for good reasons there may be variations in the times selected by individual Pilots

NOTE 3

In special circumstances, the pilot should be consulted regarding times of berthing/sailing and number of tugs required.

NOTE 4

Vessels over 91.44m, (300ft.) in length and/or having a GRT of 3000t, or over, will usually require tug(s). Depending on manoeuvring characteristics.

NOTE 5

If possible, the trim of a vessel should not exceed 3mtrs.

NOTE 6

The maximum any-day draught for vessels proceeding to and from berths located east of Erskine Bridge and up to Shieldhall Riverside Berths is 8.7m in Fresh water.

NOTE 7

A "Small" Tug is a small Tug of 3 - 5 Tonne Bollard Pull.

A "Large" Tug is a Tug of 27 - 37 Tonne Bollard Pull.

A "Mid Size" Tug is a Tug of 10 Tonne Bollard Pull.

ADDITIONAL INFORMATION
Large Vessels/Berths

Guidelines for Vessels over 200 metres proceeding to Glasgow

Tidal Transit

Maximum Wind Speed 15 Knots

Daylight Transit

Check Air Draught (Erskine Bridge Clearance)

Depth Of Harbour (Safe Ground)

Tugs – 4 Berthing / 3 Sailing

Fresh Water Arrival Draught To Be Confirmed

CONSULTATION TO BE CONDUCTED.

Vessel Dimensions Not Exceeding	Fresh Water Any-day Draught	Fresh Water Consultation Draught
200m x 30m	8.7m	9.4m
210m x 30m	8.7m	9.2m
220m x 31m	8.7m	9.1m
230m x 32m	8.4m	9.0m

NOTE :- For large vessel transits & changeover berths at Shieldhall, see Quality Work Instructions.

Rothesay Dock Berths 1/2

Maximum Length 120 metres L.O.A.

Maximum Arrival Draught 8.0 metres.

Draught Must Be Reduced To 6.0 metres By Low Water Glasgow To Remain Always Afloat.

DIESEL WHARF

ARRIVING

Vessels should arrange to berth on the Flood Tide.

SAILING

Vessels should arrange to sail from about 1hr. To High Water Glasgow.

Vessels over 75mtrs. L.O.A. (No Fwd. Thruster) will require a small tug to assist.
The maximum draught calculation formula is Height of Tide + 2.5m minus 10%

KING GEORGE V DOCK

ARRIVING

Large vessels will usually enter the river 3½hrs. before High Water Glasgow.

Vessels over 152 metres berthing Head North will require 3 tugs.

SAILING

Vessels over 8 metres draught will usually sail at or about Half Flood Glasgow depending on draught.

Assessment of load required to girt *Flying Phantom*

Vessel: **Tug 'Flying Phantom'** stability analysis using MAST

Condition.: Derived loss scenario
 State: Main Hull, Nozzle Etc., Thruster and Deckhouse
 Water SG: 1.025

Longitudinal dimensions about AP (-ve aft, forward)

Vertical dimensions about Base Line (above, -ve below)

Deadweight Item	Weight tonnes	LCG metres	Longitudinal moment t.m	VCG metres	Vertical moment t.m	Free Surface moment t.m
1 Oil Fuel DB Tk 40-57 P	12	25.11	301.32	1.744	20.928	28.11
2 Oil Fuel BD Tk 40-57 S	12	25.11	301.32	1.744	20.928	28.11
3 Oil Fuel Daily Service Tk	4.42	16.96	74.963	6.14	27.139	0.2
Total Oil Fuel	28.42	23.842	677.603	2.428	68.995	56.42
4 Fresh Water Tk 8-12 P	9.5	5.34	50.73	3.931	37.345	4.57
5 Fresh Water Tk 8-12 S	9.5	5.34	50.73	3.931	37.345	4.57
Total Fresh Water	19	5.34	101.46	3.931	74.689	9.14
6 Water Ballast Tk 2-8 P FW	7.5	2.79	20.925	4.242	31.815	10.79
7 Water Ballast Tk 2-8 S FW	7.5	2.79	20.925	4.242	31.815	10.79
8 Water Ballast Tk 24-39 P	0	0	0	0	0	0
9 Water Ballast Tk 24-39 S	0	0	0	0	0	0
10 Water Ballast Tk 57-60 C	0	0	0	0	0	0
11 WB Tank Fore Peak FW	26.38	32.85	866.583	4.827	127.336	0
Total Water Ballast	15	2.79	41.85	4.242	63.63	21.58
12 Foam Tank 21-39 C	32.79	16.41	538.084	0.622	20.395	23.25
13 Detergent Tank 40-44 C	9.97	22.26	221.932	1.412	14.078	3.22
14 Small Tanks	5.05	17.29	87.315	2.99	15.1	0
15 Crew and Effects	1	26.75	26.75	5	5	-
16 Stores	0.5	21.48	10.74	5.02	2.51	-
17 Towing Gear	3	15.9	47.7	5	15	-
DEADWEIGHT TOTAL	141.11	18.567	2620.017	2.882	406.733	113.61
LIGHTSHIP	470.5	15.87	7466.835	4	1882	-
DISPLACEMENT	611.61	16.492	10086.85	3.742	2288.733	113.61
Free Surface Correction (Total FSM/Displmt)	0.186					
VCG fluid	3.928					

DRAFT SUMMARY (DIMENSIONS IN METRES)

	Maximum	Actual
Draft forward (about USK at FP)	-	2.637
Draft midships (about USK)	3.837	3.79
Draft aft (about USK at AP)	-	4.942

STABILITY DATA

Heel angle degrees	Trim about Base Line metres on LBP	Draft at midships LBP about Base Line	KN metres	KGxSIN(Heel) metres	Righting moment tonne.metres	GZ fluid metres
0	0.606 by stern	3.598	0	0	0	0
5	0.603 "	3.593	0.401	0.342	35.986	0.059
10	0.544 "	3.536	0.807	0.682	76.322	0.125
15	0.493 "	3.455	1.194	1.017	108.461	0.177
20	0.454 "	3.358	1.545	1.343	123.02	0.201
25	0.441 "	3.248	1.859	1.66	121.914	0.199
30	0.451 "	3.118	2.146	1.964	111.485	0.182
35	0.485 "	2.966	2.409	2.253	95.675	0.156
40	0.539 "	2.786	2.652	2.525	77.771	0.127
45	0.625 "	2.58	2.875	2.777	59.578	0.097
50	0.735 "	2.345	3.082	3.009	44.444	0.073
55	0.867 "	2.081	3.273	3.218	33.992	0.056
60	1.014 "	1.799	3.435	3.402	20.368	0.033
65	1.165 "	1.503	3.56	3.56	0.323	0.001
70	1.312 "	1.199	3.648	3.691	-26.096	-0.043
75	1.449 "	0.889	3.701	3.794	-56.671	-0.093
80	1.579 "	0.576	3.722	3.868	-89.696	-0.147
85	1.716 "	0.259	3.709	3.913	-124.77	-0.204
90	1.858 "	-0.06	3.665	3.928	-160.543	-0.262

Angle of immersion of Port ER vent - 42.097 (degrees)

Red Jasmine / Flying Phantom Geometry

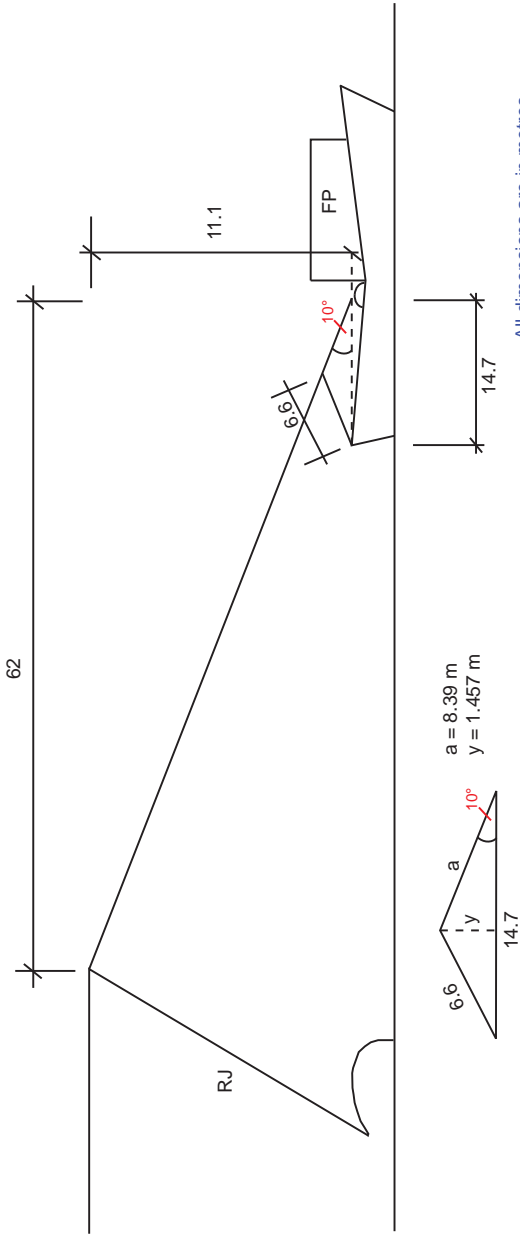

$a = 8.39 \text{ m}$
 $y = 1.457 \text{ m}$

All dimensions are in metres

MAIB Safety Bulletin 2/2005, published June 2005

MAIB SAFETY BULLETIN 2/2005

Collisions and contacts
between tugs and
vessels under tow or escort
in United Kingdom ports

MAIB SAFETY BULLETIN 2/2005

This document, containing safety lessons, has been produced for marine safety purposes only, on the basis of information available to date.

The Merchant Shipping (Accident Reporting and Investigation) Regulations 2005 provide for the Chief Inspector of Marine Accidents to make recommendations at any time during the course of an investigation if, in his opinion, it is necessary or desirable to do so.

A number of collisions between harbour tugs and the vessels they were assisting have been reported recently to the MAIB. Investigations have highlighted a number of safety issues shared by each of the collisions. It is these shared issues which prompted this Safety Bulletin.

A handwritten signature in black ink, appearing to read 'Stephen Meyer', with a long horizontal stroke extending from the end of the name.

Stephen Meyer
Chief Inspector of Marine Accidents

This bulletin is also available on our website: <http://www.maib.gov.uk>

Press Enquiries: 020 7944 3232/3387; out of hours: 020 7944 4292

Public Enquiries: 020 7944 3000

INTERNET ADDRESS FOR DFT PRESS NOTICES:

<http://www.dft.gov.uk>

BACKGROUND

During the first 4 months of 2005, the MAIB has been notified of three significant collisions involving harbour tugs. In the first incident, a tug running stern first ahead of a merchant vessel lost control, turned broadside across the bow of her charge and was holed beneath the waterline. In the second, a tug guiding the stern of a merchant vessel moving stern first lost control, struck the stern, and ended up with her tow line wrapped completely round her bridge superstructure. In the third incident, a tug attempting to pass a line to a merchant vessel underway lost control, ran in under the bow and struck the bulbous bow. Fortunately, in two cases the damage was reasonably minor; in the third, the tug had to be beached. No lives were lost, however the consequences could have been much worse.

The common theme to all three of the above incidents was that the tug master, although in each case quite experienced, was operating a tug with an unfamiliar propulsion system, and was attempting a manoeuvre with that system for the first time. The tug propulsion systems in the three incidents were not the same, however, each required a very different thought process on the part of the tug masters to manoeuvre the vessels effectively and safely when compared to the systems they were accustomed to. The key point is that, although the tug masters had a wealth of professional experience, they had received insufficient training and familiarisation with the systems they were using when the collisions occurred.

SAFETY LESSONS

MAIB strongly urges that:

- All tug operators review their training schemes, to ensure that tug masters receive comprehensive familiarisation training before taking control of a tug which is equipped with a significantly different propulsion system. Such training should incorporate instruction and validation on all manoeuvres that the tug master is likely to be tasked in the port.
- All harbour authorities, pilots and tug operators regularly review the capabilities and limitations of their harbour tugs and their crews, to ensure a common understanding of each tug's strengths and weaknesses. This should be supplemented for each towing task with a local appraisal of the intended operation to ensure the "tug to task" allocation is appropriate before the tow or move begins.

Svitzer Safety Memoranda



DO IT SAFELY OR NOT AT ALL

GROUP SAFETY MEMORANDUM 2/2008

THE DANGERS OF GIRTING

A recent incident has highlighted the dangers of tugs being girted whilst towing on a line. The incident in question is still under investigation and it will be some time before the internal report into this investigation can be circulated. Without pre-judging the results of the investigation, all tug crews within SVITZER are to be reminded of the dangers of girting. In particular, Tugmasters must be reminded of the need to test the Quick Release mechanisms for tow hooks and winches prior to every towage operation – they could be a lifesaver in the event of an emergency.

TOWAGE IN FOG OR SEVERELY RESTRICTED VISIBILITY

Towage in fog or when there is severely reduced visibility for other reasons (such as heavy snow or a sand storm), is always difficult but can be done safely if the proper precautions are taken. Any particularly challenging manoeuvres or transits must be subject to local risk assessment, and where possible careful pre-planning with all parties involved. This should include discussions with the Tugmasters and where possible the pilot and Port Authority. Such a risk assessment must include consideration of acceptable speed under different environmental conditions and contingencies in the event of changing conditions during the operation. The assessment might conclude that towage can only take place above a certain minimum visibility. Good communications and co-operation between the tugs, pilot, vessel being towed and the Harbour Authority will be essential.

MASTERS OVER-RIDING AUTHORITY

All tug masters should be reminded that they have an over-riding authority to take whatever action is necessary to ensure the safety of their crew and their vessel. This can include refusing to connect a tow, or in extreme circumstances taking action to disengage from a tow if they consider their tug to be in danger.

Remember, in SVITZER:

- 'We do it Safely, or Not At All
- If in DoubtSTOP

Copenhagen, January 2008

SVITZER

Svitzer UK Safety Memorandum No 3 – 2008

TO: Regional and General Managers; Technical Superintendents and Marine Superintendents
All Tug Masters and Crews

CC:

FROM: Chief Safety and Development Officer

SUBJECT: **Towage in Restricted Visibility**

Towage in Restricted Visibility

The purpose of this Safety Alert is to once again remind Tug Masters, crews and management of the risks associated with assisting vessels in restricted visibility.

Restricted visibility means all circumstances where visibility is or is expected to reduce to a distance where the tug's normal ability to perform may be impaired (i.e. fog, mist, falling snow, rain, sleet or sandstorm).

Tugs can safely assist vessels in conditions of restricted visibility, but only if a thorough risk assessment and a passage plan has been carried out and agreed with all the parties involved in the operation.

The specific dangers associated with towing on a line in such conditions, particularly for the head tug, must be considered and risk reduction measures agreed prior to commencement of the operation. If in doubt the Tug Master must refuse to tow by this method.

Svitzer UK Safety Memorandum No 3 – 2008

Risk Assessments

Risk assessments have already been carried out on each tug for their suitability to work in normal visibility within the port where they operate.

Risk Assessments in Restricted Visibility

Where restricted visibility is present or expected Tug Masters must carry out a specific risk assessment which must include in addition to any other identified potential hazards

- The suitability of the tug to operate in the current or expected conditions of restricted visibility
- The operational status of all navigational aids and equipment.
- The type of vessel to be assisted and in particular the minimum and maximum speeds which will be encountered during the operation.
- The terminal or berth to or from which the vessel is to be moved.
- The tug assist methods that might be used.
- The movement of other vessels in the area.
- The navigational characteristics of the particular area of the port including the use of information from Vessel Traffic Services.
- The characteristics of the other tugs which will be involved in the operation.
- The level of experience of the Tug Master and the crew.
- The contingency plans which may be required including one covering the situation where the tug has to disengage because the Tug Master considers the crew or the tug to be in danger

Svitzer UK Safety Memorandum No 3 – 2008

Pilot / Master / Tug Master Communications

It is imperative that the Tug Master communicates with the Pilot/Master of the vessel to be assisted as soon as practicable, to plan the operation with the full knowledge of any restrictions that may apply. Contingency plans should be agreed in case these circumstances change.

It is essential that good and seamanlike communication continues throughout the operation and the Tug Master must inform the Pilot/Master of the towed vessel of this requirement.

In particular the Tug Master must inform the Pilot / Master of the following:

- Any limitations on the tug's ability to assist.
- The maximum permissible speed at which any manoeuvre may have to be carried out.
- The necessity to provide information well in advance to the tug of all engine movements and alterations of course of the towed vessel.
- The necessity to inform the tug immediately of any changes in the towed vessel's circumstances.
- If a Tug Master believes his tug is being put at risk or he is not comfortable with the tug's position relative to the vessel

All the tugs involved in the operation must also maintain communications with each other throughout the operation.

Svitzer UK Safety Memorandum No 3 – 2008

Port Authority Risk Assessments

Under the Port Marine Safety Code (PMSC), Port Authorities should have undertaken operational risk assessments for vessel movements within the port in conditions of restricted visibility, and drawn up guidelines or regulations. However, they may not have taken into consideration the risks which may apply to the towage services during such vessel movements and they must be made aware of the risks identified by Svitzer in the conduct of such operations.

Svitzer port management must therefore liaise with the local Port Authorities to ensure that any port guidelines or regulations take account of and mitigate the risks associated with the use of tugs in restricted visibility and that all parties are aware of them

In ports where regulations and guidelines exist on restricted visibility they must be reviewed regularly. Where there are no specific regulations or guidelines or they do not cover the operation adequately the management must seek to have them revised.

The Port Authorities must be made fully aware of and understand the company procedures within the port for the towage of vessels in restricted visibility.

Masters Over-Riding Authority

All Tug Masters are reminded that they have an over-riding duty and authority to take whatever action they consider necessary to ensure the safety of their crew and their tug. This can include refusing to connect to a tow or taking action to disengage from a tow if it is considered necessary for the safety of the tug and crew.

Svitzer UK Safety Memorandum No 3 – 2008

Attention is also drawn to SVIMS

Svitzer UK Operations Manual	3.4 Watchkeeping Responsibilities
Svitzer UK Operations Manual	3.5 Navigating within Harbour Limits
Svitzer UK Operations Manual	3.6 Navigating in Restricted Visibility

Chief Safety and Development Officer
20th June 2008

Lloyd's Register Safety Alert -
Recommendations for tugs undertaking towing operations

CLASSIFICATION NEWS

July 25, 2008

No. 20/2008

SAFETY ALERT Recommendations for tugs undertaking towing operations

APPLICABILITY All owners and operators of tugs engaging in towing operations

INFORMATION Serious concern has been raised within the marine industry about the arrangements used by tugs when carrying out towing and the potential dangers involved in such operations. The importance of risk assessments and efficient quick release gear has been highlighted.

To help ensure the safety of tugs when carrying out towing, attention should be paid to the following recommendations:

1. Before any tow, a suitable risk assessment should be carried out. This should take into account all applicable scenarios, including: dangers associated with towing; weather; and the competence, training and experience of the tug's crew.
2. The emergency quick release gear should be tested to make sure it is working efficiently at all the stations from which it can be operated.
3. All watertight doors and openings should be closed and made tight during the tow.
4. Communication systems between the tug and tow should be verified.

When following these recommendations, particular attention should be given to:

- the towing arrangements between the tug and tow and the dangers of **girting**
- potential problems resulting from the quick release of the towline
- potential problems resulting from sudden loss of the tug's propulsion power.

HELP US TO HELP YOU – if you are an owner or operator and require further assistance, please get in touch with your local Lloyd's Register Group office at the earliest opportunity and we will be happy to assist.

Further information

Contact: Tom Dalling
T +44 (0)23 80 525720
F +44 (0)23 80 525799
E tom.dalling@lr.org

www.lr.org

© 2008 Lloyd's Register

Services are provided by members of the Lloyd's Register Group.
Lloyd's Register is an exempt charity under the UK Charities Act 1993.

Lloyd's
Register

LIFE MATTERS

Examination and testing of the towing winch, undertaken on board the tug
Flying Phantom after salvage, alongside King George the Fifth Dock,
Glasgow, January 2008

SECTION 1 PURPOSE AND BACKGROUND

1.1 PURPOSE

The purpose of this document is to record the examination and testing of the main towing winch and associated ancillary systems, as found on board the tug *Flying Phantom* after she was salvaged. This process was undertaken as a part of the MAIB investigation into this accident.

It also records the recovery of the tow rope from the winch drum; this was then seized by Strathclyde Police as evidence. Examination of the tow rope has been undertaken by specialists and will be the subject of a separate report.

This document will present conclusions as to the status of the winch system on board *Flying Phantom* at the time of the accident.

1.2 BACKGROUND

The tug *Flying Phantom* was involved in an accident while acting as bow tug, towing the bulk carrier *Red Jasmine* up the River Clyde on 19 December 2007. This resulted in her capsizing to her port side and consequently sinking. Three lives were lost; one crew member survived.

The tug remained on the river-bed for over 30 days, before being salvaged. *Flying Phantom* was then delivered afloat at the King George the Fifth (KGV) Dock, Glasgow on 21 January 2008. At that time she was declared a constructive total loss.

Key to understanding the capsize, was an investigation of *Flying Phantom's* towing winch system, and the tow release arrangements. Investigators needed to determine if the release system had been activated and, if so, had it functioned correctly.

As this investigation and consequent tests would disturb the systems, and in so doing destroy some evidence, it was agreed that MAIB would coordinate and direct the investigation activities, with other interested parties attending primarily as witnesses.

1.3 FLYING PHANTOM TOWING WINCH MANUAL

Extracts of the *Flying Phantom Winch Manual AHS 2876*, are included at **Appendix 1**.

SECTION 2 ARRANGEMENTS FOR INSPECTION & TESTING OF THE TOWING WINCH ON BOARD *FLYING PHANTOM*

2.1 ATTENDEES AT INSPECTION

The following were present during the inspection of the towing winch:

- MAIB inspector - provided independent overview of inspection
- Strathclyde Police - controlled access to vessel, took photographic evidence and maintained overview of events
- MCA surveyor from Greenock office - represented MCA in role as marine experts to Strathclyde Police
- SGS UK Ltd, Grangemouth - provided chemist to certify atmosphere of enclosed spaces was safe to enter
- Dales Marine Ltd, Aberdeen - were engaged by Svitzer Marine Ltd owners to provide advice on the mechanical condition of the towing winch, to assist with testing, and dismantling of mechanical assemblies as required
- Invotech Electrical Services Ltd, Loch Lomond - as a subcontractor to Dales Marine Ltd, provided advice and tested electrical systems as directed
- Hays Hydraulic and Mechanical Services Ltd, of Westhill - also as a subcontractor to Dales Marine Ltd, provided advice and tested hydraulic systems as directed
- The regular chief engineer of *Flying Phantom* - attended to give advice on normal operations of the tug and the equipment on board
- IMC Corp Licensing, from the Netherlands and consultants from Safety at Sea Ltd - attended as representatives of Svitzer Marine Ltd's insurers.

2.2 PREPARATIONS FOR TESTING OF THE TOWING WINCH

- Location and duration

Tests were undertaken with the tug moored alongside at KGV dock, Glasgow; work was possible within daylight hours only.

Work began at 0900 on Tuesday 22 January 2008 and was completed at noon on 7 February 2008.

- Condition of the vessel

The vessel was made as safe as reasonably practicable for the duration of these tests. However, the vessel was “dead ship” – without any means of power, ventilation or lighting. Temporary arrangements for the provision of services were made as necessary.

Dangerous enclosed/confined spaces were ventilated and then certified safe to enter by the Shipping Chemist; hazardous materials were then removed as far as reasonably practicable.

In order to protect the surrounding environment, the tug was fully enclosed by an anti-pollution boom.

Excess flood water was pumped out using portable pumps; water levels were minimised and restricted access to most compartments was made possible.

SECTION 3 TOWING WINCH - OVERVIEW

3.1 GENERAL ARRANGEMENT OF THE WINCH SYSTEMS

The towing winch system on board *Flying Phantom* was fitted in 1997, replacing the towing hook originally fitted to the tug when built.

The locations of the components of the winch system on board *Flying Phantom* are shown in the attached figures (**Figures 1A & 1B**).

3.2 OPERATION OF THE WINCH – OVERVIEW

The towing winch could be operated either locally (by means of a mechanical lever, which operated a valve in the hydraulic system at the winch side, on the aft deck) or remotely from one of the three remote control stations in the wheelhouse. At the time of the accident the winch was being operated from the wheelhouse.

From all positions, the initial movement of a control lever causes the winch brake to be released, the oil pressure then provides motive power to the winch. The controls are arranged so that the speed of the winch is proportional to the movement of the control lever.

3.3 TOWING WINCH REMOTE CONTROLS IN THE WHEELHOUSE

The wheelhouse winch controls consisted of three very similar electrically operated control panels, one each to port and starboard forward; the aft panel was in the centre. The starboard forward panel was the master and had additional pushbuttons for remotely starting and stopping the winch power pack. Each of the three winch control panels was provided with an emergency release button (ERB). These were of the “lock on” type (i.e. once operated they remained depressed, until manually reset), as commonly seen on machinery stop controls.

Normal heave/veer operation of the winch was achieved using spring loaded self-centring electrical control levers, one on each of the wheelhouse panels (**Figure 2**).

Operation of the electrical remote controls in the wheelhouse sent a 24 volt control signal, to the winch hydraulic power pack, where an electro-mechanical interface operated the winch hydraulic systems.

3.4 DISPOSITION OF WINCH SYSTEMS

- General arrangement - deck workshop/store compartment

The deck workshop/store compartment contained the winch control and power systems:

- The towing winch electrical control box,
- The towing winch hydraulic power pack, together with the associated compressed air supply system, air driven accumulator pump and hydraulic accumulator,
- The hand operated winch brake jacking pump.

This compartment consisted of a small (approximately 2.5 x 1.25 m) full height deck workshop, entered through a steel watertight door, over a storm sill from the starboard side main deck (the deck below the wheelhouse). The door arrangements consisted of six clips, sealing the door on to a rubber gasket. All were in a satisfactory condition; the door was closed at the time of the accident.

Opening off this area, was a half height compartment which extended almost the full width of the deckhouse casing, to give an area about 2.75 x 4.25m, which was primarily used as a deck gear store. This compartment was above the main deck, beneath the tow wire spools. The heavily reinforced aft vertical bulkhead of this space formed the foundation on which the towing winch was mounted.

The space was ventilated by two small natural vents on the aft bulkhead at a height of about 1.2 m over deck, closed off by hinged steel covers (in satisfactory condition) which were closed at the time of the accident. There was also one glass port-light in the aft bulkhead, in the far port side corner of the store space. The port light glass was found closed, with the internal steel deadlight not closed. When forcibly smashed by the investigator (for safety reasons - in order to promote ventilation of this confined space) the glass was found to be of the correct dimensions and type (**Figure 1A & 1B**).

- Winch electrical control box

The winch electrical control box was mounted on the vertical bulkhead, inside the deck workshop, facing the starboard side. Push buttons for

local starting and stopping the winch system (replicating those found in the wheelhouse), together with a green “running” indicator light were mounted on the door of the control box.

- Winch hydraulic power pack - system overview

The winch hydraulic power pack was mounted inside the deck store, on the starboard side, orientated in the fore/aft direction.

Under normal conditions this unit supplied motive power to the winch using two electrically driven hydraulic pumps mounted on top of the oil sump tank. The electrical supply was from the ship’s main power system. The pumps supplied oil under pressure to a hydraulic motor mounted on the starboard side of the winch frame; some of the oil pressure was used to release the towing drum brake, which was normally held on by the brake springs.

The winch power pack was normally supplied with high pressure compressed air from the engine room via an isolating valve and an in-line reducer mounted within the store compartment. The compressed air provides the motive force to drive the hydraulic accumulator pump; the pump then pressurises the hydraulic accumulator.

A bladder type hydraulic accumulator was vertically mounted on the aft end of the power pack, with the hydraulic connection at the bottom. The accumulator stores the energy necessary to release the tow rope under emergency conditions. It releases the winch brake, and also configures the hydraulic pump to pay out, so allowing the winch drum to rotate and slack off the tow rope (**Figure 3**).

3.5 HYDRAULIC POWER PACK - SYSTEM DETAILS

- Compressed air supply

The compressed air supply to the hydraulic accumulator pump (**Figure 1B and Figure 3**) was fed from an air storage cylinder in the engine room; the storage cylinder was charged by an air compressor.

- Winch brake operating system - hydraulic accumulator

Fluids are practically incompressible and cannot store pressure energy. An accumulator is therefore commonly used as a means of storing energy in hydraulic systems. The bladder type hydraulic accumulator consists of a fluid section and a gas section, with the bladder acting as a gas-proof screen. The fluid around the bladder is connected with the hydraulic circuit, so that the bladder accumulator draws in fluid when the pressure increases, thus compressing the gas. When the pressure drops, the compressed gas expands and forces the stored fluid into the circuit. Under normal conditions, the bladder type hydraulic accumulator is charged by both the main hydraulic pumps and the air driven pump (**see Figure 3**).

3.6 WINCH BRAKE EMERGENCY RELEASE OPERATING SYSTEMS

- Main system

Depressing any one of the three ERBs in the wheelhouse would cause the winch brake release system to operate. This was achieved by an electrical control signal that was sent from the wheelhouse to an electrically operated solenoid valve in the hydraulic system; the solenoid valve was mounted on the top of the power pack unit. The electrical signal caused the valve to supply oil pressure so as to operate the brake release system.

By utilising the stored energy within the accumulator, the release operation was designed to be possible irrespective of the condition of the hydraulic power pack itself (for example, if the tug had lost electrical power).

- Hand operated winch brake pump

A self contained hand operated winch brake jacking pump was mounted inside the store space, on the aft bulkhead near the port light. Manual operation of this pump supplied hydraulic oil to the winch brake, allowing the brake to be released in the event of failure of the hydraulic power pack (for example in a “blackout” condition).

This manual pump was connected via a 90 degree swing cock in the main winch hydraulic circuit; the cock was located outside on the main deck next to the winch on the port side, marked “Emergency Brake Override”. Once connected, the hand pump operated entirely separately from the main towing winch hydraulics system (**Figure 1B**).

This pump unit was not directly involved in the accident.

3.7 WINCH BRAKE

The winch brake was of the external band type, whereby a brake band (lined with friction material) is tightened around the outside of a brake drum, which is attached to the winch drum. In this case the band was normally held on by the action of the pre-load from the brake springs, i.e. the brake would tend towards “on” in the absence of any control force to take it “off”. Therefore the tow rope is restrained by the winch brake, meaning that the tug tows against the brake rather than the force of the winch itself. The degree of initial restraining force is set by adjusting the pre-load on the brake springs (**Figures 4 and 7**).

SECTION 4 INITIAL INSPECTION – AS FOUND

4.1 WINCH CONTROLS WITHIN THE WHEELHOUSE

The MAIB inspector on scene when *Flying Phantom* was brought to the surface during the salvage operation had entered the wheelhouse on 21 January, as soon as it was above water, and before salvors began work inside the wheelhouse. The scene was photographed as found, then again with the worst of the mud carefully washed away, so that switch positions could be clearly seen. All panels were intact and appeared largely undamaged.

The MAIB inspector noted that the winch ERB on the forward starboard towing winch control console, immediately inside the starboard wheelhouse door was depressed, i.e. it had been operated, so as to release the tow (**Figure 5**).

The other two winch ERBs were found not to have been depressed and were in their normal operating position.

The towing winch heave/veer joystick controls were all found in the neutral position; however, these controls were of the spring loaded self-centring type and would return to the neutral position when released.

It was not possible to determine the status of the pushbuttons on the control panels as that information was not stable; the design of these buttons was such that indication was not retained after the accident.

The same MAIB inspector was present when *Flying Phantom* was first boarded on 22 January, alongside at KGV, and it was noted that the evidence did not appear to have been disturbed. The controls were photographed before any further work was undertaken; then again after the panels had been fully washed down to allow details of the control labels to be read.

4.2 DECK WORKSHOP/STORE COMPARTMENT AND WINCH MACHINERY ARRANGEMENTS WITHIN

- Winch electrical control box

The box was undamaged, and when opened the internal wiring and switchgear were found intact and dry. These controls appeared to be as they would have been with the winch running.

- Winch hydraulic power pack

Despite negative first impressions of the condition of this space (as a result of capsizing and flooding), once emptied of loose gear and water, none of the winch control or hydraulic power equipment within this

compartment was found to have been seriously damaged during the accident.

The winch hydraulic power pack was visually inspected by the hydraulic engineer. The unit appeared to be substantially undamaged, but had become fully immersed during the accident.

The hydraulic oil level in the power pack sump tank appeared normal, and was at the correct level. However, given the circumstance it was likely that this oil could have become contaminated as a result of immersion following the accident. It was considered to be unlikely that representative system oil samples could be obtained, therefore samples were not taken.

- Compressed air supply system

The air supply system valves, at the air storage cylinder in the engine room, were found in the normal operating position, i.e. open.

A warning notice stating that the air supply isolating valve in the store was to be open when towing, was prominently displayed next to this valve. The valve in the store was found in the open position (**Figure 3**).

- Air driven hydraulic accumulator pump and accumulator unit

The hydraulics engineer visually inspected the winch air driven accumulator pump and the accumulator unit. No apparent damage was found.

- Hand operated winch brake pump

The hand pump was visually examined, and appeared to be undamaged. The change over cock (next to the winch on the aft deck) was found in the normal position, whereby the main hydraulic power pack was operating the winch brake (**Figure 7**).

4.3 TOWING WINCH UNIT – AFT DECK

- Location and orientation of the winch installation

The winch was seen to be mounted on the vertical face of the after bulkhead of the superstructure of the tug, and not attached to the deck as would more commonly be the case. The MAIB was advised that this was because the winch was retrofitted to the tug, in place of the original towing hook. The hook was fitted to the bulkhead, which was therefore built as a structure strengthened to take towing loads; the deck was not strengthened to take towing loads. It was therefore logical to mount the new towing winch on the bulkhead, rather than attempt to reinforce the deck. A brief visual inspection of the steel structure adjacent to the winch confirmed this information.

It is understood that some modifications to the winch have been made to allow it to be mounted in the vertical, rather than horizontal plane. However, details of any modifications to the original winch design were not available.

- General appearance and overall condition

The winch was well greased, and first impressions were of a generally well maintained machine, that was lightly used. The winch did not appear to have been significantly damaged during the accident. No evidence of physical overload was seen, there was no visible distortion of winch structure, or the area of its attachment to the tug.

- Local winch control lever

Located on the main deck, immediately adjacent to the starboard side of the winch, this self-centring control lever was provided to give local control of the heave and veer functions. This lever was found in the centre, or zero position.

- Winch drive motor

The hydraulic drive motor, mounted on the starboard side of the winch frame had no external indication of damage, and appeared to be in a satisfactory condition. All associated hydraulic oil pipe work was similarly satisfactory.

- The towing winch brake

The brake was found to be on, operated by the springs as would be expected. No significant damage or deformation of the brake operating system was seen, and it appeared to be in a satisfactory condition.

It was noted that the brake actuating linkage system was attached to the brake band by a single point on the forward face of the brake band only; there was no direct attachment to the band on the after section of the brake band. As a result, the brake band tended to “float” about the forward attachment point.

Although “on”, the brake band was seen to be unusually displaced over towards the port side, and the area of brake drum left exposed (a strip about 15 – 25 mm wide around the full circumference of the brake drum) was clean and bright. This could indicate that after the accident the band was not found in its usual position. This was confirmed by the vessel’s chief engineer, who stated that he had not seen the brake band displaced like this before (**Figure 6**).

- Tow rope on the winch drum

The winch drum was approximately two thirds full of tow rope, of a type that appeared similar to that which had been seen by the attending

MAIB inspector on the foc'sle deck of the ship *Red Jasmine*, and recovered from that ship as evidence. That section of rope was seized by Strathclyde Police and MAIB as evidence.

The rope on the winch did not appear to be spooled unusually on to the tow winch drum, or particularly compressed as if significantly overloaded. The tow rope had parted at a position about 9 metres from the drum, approximately in the position of the bridle winch shackle. No deformation of the bridle winch shackle was seen.

- “Goal post” arrangement

The tubular structure surrounding the aft side of the winch (the “goal post”), used to help guide the tow rope on to the winch drum), was not damaged, and showed no unusual witness marks from the tow rope. At the time of the accident, the tow rope did not appear to have been running off the drum in any way other than that which was normal **(Figure 4)**.

- Winch assessment

At this time, the attending specialists and investigators agreed that partial dismantling would be advantageous. Dismantling would be limited to giving improved access to components and operating systems, while maintaining the possibility of later operating the winch under power.

The winch was photographed and examined as found, before being partly dismantled by specialist winch engineers for closer inspection.

4.4 WINCH INSPECTION - PARTIALLY DISMANTLED

The winch was then partially dismantled by specialists, as directed by the attending investigators and experts. This work was also witnessed by officers from Strathclyde Police. Findings were as follows:

- Brake springs

The brake springs were not visible with the winch in an operating condition. A sheet metal guard covered the brake springs (on the port side of the winch); this was removed to allow inspection of the springs. The aft most of the two springs was seen to have fractures in its lower part, such that approximately two coils were broken off from the lower part of the spring. However, no parts were missing. The disposition of the broken parts and dirt, grease and corrosion in the area around them indicated that this damage pre-existed the accident, and also that the brake spring settings had not been recently adjusted, or interfered with. This supposition was agreed by the attending investigators **(Figure 7)**.

The broken spring would, to some degree, reduce the winch brake spring pre-load.

- Winch drum bearings and shaft

Both main winch drum shaft bearings were opened up for examination. They were found to be well greased and in a satisfactory condition. There was some evidence indicating that difficulties might have been experienced with these bearings in the past; witness marks relating to work undertaken some time ago were found on the port side end of the main shaft. Closer examination resulted in the opinion that this was not related to this accident.

- Winch drive gears

The sheet metal guard covering the hydraulic motor drive pinion and the driven winch gear wheel was removed for inspection of the spur gear type drive system. No damage, or evidence of overload was found, and they appeared to be in a satisfactory condition.

SECTION 5 TESTING THE WINCH

5.1 ELECTRICAL TESTS OF THE TOWING WINCH REMOTE CONTROL SYSTEM

The electrician examined, and using calibrated instruments tested, the winch control system in the wheelhouse; his findings were as follows:

- The supply box, under the chart table on the port side was opened up and tested: The 24V electrical supply wiring was unbroken; fuse ratings correct, fuses intact and no damage.
- The access panel below the starboard winch control panel (master) was removed to test that the ERB push button activated (pushed down and locked down correctly) to release the brake. This was a normally open switch, pushing closes it and energises the control circuit. This switch was tested and, despite having been immersed for about a month, it was found operational. One terminal of the winch heave/veer control joystick was found disconnected, but it was seen to be clean and bright and attending investigators agreed that this appeared to have occurred after the accident. All other terminals were found to be tight, and were marked in accordance with the wiring diagram.
- The access panel below the port winch control panel (slave) was removed to allow testing of the ERB in the run position. No damage or loose terminals were noted, but the switch test was inconclusive due to water damage.

- The aft winch control panel (slave) was opened up to allow testing of the ERB in the run position. No damage, or loose terminals were noted, but the switch test was inconclusive due to water damage.

5.2 ELECTRICAL TESTS OF THE WINCH EMERGENCY BRAKE RELEASE SYSTEM

Physical examination of the electrical control system was completed, and tests were then undertaken by the electrician:

- The winch control system supply/starter box (located inside the deck workshop) was dry internally and an average insulation reading of 0.8 megohm was obtained. All the terminals were tight.
- Continuity from supply/starter box up to wheelhouse control panel was satisfactory.
- Continuity from the supply/starter box to the winch emergency release hydraulic system solenoid valve at the power pack was satisfactory.
- Electrical insulation on these circuits was checked and found acceptable for further tests. A temporary 24V supply was rigged from batteries and a test signal was sent by operating the ERB on the starboard winch control panel in the wheelhouse. It was found that the emergency release hydraulic system solenoid coil (mounted on top of the power pack) operated. However, while the solenoid operated electrically, the mechanical part of the valve (which was normally operated by the solenoid) did not operate. This meant that it was not possible to fully complete the test process as planned, by initiating a remote release of the brake from the wheelhouse console, (but see 5.4.3).
- Both main electric motors on the winch hydraulic power pack pumps were insulation tested and found to have been damaged by immersion; they were not safe to run and were not further tested.

5.3 HAND OPERATED WINCH BRAKE PUMP

In order to test the hand pump, the emergency brake override valve was rotated to the hand pump position. The cock was difficult to operate, but functional. The hand pump was tested by the winch engineers and the hydraulics engineer, and it opened the winch brake band satisfactorily, albeit very slowly. This test also served to prove mechanical operation of the winch brake assembly.

5.4 HYDRAULIC ACCUMULATOR AND ACCUMULATOR PUMP

- Hydraulic accumulator

The hydraulics engineer examined and then tested the accumulator as an individual component; having removed the valve protection cap fitted to the top of the accumulator and fitted a new test gauge, the bladder pressure was seen to be 50 Bar, this is in accordance with manufacturers' recommendations. The accumulator was found to be undamaged and in an operational condition.

- Hydraulic accumulator pump

In order to test the accumulator pump, a temporary air supply was connected in place of the usual ship's supply. The accumulator pump was operated and the engineer confirmed that it charged the hydraulic accumulator satisfactorily.

- Emergency release hydraulic system solenoid operated valve

While the valve did not appear to be operational, the valve was found to be stuck in the "energised" position, indicating that it had operated. The hydraulic engineer tested it manually and the valve operated normally (in manual mode) during subsequent tests.

5.5 STATIC BRAKE OPERATION TEST

Satisfactory operation of the accumulator and brake actuator systems having been confirmed, the next step was to test the brake operation using the accumulated hydraulic pressure, with the winch drum static. The accumulator was charged by the accumulator pump. By then using the override to manually operate the solenoid valve, it was possible to demonstrate that the air pump/hydraulic accumulator arrangement was functional, and released the towing winch brake satisfactorily.

5.6 TOWING WINCH TEST RUN - OFFLOAD

As a result of the generally positive findings of the investigation at this point, attending investigators and specialists agreed that the best way forward would be to attempt to run the towing winch in order to be able to see it operate and more fully explore its condition and remaining capabilities. This approach had the additional benefit of minimising intrusive disturbance of evidence.

In order to run the winch under power, a portable hydraulic power pack was rigged to provide a temporary oil pressure supply, by tapping into the system near the power pack in the deck store. In order to minimise the possibility of damage to the portable power pack, the oil return from the winch hydraulic system was initially lead to the tug's bilge, so as to flush through the system with clean oil. It was then possible to connect

the temporary hydraulic oil return line to the power pack ready to begin the tests.

With the temporary electrical, air and hydraulic oil pressure supplies connected into the onboard systems, it was then possible to “drive” the winch using the operating control on deck, at the winch side.

The loose end of the tow rope was carefully secured back on to the winch drum, and the winch was then successfully operated in free-running mode, in both heave and veer directions. This allowed an examination by all of the attending specialists and investigators of the drum, bearings, gears and hydraulic motor, together with an offload dynamic test of the brake system. No significant defects were found and the winch appeared to operate satisfactorily.

It was noted that the displaced brake band tended to re-centre itself, back to its normal operating position (as indicated by the witness marks on the brake drum) to some degree during these tests; however it did not quite fully recover its original position. This could indicate some small degree of distortion of the brake mechanism, but the attending experts did not believe this to be significant.

5.7 THE TUG END OF THE TOW ROPE

- Evidence recovery

Care to preserve evidence was taken during the removal of the tow rope from the tow winch drum. The operation was at all times witnessed by the Strathclyde Police Officers, and the attending MAIB investigator.

Due to the way in which the tow rope had been spooled on to the winch drum, it was estimated that approximately three layers of tow rope remained; this would be adequate to secure the tow rope to the drum.

All of the tow rope in use at the time of the accident, that remained on board *Flying Phantom*, was recovered as evidence. The rope was recovered into a new “bulk bag” (a large square canvas sack of the type used by builders’ merchants) so as to minimise damage.

The free - length was marked (using electrical tape) so as to indicate the point at which it became necessary to “break out” the rope from the coils remaining on the drum. With the winch operated under power, the rope was easily removed from the drum and taken off directly in to the bulk bag.

The tow rope was disconnected from the winch, and the complete item was secured in the bulk bag; the bag was then craned on to the quay. The recovered rope remained under police custody at all times. The

MAIB inspector assisted the police with loading the evidence in to a transit van, for delivery to the test house.

- Tow rope attachment to the winch

The end of the tow rope was found to be attached to the winch drum by means of a short length of light rope, secured through an eye formed on the tug end of the tow rope.

This arrangement is normal, and is intended to ensure that the tow rope readily breaks free from the winch, so releasing the tug from its tow, once all of the tow rope has been pulled off the winch (**Figure 8**).

5.8 TOWING WINCH TEST RUNS – ONLOAD

With the original tow rope removed and secured as evidence, a spare tow rope was spooled on to the winch drum in order to enable further tests of the winch. This rope provided approximately three layers of rope on the winch drum.

- Rigging for winch function test

The tow rope was rigged from the winch to a strong point on the after deck; a calibrated, remote reading load cell was connected between the tow rope and the strong point. The load cell allowed a direct reading (at a safe distance) of the pulling force applied to the tow rope by the winch.

- Winch pulling test

The winch was operated under power; the load cell showed that it was not capable of developing more than about 3 tonnes direct maximum pull as configured. The winch specification data provided by owners confirms that this finding was reasonable, indicating that the winch was generally operating as expected.

- Brake function test

With the load applied to the tow rope by the winch itself, the brake system operated correctly, but appeared to operate and release the load more slowly as increasing load was applied. It was seen that the brake band did not open evenly around the full circumference of the brake drum, and the brake operating ram was almost at the limit of its travel before the brake released the load on the winch. During tests at an applied load of 3.5 tonnes, the winch brake took 6 to 8 seconds to release; its operation was slow and steady, with no sudden movements of the rope as the load was removed.

The brake function was also tested by applying a load to the static tow rope, using an external pulling device. The intention was to better simulate release of a load under conditions more closely related to

those prevailing at the time of the accident. This test produced results very similar to those detailed above.

- Hand operated emergency pump

Load was applied to the tow rope as above; release was then initiated using the hand pump only. Operation of the hand operated winch brake pump became more difficult as the load on the tow rope was increased, but it was possible to release the brake by this method.

SECTION 6 FINDINGS AND CONCLUSIONS

6.1 WINCH CONTROL SYSTEM

It was remarkable that this system was still substantially functional after a month submerged in the River Clyde. Although it was not possible to completely replicate an emergency release from the wheelhouse, it was possible to confirm that the control system operated at the power pack electrical/hydraulic interface. It was also then possible to release the winch brake mechanism, by manually operating the solenoid valve. This valve continued to operate normally when manually activated during subsequent tests.

The tests conducted by the attending specialists and witnessed by investigators produced no evidence that there was a pre-existing fault in the towing winch brake release remote control system.

No evidence was found that when the EBR was operated from the starboard wheelhouse control panel it did not operate and release the towing winch brake.

6.2 HAND OPERATED WINCH BRAKE PUMP

Due to the need to first go out on to the aft deck of the tug to change over the brake override cock, then to access the hand pump unit inside the far reaches of the deck store, and finally its slow rate of operation (particularly when operated under load), the hand operated pump does not realistically form a part of any emergency release system.

6.3 OVERALL CONCLUSIONS

- No evidence was found that there was any pre-existing fault in the emergency brake release system, or in the operation of the mechanical parts of the winch brake system. The examination and test results detailed above suggest that it was very likely that the winch brake was released by the action of pushing the ERB on the starboard side wheelhouse console.
- The winch brake band was found displaced towards the port side of the tug, (coinciding with the orientation of the tug, as it capsized, and lay on the bottom of the River Clyde). This evidence suggests that the

brake band was open at some time when the tug was lying on its port side. As the hydraulic operating pressure in the brake operating system then dissipated over time, the brake band was closed by the springs, leaving the brake band displaced from its normal operating position due to the influence of gravity upon the brake band and the linkage arrangement. This evidence confirms that the brake band did release at some point during the accident.

- During tests at relatively low applied loads, *Flying Phantom's* emergency brake release system, while operational, did not operate as a "quick release system", whereby a release command would result in the immediate and instantaneous release of the load on the towing winch.

Figure 1a

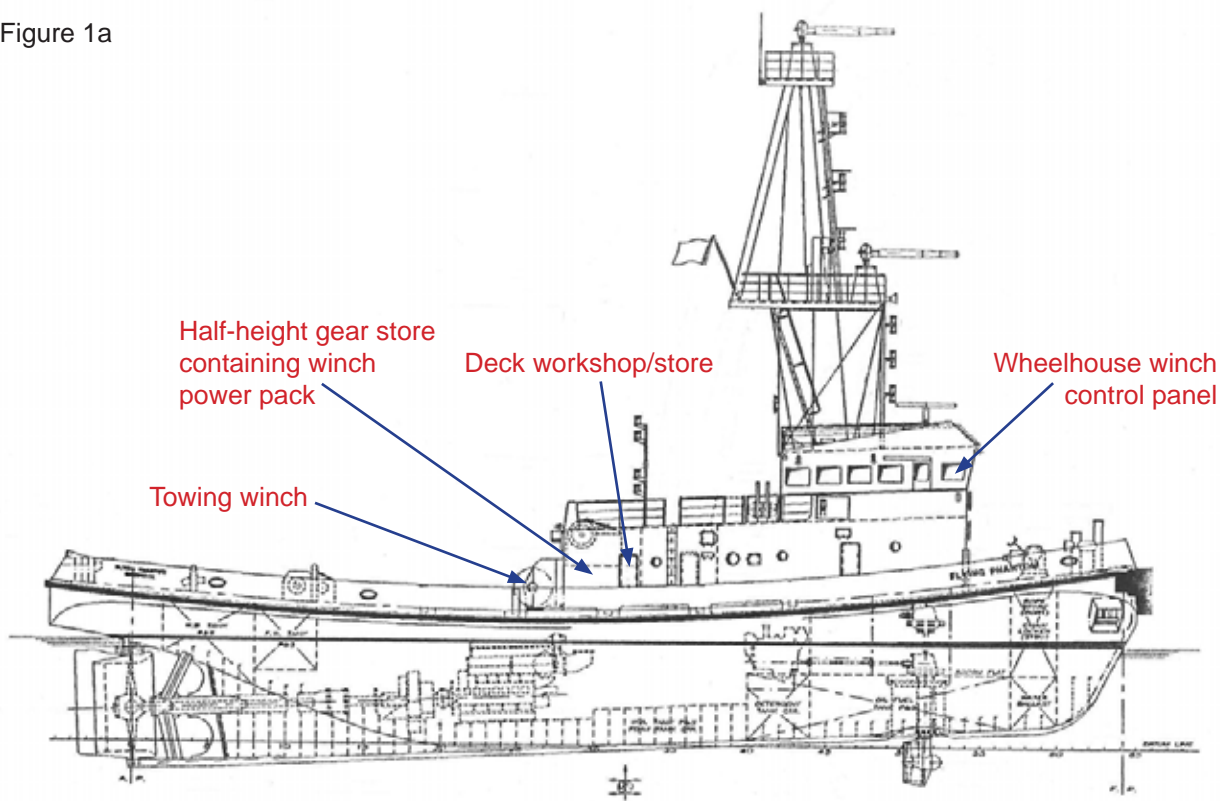

Figure 1a

Figure 1b

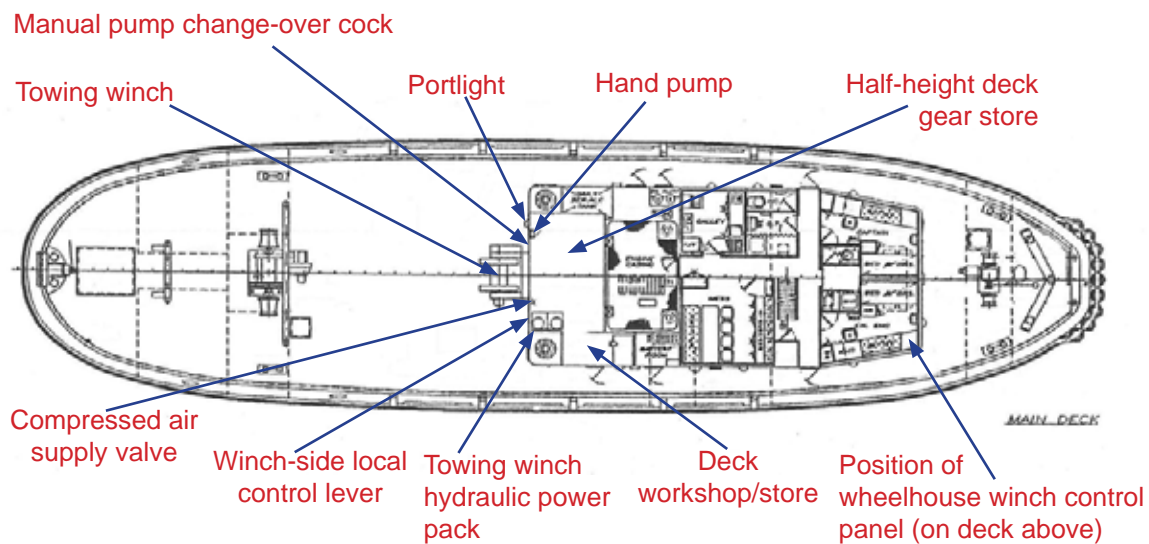

Figure 2



Figure 3



Figure 4

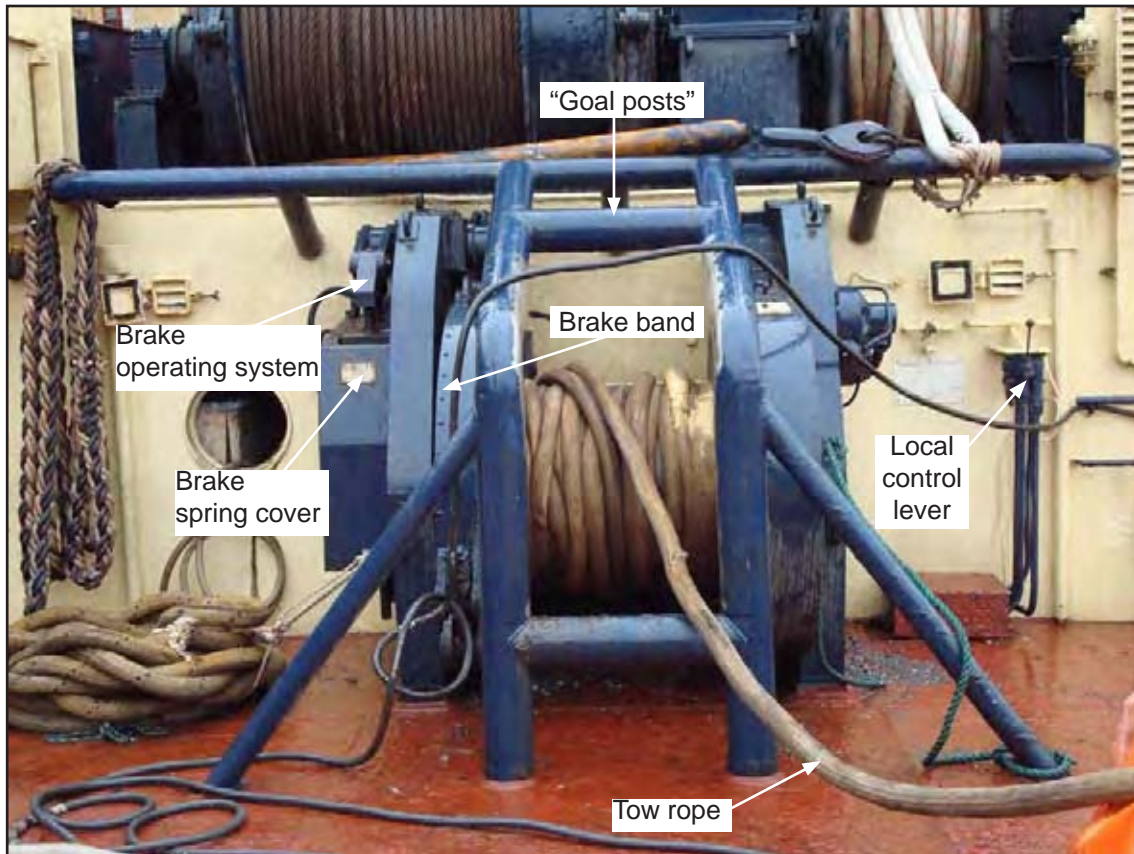

Figure 5



Figure 6



Figure 7

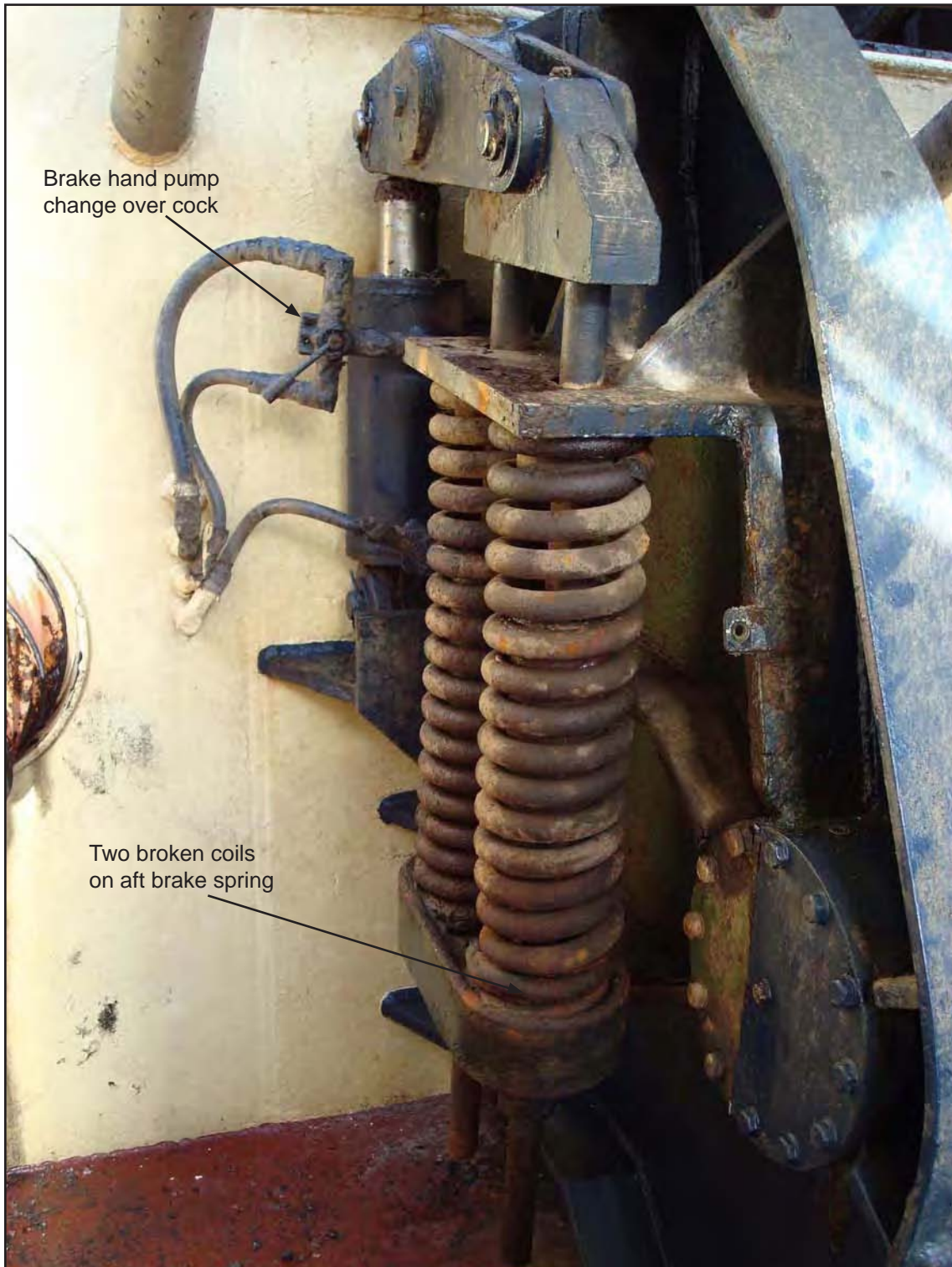

Figure 8



CONTENTS

OPERATION OF THE WINCH

HYDRAULIC SYSTEM

EMERGENCY RELEASE

CONTROLS

TECHNICAL SPECIFICATION

INSTALLATION AND COMMISSIONING

HYDRAULIC CIRCUIT

PARTS LIST

POWER PACK

CONTROL PANEL

HYDRAULIC COMPONENTS

ELECTRICAL DESCRIPTION

CONTROL PANEL CIRCUIT

STARTER PANEL CIRCUIT

JOY STICK CONTROLS.

OPERATION OF THE WINCH

The Winch can be operated either locally by means of a manual lever or remotely by any one of three electrical Joy Sticks.

From all positions the speed of the winch can be controlled proportionally by how far the lever is moved. On operating the control the spring held on brake is released by a Hydraulic Cylinder.

The Hydraulic Motor has a constant power control which enables its displacement to change in proportion to outboard load. i.e. when the Winch is running light the Hydraulic Motor will be in its minimum displacement and the Winch will run at its maximum speed, as the load on the Winch increased the speed will automatically decrease enabling the Winch to pull to its maximum load. As the load decreases the Winch will speed up. This facility maximises the power available at all times and enables stepless control.

DESCRIPTION : HYDRAULIC SYSTEM.

The Hydraulic Power Pack consists of two fixed displacement bent axis piston pumps. The pumps are driven by electric motors. Both Pumps are required to achieve maximum specified speeds.

The System pressure is set by relief valves mounted on the reservoir. The two pumps are piped together to give a single pressure supply. The system is open circuit and the oil is circulated through the directional control valve and back to the reservoir via a return line filter.

On operating the directional control valve the oil is diverted to the Hydraulic Motor. This is via a motion control valve, the oil passes through the motor and back through the motion control valve, D.C. V. and back to the reservoir.

A small amount of oil is taken off at the motion control valve and releases the Winch Brake.

EMERGENCY RELEASE HYDRAULIC SYSTEM.

The emergency release system is to enable a load outboard of the ship to pull wire off the drum without doing any damage to the Hydraulic Motor and enabling control of the winch to be available when required.

The system consists of an Accumulator which is charged up by the main Hydraulic Pumps and an Air Driven Pump.

On operating the emergency release system the brake is released from the Winch. The Hydraulic Motor is put into its lowest displacement, the motor ports are connected together and a boost supply is fed to the motor.

The oil for this operation is fed from the accumulator on sensing, decreasing pressure in the accumulator, the air driven pump will start recharging the accumulator enabling repetitive operation. The pressure of the air pump is set by an air pressure regulator.

CONTROLS

The Hydraulic Power Pack can be started and stopped locally at the starter panels or remotely in the bridge on the main bridge control panel. There is a control on button, this puts power supply to the panel to allow operation and also resets the Joy stick control each time it is selected.

The low oil pressure light indicates the pressure of the oil in the accumulator. If this light remains on there is a problem with the emergency release system.

The emergency release button enables an outboard load to pull rope off the drum and release any load on the winch. On pulling the button back out the winch will once again hold the outboard load.

There is a manual emergency release lever situated on the winch which enables the same operation.

TECHNICAL SPECIFICATION

Pump Delivery	2 x 40 L/Min
Max Pressure	220 BAR
Accumulator Max pressure	220 BAR
Pre charge pressure	34 BAR
Air Pump Pressure 7 BAR AIR	210 BAR
Air Pump Pressure 5 BAR AIR	150 BAR
Accumulator capacity	10 L
Required Air Inlet Pressure	5 BAR
Oil	ISO32
Max Oil Temp.	80 DEG C
Return Filter	10 MICRON
Suction Filter	125 MICRON
Electric Motors	2 x 18.5Kw. 415V. 3Ph.50Hz.
Direction looking at fan	CLOCKWISE
Motor Speed	1500 RPM
Drum Speed at 2000Kg	16 RPM
Drum Speed at 5000Kg	8 RPM
Drum Speed High Displacement	9.73 RPM
Drum Speed Minimum Displacement	16 RPM
Pull on Bottom Layer	5 TONNE

HYDRAULIC INSTALLATION

The hydraulic installation is to be carried out by Armstrong Hydraulic Services own fitters and will be to our quality standard guidelines.

KEY POINTS

Care is to be taken to prevent any contamination entering the system during the installation.

All Fittings where possible to be JIC 37deg Flare or BSP Threads.

All Tube above deck to be stainless steel seamless 316

All Tube below deck to be Carbon Steel to BS.3602 DIN2391/C

The Hydraulic pipe installation is as the Hydraulic Circuit Diagram.

Commissioning to be carried out under the guidelines of Armstrong Hydraulic Services Quality Standard.

On completion of the installation the Hydraulic Reservoir should be filled with oil.

Check pipe installation is correct, the pipes to the Hydraulic Motor should be looped out by connecting in the Test Meter.

Put air onto Air Pump, set air pressure , charge accumulator to pressure, air pump will stop when pressure is reached.

Check for Leaks.

Operate Emergency Release System. Brake should release Set pressure for boosting motor A & B Lines.

Air Pump should cut in and recharge accumulator.

Switch supply on to control panel. Operate Joy Stick in Bridge.

Lever on D.C.V. should move, check direction.

The Hydraulic Pumps may now be started, recommend use local buttons in panels.

On starting the Hydraulic Pumps check:

Direction of rotation.

Leaking Connections

Pressure should be minimal.

On operating the D.C.V. the System flow should be seen at the test meter.

On closing the Test Meter the max. system pressure should be achieved.

Pump relief valves are pre set. The Accumulator will charge and maintain pressure. Check leaking connections as pressure is increased.

While these initial tests are carried out the oil will be circulating.

Check filter indicator, replace if required.

Check Brake is released when D.C.V. is operated

Check brake goes on when D.C.V. is in neutral position.

When pressure is satisfactory and installation is correct, reconnect Hydraulic Motor.

Check constant power manual override valve is mounted on winch motor.

Winch may now be rotated.

Check Speeds with valves in all three positions.

Check Directions are correct.

Check Brake operation is correct.

Check pressure is not too high for light running.

Operate Emergency Release, check reduced pressure and brake operates.

At this point for any further commissioning a Load Cell is required and the vessel must have a load to check the winch heave capacity.

2 X 18.5KW 80L/MIN 220 BAR POWER PACK

ITAM	DESCRIPTION	PART NO.	QTY
1	ELEC MOTOR 18.5KW	DA180MAD + HEATER	2
2	PUMP	HIC030CFP1D	2
3	BELL	B35F25/025/045	2
4	DRIVE COUPLING	S 42/55/48/25X45-D	2
5	RELIEF VALVE	1AR66P4W40S	2
6	ACCESS COVER	LEC18	2
7	LEVEL GLASS	LG5T	1
8	SUCTION FILTER	LSE75	2
9	RETURN FILTER	TT30BAGV	1
10	PRESSURE GAUGE	LPL63-400S	3
11	CHECK VALVES	CV6A-05	2
12	RESERVOIR 150L	1100X600X500	1
13	DCV	F130-CF	1
14	SUCTION FILTER	LSE25	1
15	INTENSIFIER	UH4B-30	1
16	CHECK VALVE	CV4A-05	1
17	AIR REGULATOR	20AGX4G	1
18	BALL VALV	BV16B	1
19	MOTION CONTROL	1CEEC SH150F6W35S4	1
20	PILOT OP CHECK	4CK125-2W6WS	2
21	PRESSURE REDUCER	1PA66P4W35S	1
22	MANUAL RELEASE	DH5-3A	1
23	FLOW VALVE	FCV12B	1
24	NEEDLE VALVE	NV12B	1
25	ELECTRIC RELEASE	WE06DA08A0240	1
26	BRAKE VALVE	1SB252P3W6S377	1
27	CETOP 3 SUBPLATE	AG6S	1
28	SHUTTEL VALVE	WVT12S	1
29	ACCUMULATOR	BA34510A0B0CC6D0E	1
30	ACC SUPPORT	HSS222/229	1
31	ACC SUPPORT	KBK222/G	1
32	LOW DISPLACEMENT	0610600/02212/102000	1
33	JOY STICK	ICS416	1
34	FLOW VALVE	FCV04B	1
35	MOTOR	HMC080S FM3185	1
36	BRAKE CYLINDER		1
37	HAND PUMP	OMPM45LVSS5	1
38	BALL VALVE	DH53A	2
39	PRESSURE SWITCH	DS302-150	1

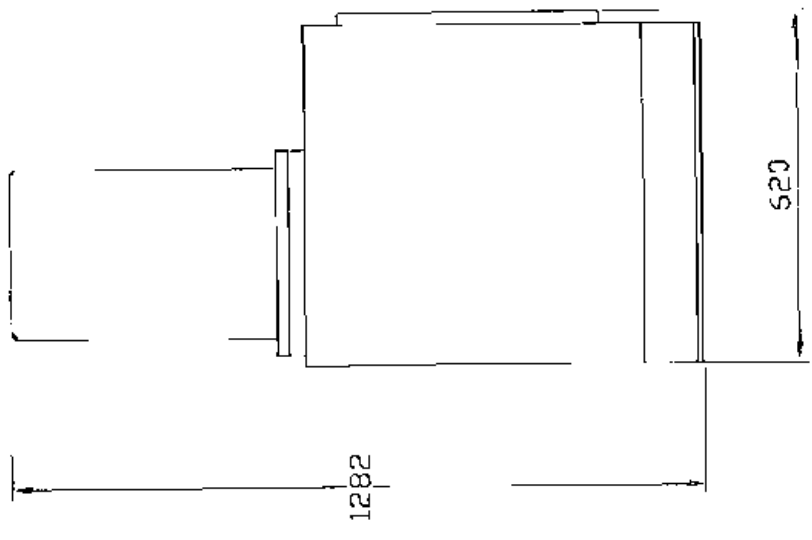

APPROXIMATE MASS
INCLUDING OIL
1000KG

ARMSTRONG HYDRAULIC SERVICES (HULL) LTD.	
TITLE	TWO X 18.5KW HYDRAULIC POWER PACK
DRGNO	2875C
DATE	10.10.1997
DRG.	B.ARM

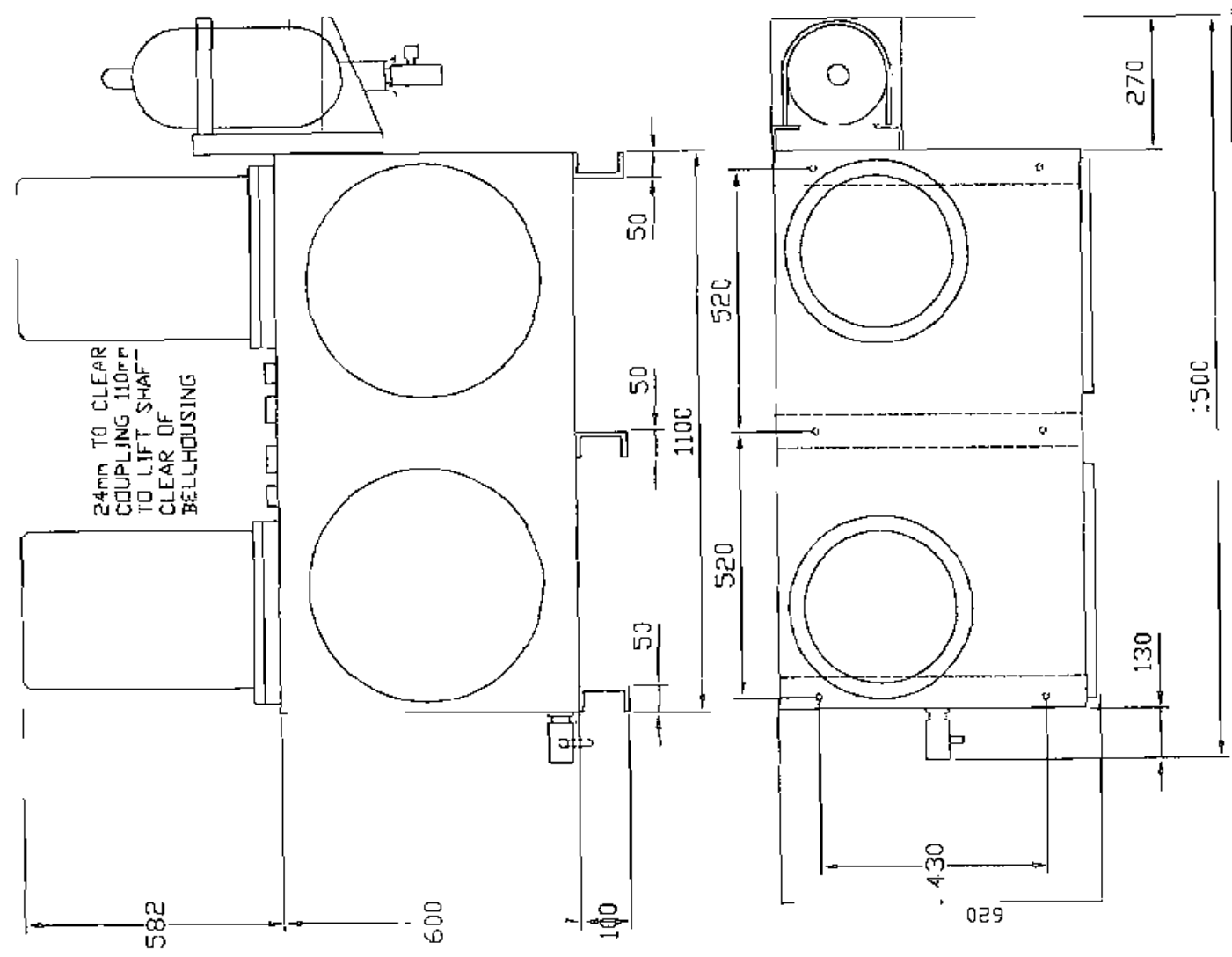

HYDRAULIC COMPONENTS

Hydraulic Motor

D.C.V.

Accumulator

Pump

Relief Valve

Brake Sequence Valve

Motion Control Valve

P.O. Check Valve

Pressure Reducing Valve

Manual Brake Release

Return Filter

Suction Filter

Check Valve.

Hand pump

Air oil intensifier

Staffa® HMC080 Dual Displacement Hydraulic Motor

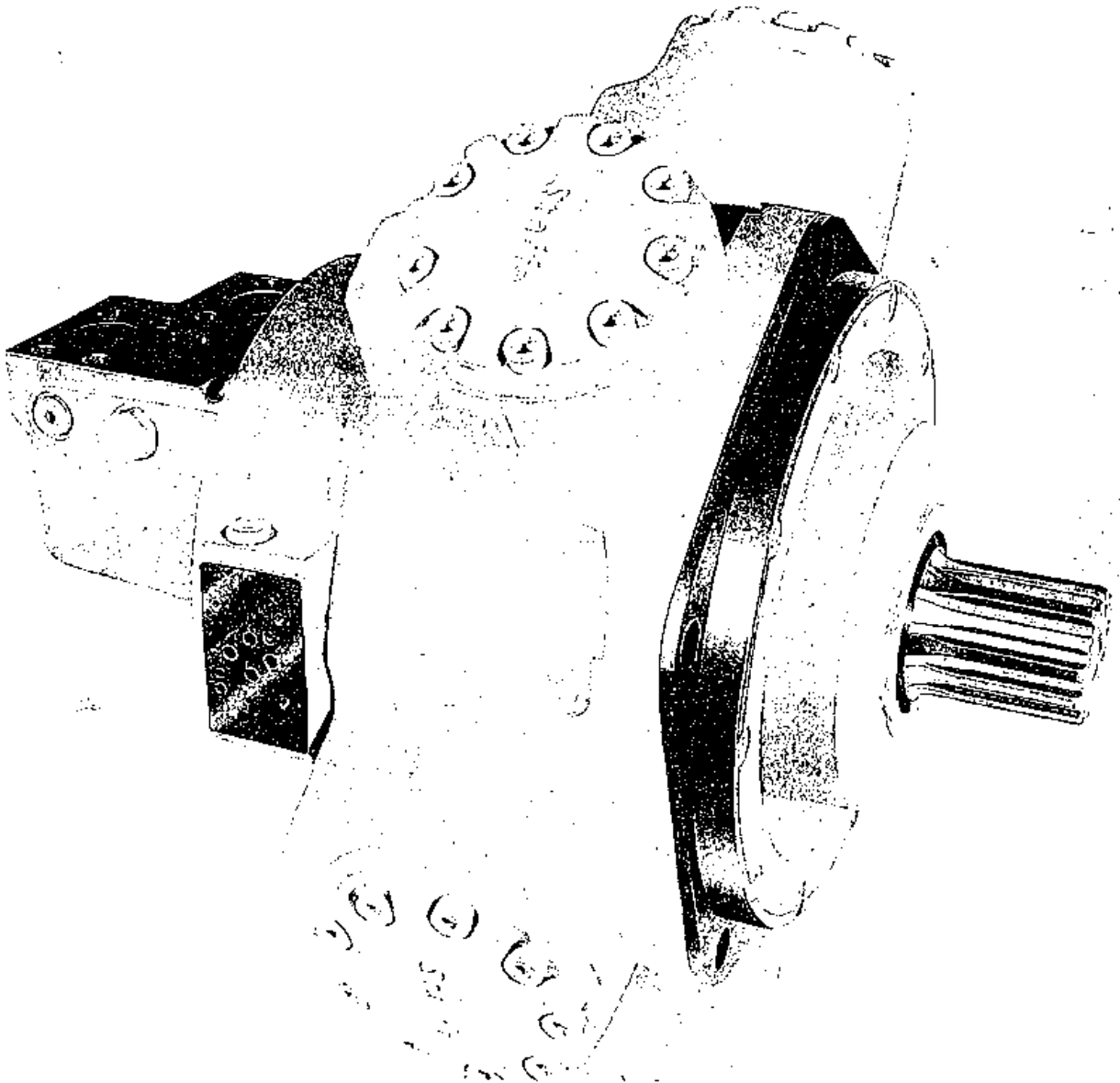

Contents Page

1. General Description.....	2
2. Functional Symbols	2
Model Code	3
4. Performance Data:	
Motor selection	3
Rating definitions	4
Output torques	5
Bearing life	6
Volumetric efficiency	6
5. Circuit and Application Notes:	
Displacement selection	7
Starting torques	7
Low speed operation	7
Small displacements	7
High back pressure	7
Boost pressure	7
Cooling flow	8
Motor casing pressure	8
6. Hydraulic Fluids	8
7. Temperature Limits	8
8. Filtration	8
9. Noise Levels	8
10. Polar Moment of Inertia	8
11. Mass	8
12. Installation Data:	
General	8
Motor axis horizontal	8
Motor axis upwards	8
Motor axis downwards	8
Start-up	8
13. Installation Dimensions ...	8 to 11

1. General Description

Kawasaki "Staffa" high torque, low speed radial piston motors use hydrostatic balancing techniques to achieve high efficiency, combined with good break-out torque and smooth running capability.

The HMC series dual displacement models have two pre-set displacements which can be chosen from a wide range to suit specific application requirements. The displacements are hydraulically selected by a directional control valve which can be remote from, or mounted directly on, the motor. Displacements can be changed when the motor is running.

The range of HMC motors extends from the HMC010 of 202 cm³ (12.3 in³) to the HMC325 of 5330 cm³ (325 in³) displacement.

These motors are also available in a continuously variable version using either hydro-mechanical or electro-hydraulic control methods.

Other mounting options are available on request to match many of the competitor interfaces.

The HMC080 is one of 8 frame sizes and is capable of developing torques up to 6050 Nm (4460 lbf ft) with a continuous output power of 112 kW (150 hp).

The Kawasaki range also includes fixed displacement motors, plus matching brakes and gearboxes to extend the torque range

2. Functional Symbols

All model types with variants in model code positions 6 & 7.

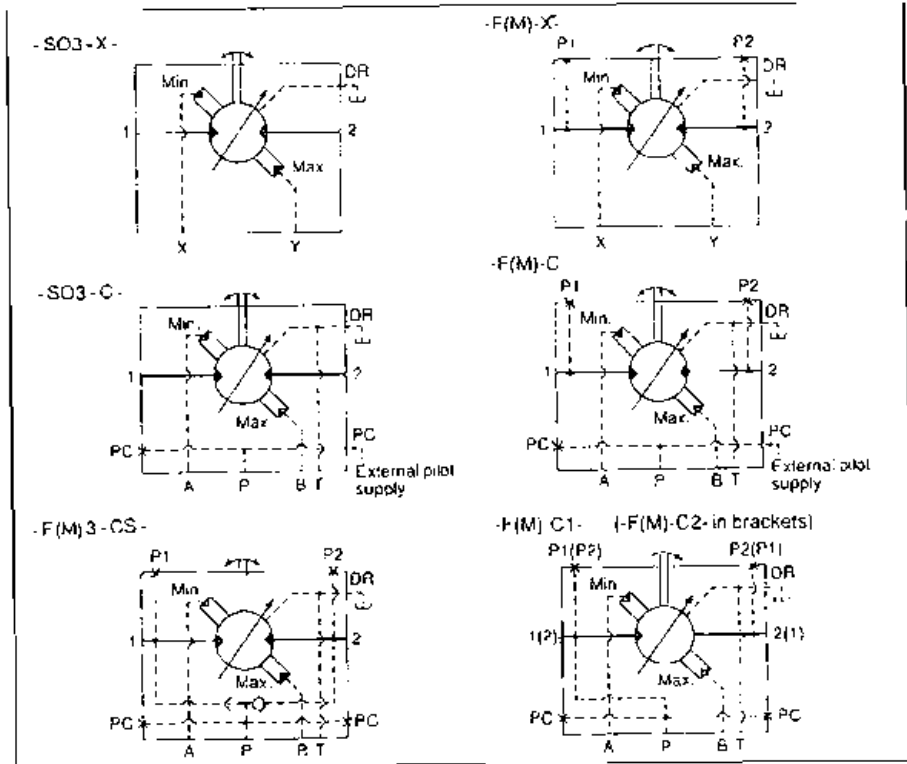

VICKERS

Staffa® Constant Power Hydraulic Motors

HMC***---CP**, 30 Series
HMC***---CHP**, 30 Series

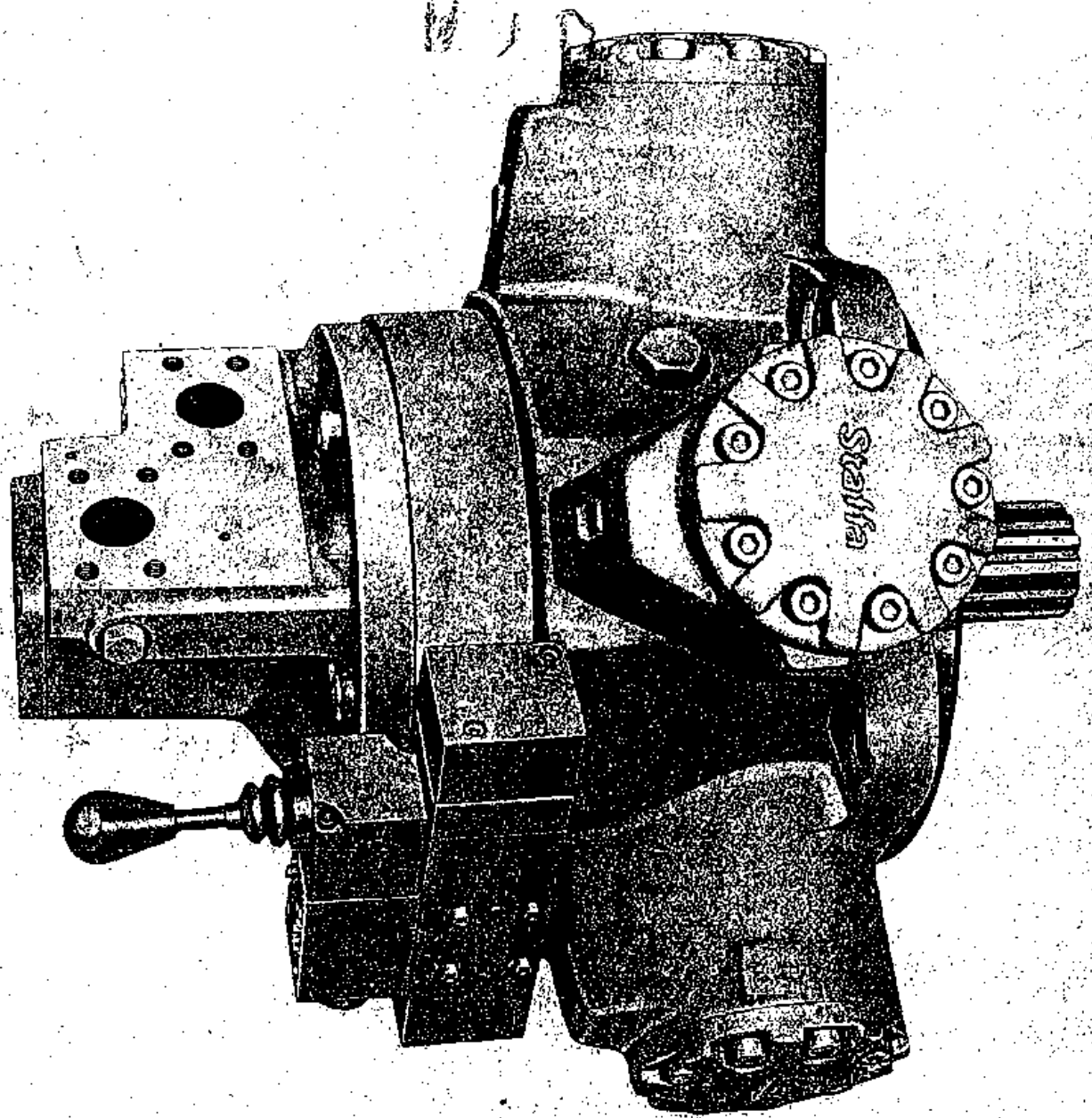

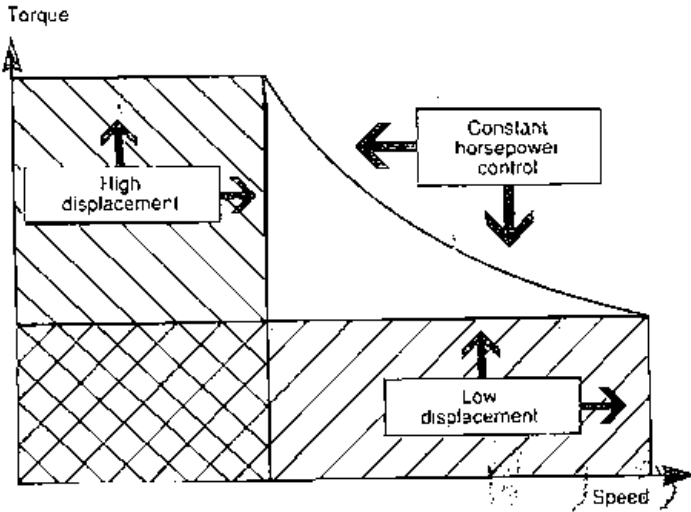

lubrication and anti-scuffing features to ensure long, trouble free life under continuous displacement control. *Standard HMC dual displacement motors do not have or require these enhanced features, and should not be used with CP or CHP control.*

This catalog features motors for bi-directional drive applications. Motors for uni-directional drive applications are also available: consult Vickers.

Features and Benefits

- High operating efficiency
- Reduction in process times
- No field adjustments necessary
- Robust construction for arduous environments

1. Introduction

These Constant Power motors are developed from the well-proven range of Staffa HMC series dual displacement motors, in sizes 030, 045, 080, 125, 200, 270 and 325.

Whereas the dual displacement motor operates only at either maximum or minimum displacement, the constant power motor control system continuously adjusts the motor displacement within the selected displacement range so as to keep the hydraulic inlet pressure constant. The torque/speed "gap" of the dual displacement motor is thereby eliminated, and the field of application of these motors considerably extended.

Staffa HMC constant power motors provide a robust, trouble free package for applications with fixed operating parameters and arduous operating environments, e.g. conveyors, track drives, fishing trawler winches, etc., where optimum use of available power is required.

For applications where a more flexible system is required, Vickers type CVM electro-hydraulic proportional valve displacement control can be supplied. This versatile system, with appropriate feedback sensing, can be used to control motor displacement, shaft speed, inlet pressure, output torque, etc., or combinations of these parameters. Vickers offers a range of standard electronic control amplifiers plus system engineering expertise to

help in the correct selection, design and start-up of these systems. The CVM control is described in catalog C-2317.

2. General Description

The constant power motor incorporates an hydro-mechanical proportional control valve which senses, and responds to, variations in pressure at the motor inlet port. Changes in inlet pressure from an adjustable, preset value cause the control valve to direct oil to the displacement piston chambers in the motor crankshaft, thereby altering the displacement to maintain the inlet pressure at a constant value. The factory preset pressure of this valve is matched to the specific power requirements of the application.

The control valve is normally motor-mounted. It can alternatively be remotely mounted using an ISO 4401 size 3 subplate. For such applications contact Vickers for advice on connecting control pilot lines to motor.

An optional ISO 4401, size 3, manually operated override valve enables high and low displacements to be selected during setting-up, testing, etc.

The range of high and low displacements and shaft options is as for the HMC series dual displacement motors.

Motors specified with CP or CHP control have enhanced crankshaft

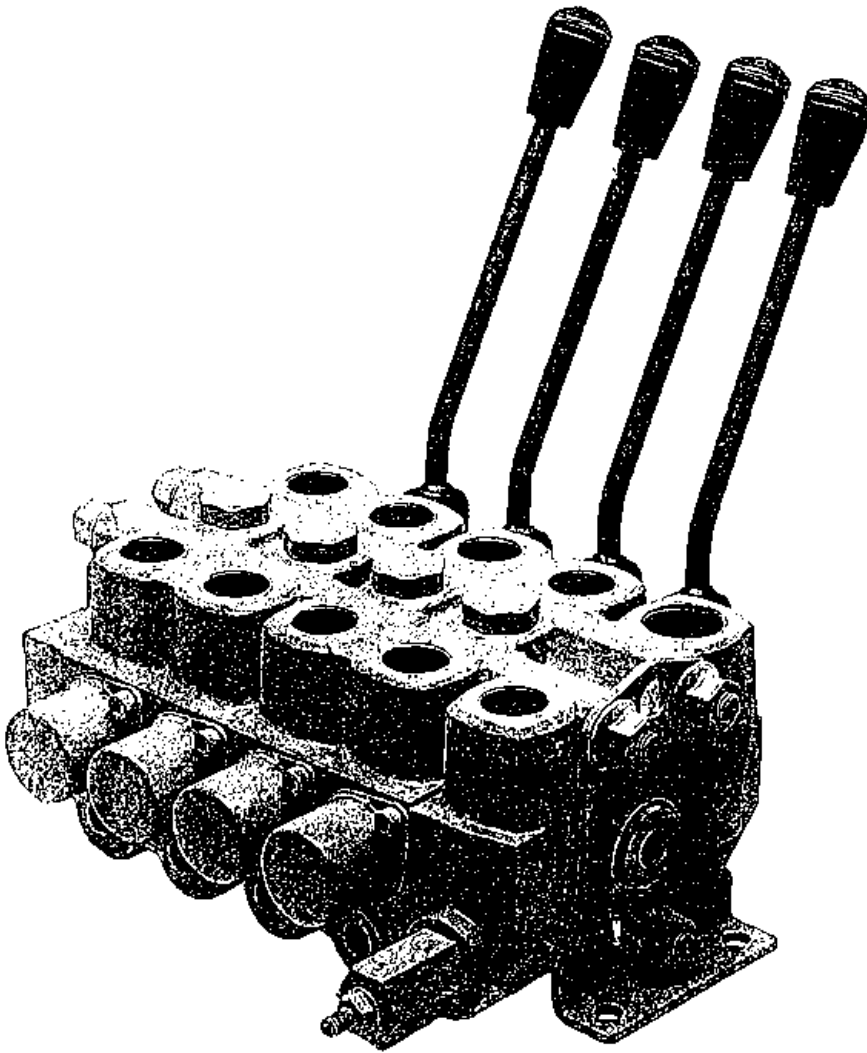

F 130 CF

General

The F130CF is a stackable, open-centre directional control valve, designed for systems that are fed by fixed-displacement pumps (CFO systems). The valve can be equipped with a special bypass block (Q), which reduces the pressure drop when the system is idling, and increases the capacity of the valve. Among the many accessories available for the F130CF is a mid inlet section that enables feeding by two or more pumps, either in separate or combined circuits. The F130CF has many different applications in both mobile and industrial machines, e.g. front-end loaders, cranes, back-hoe loaders, forest machinery and excavators.

The versatility of the valve, together with its wide range of standard accessories, enables the user to optimize hydraulic systems in respect of:

Compact system design

Many optional built-in functions

Flexibility in machine design and construction

Wide range of spool actuators for direct operation and/or remote control, allows flexibility in locating components.

Economy

F130CF valves can be custom-built, using standard modules. This eliminates unnecessary functions, and enables the valve to be modified or extended to suit the exact requirements of the customer.

Design and construction

The F130CF is a stackable valve that can be supplied in combinations of 1 to 10 spool sections, connected in parallel (internally). The different combinations are made up from seven separate modules.

The basic F130CF valve is designed for system pressures of up to 250 bar. It can be fitted with motor-port relief valves with settings of up to 280 bar. The nominal flow range is 40 to 90 l/min without the Q-block, and up to 130 l/min with the Q-block.

The valve can be fitted with spools from three different ranges, to suit different pump capacities. The spools are small in diameter, to give low leakage and low lever forces. They are optimized for pump flows of 60, 80 and 110 l/min. For the highest flow rates, the valve is fitted with a special bypass block (Q), which directs only part of the pump flow through the open centre of the valve. The Q-block can be fitted with a solenoid-operated unloading valve.

System adaptation

The F130CF is designed to give optimised performance in constant-flow systems. A special mid inlet section, for systems fed by two or more pumps, enables the valve block for example to be divided into several separate circuits. It also enables series connection of the blocks before and after the mid inlet. The oil that is not used in the first block is directed to the mid inlet, where it is combined with any oil being fed in through this block.

Technical description

1. Inlet section

This consists of an inlet block with a tank connection and two pump connections. The tank connection and one of the pump connections are located on the same face as the motor ports. The second pump connection, located in the end face of the valve, can be fitted with a special adapter for connecting valves in parallel. The section can be fitted with a common load-hold check valve, and an adjustable main pressure-relief valve that can be factory-set if required.

2. Double spool section

The module contains two spools. Each section can be fitted with separate load-hold check valves. All motor ports can be fitted with combined port-relief and anticavitation valves, or anticavitation valves.

3. Single spool section

Single spool sections are used in certain circumstances, e.g. when a mid inlet section is to be located after an odd number of spools. Accessories as for point 2, above.

4. Combined spool/outlet section

The module contains a spool and an outlet. It is used in combinations where an odd number of spool sections are required. Accessories as for point 2, above.

5. Outlet section

This consists of an end plate with a tank connection. It can be fitted with an adaptor (S) to facilitate connection either in series or in parallel. Alternatively, it can be fitted with a counter-pressure valve that raises the idling pressure.

6. Bypass block (Q)

The bypass block is fitted directly after the inlet block. It increases the maximum flow capacity of the valve from 90 to 130 l/min. The bypass block can be fitted with a solenoid-operated unloading valve.

7. Mid inlet section

This is an inlet block for systems that are fed by two or more pumps. The block can be located anywhere in the valve unit. The tank and pump connections of the block are located in the same face as the motor ports. The mid inlet section is available in several versions: one is intended for completely separate circuits; another for series connection of the blocks before and after the mid inlet section. The series connected block is fitted with a check valve. This prevents oil from the pump that feeds the mid inlet section from being fed into the preceding block. However, oil that is not used in the first block can pass through the check valve, for use in the series connected block.

Characteristic features

- Low lever forces give comfortable operation.
- Flexibility, due to stackable design.
- Can be flanged together with Monsun-Tison Manifold block.
- Can be fitted with accessories for multi-pump systems, as well as multi-valve systems.
- Wide range of spool actuators: direct operation; remote control (both on/off and proportional), with pilot operation using hydraulic, pneumatic, electrohydraulic, or electro-pneumatic options. Most actuators can be operated manually, in emergency.
- Large number of spool designs, for optimization of control characteristics at different flow rates, in different work applications.
- Proportional remote control with pressure compensated spools, which further improves control and reduces interference from simultaneously operated functions.
- Separate load-hold check valve in each spool section, to prevent undesirable load drop at the start of a raising operation.
- High grade materials and precision manufacturing give a quality product with low internal leakage and long service life.

Typical circuit diagram for basic model

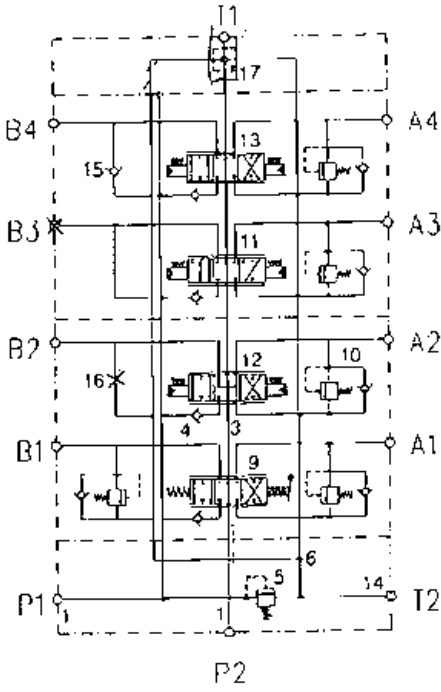

Typical circuit diagram with mid inlet section, series connection

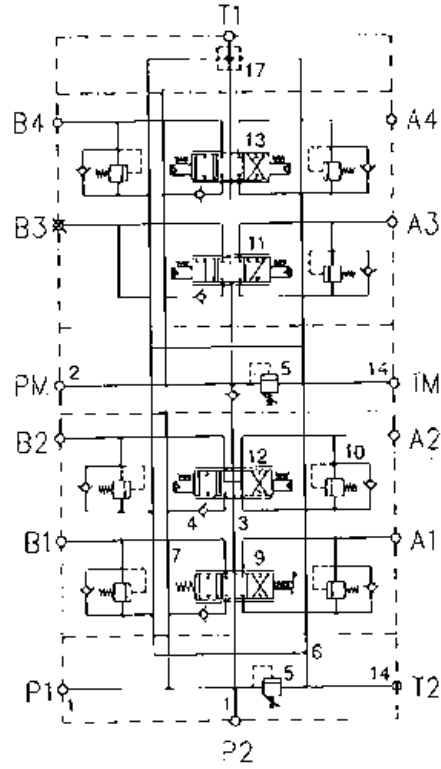

Typical circuit diagram with bypass section

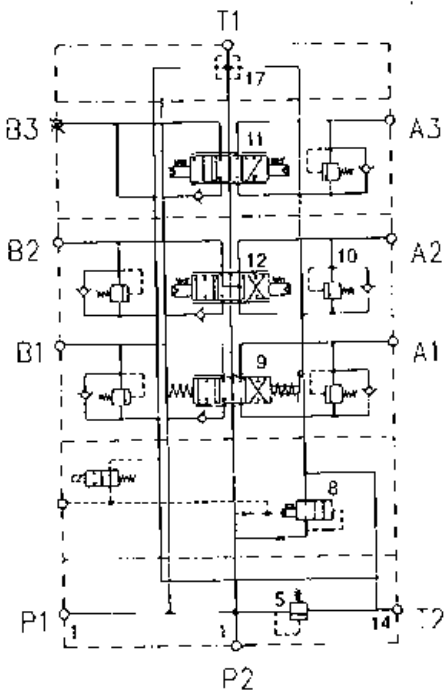

Typical circuit diagram with mid inlet section, 2 separate circuits

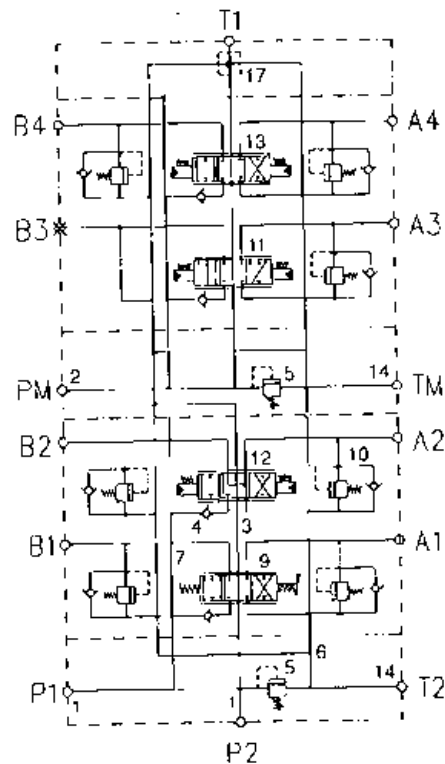

Main relief valve

The main pressure-relief valve is of the direct acting type. It is continuously adjustable, within different spring ranges, up to 250 bar. The valve has excellent operating characteristics, and can be supplied with the pressure setting pre-set and sealed at the factory.

In cases where the Q-block is fitted, external pilot valves can be connected for functions such as pressure relief and unloading.

Alternatively, the main pressure-relief valve can be replaced by a Y-plug that blocks the connection between the pump and the tank.

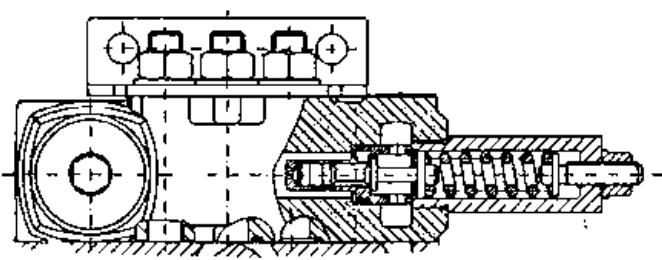

Δp (bar) Pressure relief characteristics

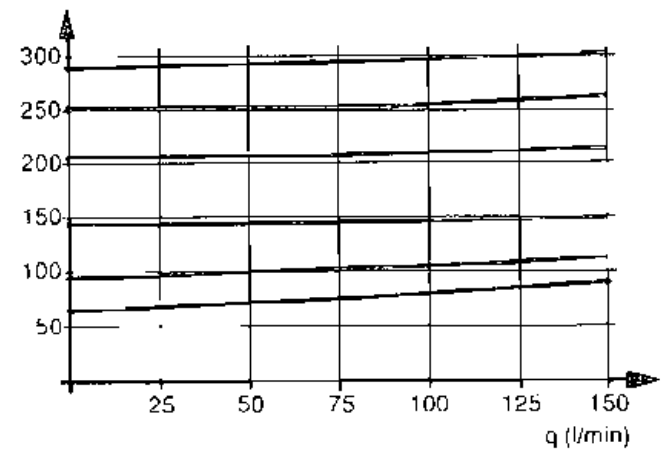

Motor port relief and anti-cavitation valve

The PLC 082 combined relief and anti-cavitation valve is supplied factory-set. It is very fast acting, and has good pressure relief characteristics. Its function as an anti-cavitation valve enables oil to flow from the tank gallery to the motor port, thus preventing cavitation.

Standard settings

Set pressures (bar): 80, 100, 125, 140, 160, 175, 190, 210, 230, 250 and 280.

Set pressures (psi): 1160, 1450, 1815, 2030, 2320, 2540, 2755, 3045, 3335, 3625 and 4060.

Alternatively, the motor ports can be supplied with an anti-cavitation valve only, or with a Y-plug that blocks completely the connection between the tank and the motor port, within the block.

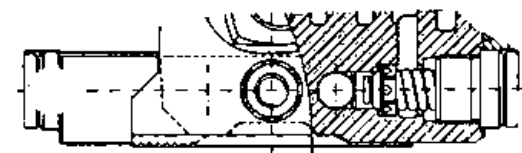

Δp (bar) Motor-port relief valve characteristics

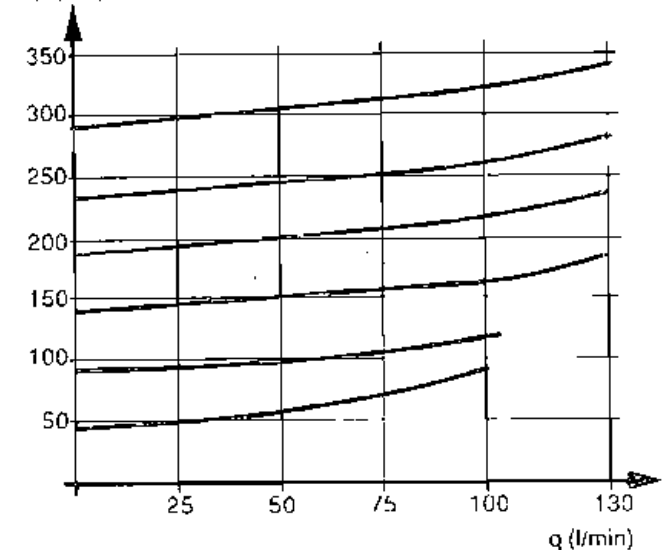

Make up characteristics

Curve 1 shows the pressure drop between the tank connection and the motor port, when the PLC 082 is used as an anti-cavitation valve.

Curve 2 shows the pressure drop between the tank connection and the motor port, when an anti-cavitation valve without a relief valve function is used.

Δp (bar) Anti-cavitation characteristics

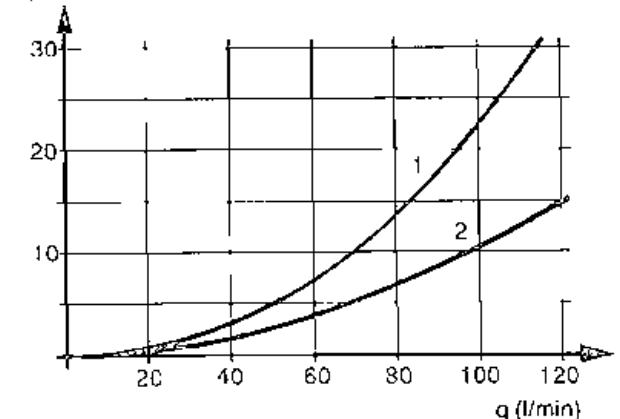

1. DESCRIPTION

1.1. FUNCTION

Fluids are practically incompressible and cannot therefore store pressure energy.

The compressibility of a gas (nitrogen) is utilised in hydro-pneumatic accumulators for storing fluids. HYDAC bladder accumulators are based on this principle, using nitrogen as the compressible medium.

The bladder accumulator consists of a fluid section and a gas section with the bladder acting as a gas-proof screen. The fluid around the bladder is connected with the hydraulic circuit, so that the bladder accumulator draws in fluid when pressure increases and the gas is compressed. When the pressure drops, the compressed gas expands and forces the stored fluid into the circuit.

1.2. CONSTRUCTION

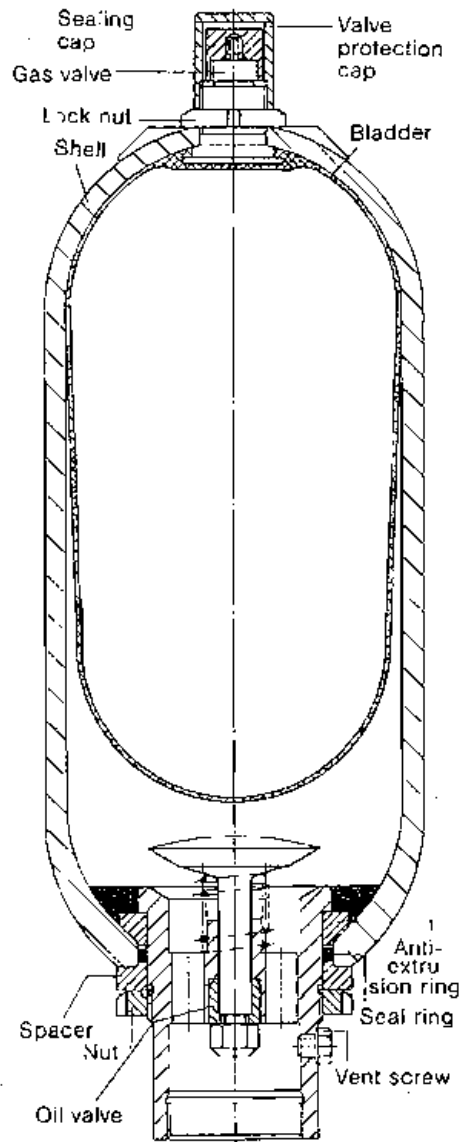

1.2.1. Construction

HYDAC bladder accumulators consist of a welded or forged pressure vessel, an accumulator bladder and valves for gas and oil inlet. The gas and oil sides are separated by the bladder.

1.2.2. Bladder Materials

The following elastomers are available as standard:

- NBR (acrylonitrile butadiene rubber, Perbunan)
- I.R (butyl rubber)
- FPM (fluoro rubber, Viton)
- ECO (ethylene oxide epichlorohydrin rubber)

These depend on the respective operating medium and temperature.

1.2.3. Corrosion Protection

For use with chemically aggressive media the accumulator shell can be supplied with corrosion protection, such as plastic coating on the inside or chemical nickel plating. If this is insufficient, then nearly all types can also be supplied in stainless steel.

1.3. MOUNTING POSITION

HYDAC bladder accumulators can be installed vertically, horizontally and at a slant. When installing vertically or at a slant, the oil valve must be at the bottom. On certain applications listed below, particular positions are preferable:

- energy storage: vertical
 - pulsation damping: any position from horizontal to vertical
 - maintaining constant pressure: any position from horizontal to vertical
 - volume compensation: vertical
- If the mounting position is horizontal or at a slant the effective volume and the maximal permissible fluid flow rate is reduced.

1.4. TYPE OF MOUNTING

- By using an appropriate adaptor, HYDAC accumulators, up to size 1 l, can be mounted directly inline
- For strong vibrations and volumes above 1 l, we recommend the use of our accumulator supports or accumulator mounting set. (Brochure "Accumulator Supports" no. 3.502 ...)



1SB202 BRAKE SEQUENCE VALVE

PILOT OPERATED SPOOL

1SB202

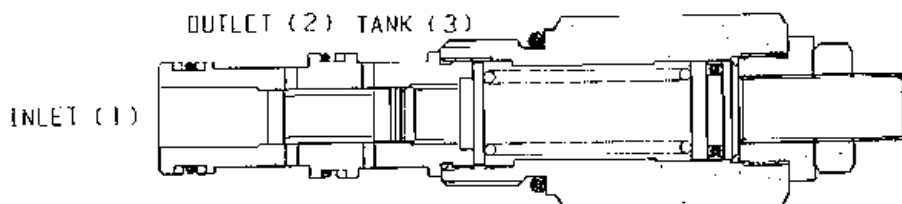
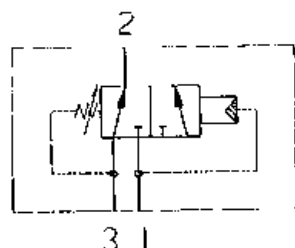

APPLICATION

This valve provides a means of supplying oil to the outlet from the inlet when a pre-set pressure is reached. On removal of this pressure, inlet closes opening outlet to tank. Ideal for use in braking systems where a pressure is required in the main system before the brake is removed.

OPERATION

When pressure in the inlet exceeds the set pressure, flow is allowed from inlet to outlet closing off the tank line. When the inlet pressure is removed, the spool returns to its normal position, opening the outlet port to tank and closing the inlet port.

PRESSURE DROP

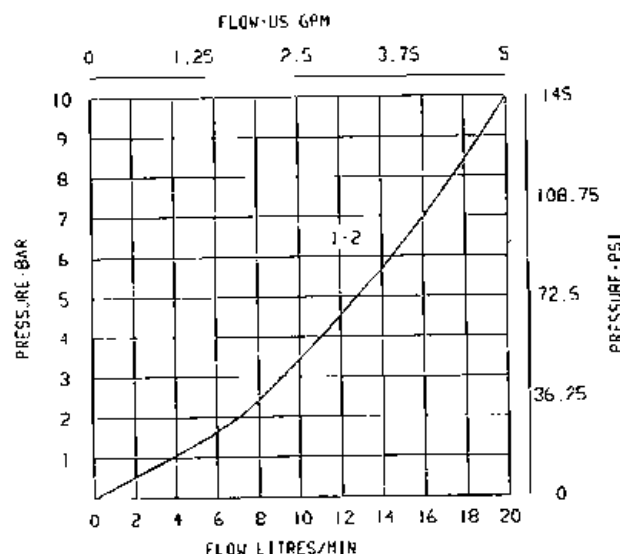

FEATURES

Cartridge design enabling speedy servicing when mounted in a body or in a composite manifold.

SPECIFICATIONS

Figures based on: Oil Temp 40°C Viscosity - 40 cSt

Rated Flow	20 litres/min (5 US GPM)	
Max Pressure	350 bar (5000 psi)	
Pilot Pressure	15 to 140 bar (217 to 2000 psi)	
Cartridge Material	Working parts hardened and ground steel. External surfaces electroless nickel plated	
Body Material	Standard aluminium Add suffix '377' for steel option	
Mounting Position	Unrestricted	
Cavity Number	A5572 (See Section 17)	
Torque Cartridge into Cavity	60 Nm (44 lbs ft)	
Weight	1SB202	0.24 kg (0.53 lbs)
	1SB252	0.64 kg (1.40 lbs)
Seal Kit Number	SK339 (Nitrile)	SK339V (Viton)
Recommended Filtration Level	BS5540/4 Class 18/13 (25 micron nominal)	
Operating Temp	-20°C to +90°C	
Leakage	35 millilitres/min @ 210 bar	
Nominal Viscosity Range	5 to 500 cSt	

Integrated Hydraulics Limited

Collins Road, Heathcote Industrial Estate, Warwick, CV34 6TF, England. Tel: (01926) 881171 Fax: (01926) 315721

13-131.A

Hand Pump 45cc/Cycle with Lever + Relief Valve + 5 Litre reservoir

Specifications

- Double Acting Hand Pump with Lever
- Complete with Reservoir
- 45 c/c per cycle
- Adjustable Relief Valve
- Stainless Steel Piston Rod
- Pump cartridge is all steel construction
- Hi-Strength Aluminium Body
- Nickel Plated Steel Parts
- Low Operating Effort
- High Quality, ISO.9001
- Rugged Construction
- Low leakage
- Long Life, Hard Wearing
- Buna seals are Standard
- Reservoir:-
- 5 Litre capacity
- High Strength Aluminium
- c/w Nickel plated screws
- Gasket
- Breather Plug
- Suction tube to suit
- Weight 6.2 Kg
- Pump suitable for use with-
- ISO.HM.VG.32 Hydraulic Oil

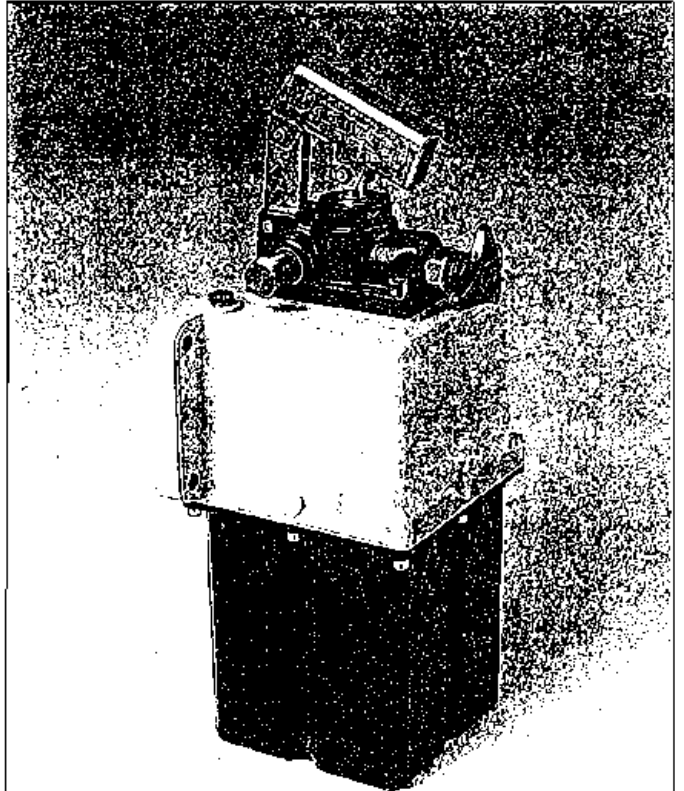

Ordering Code: OMPM 45L VS S5

Hydraulic Circuit

OMP 45L VS S5

Single
Acting
Actuator

3/8" BSP Male

Pressure

Relief
Valve

Suction Return Flows

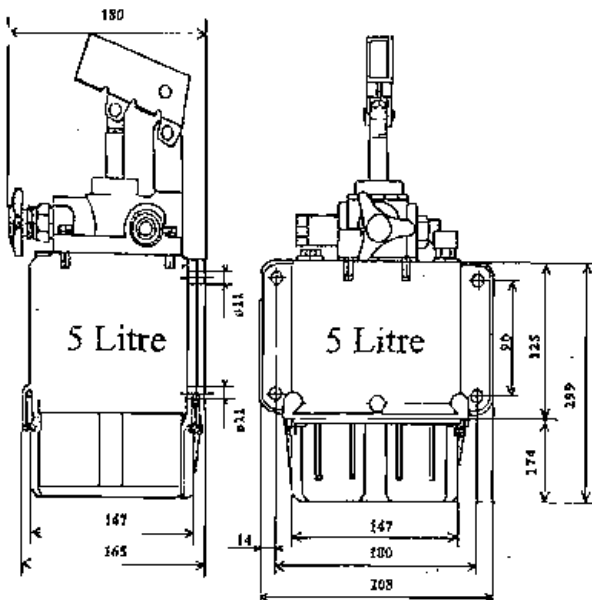
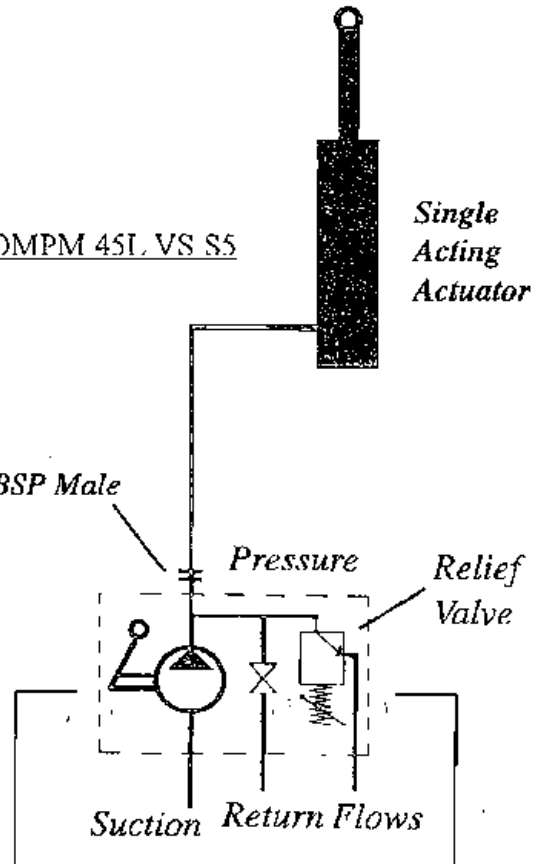

Mounting Instructions see page 16

The Haskel range of Liquid Pumps

The following illustrates some design features of the basic pump types available, from the smallest 1/3 hp series to the large 10 hp high output series.

Haskel pumps were designed to meet an increasing demand for an economical, compact and portable source of hydraulic pressure. They are available in a wide variety of liquid section seal materials (listed on page 9) so that the user can select the best combination of materials to suit the liquid to be pumped.

1/3 hp M Series

Power output is nominally 1/3 hp at 5.86 bar (85 psi) air drive pressure, and up to 1/2 hp, at 8.62 bar (125 psi) air drive pressure. Capable of generating pressures up to 1000 bar (15,000 psi) except the stainless steel versions MS, MCP and 29723 models which have a maximum pressure of 700 bar (10,000 psi). Flow rates up to 10 l/min (600 cu. in./min.) All models operate between 1.8 and 9 bar (25 and 125 psi) air drive pressure. 24 different models available.

Cross section of mini-pump

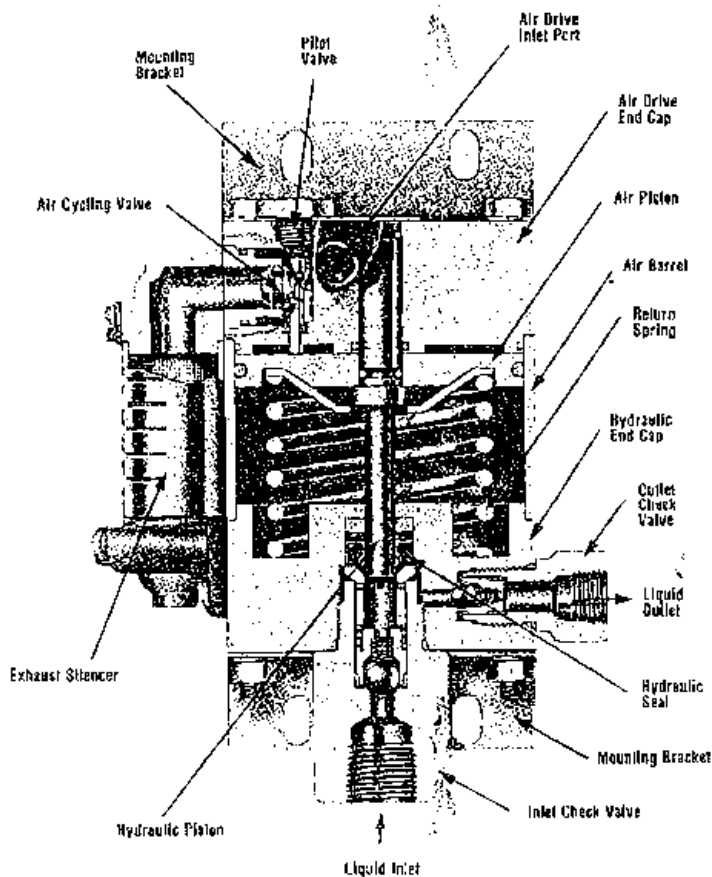

A separation chamber with vent to atmosphere is provided above the Hydraulic Piston on all series except M and MS.

Non-aluminium version available

3/4 hp 1" Stroke 4" Series

Haskel 4" Series Air Driven Pumps develop a full 3/4 hydraulic hp output with 5.9 bar (85 psi) air drive (at approximately 70% of stall). They can handle many of the requirements that previously needed a step up to 1 hp or 1-1/2 hp models. Yet their economical design provides a cost effective and compact envelope low in weight.

The 4" series takes full advantage of Haskel's 24 years of proven design basics: For reliable start up under full load, an unbalanced, air piloted, 4-way valve cycling the drive cylinder and needing no air line lubrication; external air pilot option for remote start/stop control; rugged wear compensating plunger seal design. All stainless steel inlet and outlet ball check valves in the familiar Haskel caged spring and "semi-soft" seat design are standard. The design also includes ready access to all moving parts for simple in-house maintenance.



1/3 hp M-series



3/4 hp 4" Series



2 hp double air head AW-72 model

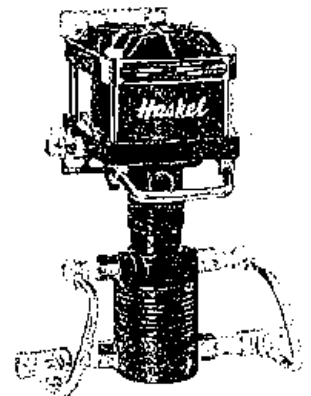

1.5 hp high output BTW-4 pump fitted with distance piece

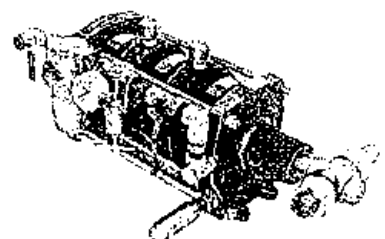

2 hp triple air head B2NW-903 pump

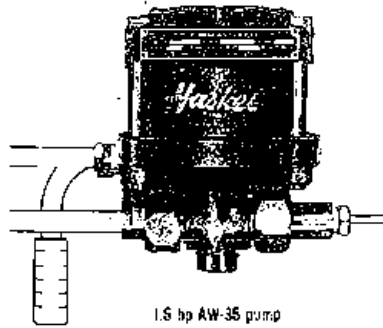

1.5 hp AW-35 pump

Why use air driven pumps?

Whilst compressed air is not the cheapest form of energy to drive a pump it has many inherent operating advantages which far outweigh any operating cost factor.

1. Compressed air used as a power drive reduces risks of excessive heat, flame, spark or shock which are symptomatic of electrical drives.
2. With an air drive, cycling speeds are infinitely variable between zero and maximum giving the ability to vary pump output flow thus offering many operational benefits.
3. The pressure the pump is capable of generating is directly proportional to the air drive pressure. The pump outlet pressure is directly variable by regulating the air drive pressure.
4. Bottled gas, boil-off from a liquid gas tank or natural methane gas can be used as an alternative to drive the pump thus offering a completely self contained power unit independent of external power sources.
5. An air driven pump senses and responds to the outlet condition. Initially the pump is used to transfer fluid thus filling the outlet circuit which means that the pump cycling rate is at maximum. As the circuit becomes filled and outlet pressure builds up the cycling rate progressively reduces until a stall condition is reached, (i.e. the air drive pressure times the pump ratio equals the outlet pressure). This stall pressure can be held indefinitely without any further consumption of energy, generation of heat or wearing of components. When the outlet pressure is reduced—(due to use of the fluid or leak) the pump will automatically restart and will cycle until the stall condition is reached.
6. The installation operation and maintenance of an air driven pump is simpler than the equivalent electrical pump. Service is carried out by a mechanic without having to call on the separate skills of an electrician.
7. Haskel air driven pumps are more capable of generating ultra-high pressures—up to 7000 bar (100,000 psi) in one stage.
8. Haskel air driven pumps are more compact, robust and reliable. There is no metal to metal contact and the seal life is longer because of slower piston speeds.

Principle of Operation

Haskel air driven liquid pumps work on an automatic reciprocating differential area piston principle that uses a large area air drive piston connected to a smaller area hydraulic piston to convert compressed air power into hydraulic power.

The nominal ratio between the area of the air drive piston and the hydraulic driven piston is indicated by the number in the model description and approximates the maximum pressure the pump is capable of generating. Unlike other air driven pumps the actual ratio is approximately 15% higher than the nominal so that the pump will still cycle when the ratio of the output hydraulic pressure to the air drive pressure equals the nominal ratio. For example an AW-35 has an actual ratio of 40:1.

Example

If air drive piston area = 400 sq. cm.
and liquid piston area = 10 sq. cm.
then actual pump ratio = 40:1
and nominal pump ratio = 35:1

If air drive pressure = 5 bar
the maximum outlet pressure = 5 x 35 = 175 bar

If the air drive pressure is increased to 7 bar then maximum outlet pressure will be 245 bar

When compressed air is first applied to the pump it will cycle at its maximum speed producing maximum flow and act as a transfer pump filling the pressure receiver with liquid. The pump will then gradually start to cycle at a slower rate as the pressure in the receiver increases and offers more resistance to the reciprocating differential piston assembly, until it stops (stalls) when a balance of forces is reached, i.e. when—air drive pressure x air drive piston area = stall pressure x driven hydraulic piston area.

The hydraulic pressure drop (hysteresis) required to cause the Haskel air driven pump to restart is extremely small due to the very low frictional resistance offered by the large diameter air drive piston seal.

Double and Triple Air Head Pumps

The performance of the pumps in the 1.5 horse power (hp) range can be extended by stacking air pistons on top of each other to double or triple the intensification ratio, without changing the hydraulic piston. The double or triple air head pumps consume less air than competitors pumps with a single air piston of equivalent area since only one of the two or three heads is pressurised on the return stroke.

The addition of a second and third air head increased the pump hp from approximately 1.5 to 2 hp.

Double air head pumps are identified by the last digit 2 in the pump model number. Thus, a nominal 25:1 ratio pump with two air heads is described as a—32. Similarly, a triple air head pump is identified with a last digit 3. Thus a 900 ratio pump with 3 air heads is described as a—903.

Horsepower ratings

Horsepower ratings peak at 7 bar (100 psi) air drive pressure and are approximate. They assume an ample air supply at adequate air pressure at the pump. Freezing of exhaust mufflers on humid days, inadequate air drive pipe line sizes, dirty air filters, etc can affect the performance of any pump. Peak hp is obtained at approximately 75% of nominal ratio x air drive pressure i.e. 100:1 pump being driven at 7 bar (100 psi) will produce peak power at a hydraulic output pressure of $100 \times 100 \times 0.75 = 517$ bar (7500 psi) approximately.

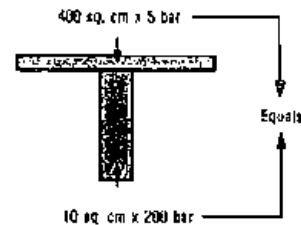
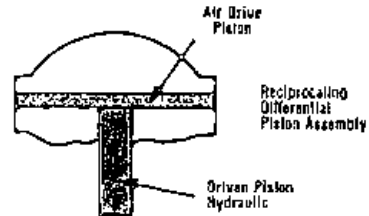

Double Air Head Pump

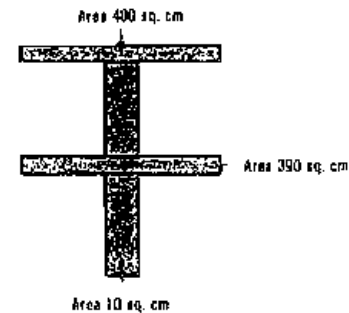

Therefore actual ratio = 79:1
Nominal ratio = 72:1

Pump Model and Seal Coding

M	1" Stroke 1/3 hp mini pump series.
S	Corrosion resistant hydraulic piston and body.
MCP	1/3 hp Chemical Pump.
D (Prefix)	Pump incorporates a Distance Piece.
D (Suffix)	Double Acting Pump.
4"	1" Stroke 3/4 hp Pump Series
A	2" Stroke 1.5 + 2 hp Pump Series
H	2" Stroke 1.5 + 2 hp High Pressure Pump Series.
XH	2" Stroke 1.5 + 2 hp Extreme High Pressure Pump Series.
C	4" Stroke 6 hp Pump Series.
14"	4" Stroke 10 hp Pump Series
W	Polyurethane U-cup dynamic seal.
F	UHMWPE (Ultra-high molecular weight polyethylene seal.)
T	Reinforced Teflon dynamic seal.
V	Viton O Ring static seal.
-C	Air Controls including Exhaust Silencer.
-D	Exhaust Silencer only.

Introducing Haskel air driven liquid pumps

The Haskel range of liquid pumps, accessories, modifications and options is the most comprehensive available and allows the construction of test systems and rigs to precise design parameters to meet customers exacting specifications. Haskel air driven pumps offer many advantages over conventional electrical driven units as follows:

- Ability to stall at any predetermined pressure and hold this fixed pressure without consuming power or generating heat.
- No heat, flame or spark risk.
- Infinitely variable cycling speed and output.
- Up to 7000 bar (100,000 psi) pressure capability.
- Easy to apply automatic controls.
- No limit or adverse effect to continuous stop/start applications.
- Air drive does not require an external line lubricator thus saving on running cost and preventing oil vapour contamination of the surrounding environment.
- Reliable, easy to maintain, compact and robust.

Haskel pumps use patented seal systems to give a long working life and are capable of successfully pumping and pressurising a wide variety of liquids.

Haskel products are backed by an International Network of highly trained Distributors with application engineering expertise who can provide a complete problem solving service.

What is a Haskel air driven liquid pump?

An air driven pump consists of:

1. **AIR DRIVE SECTION**—This consists of a light weight inertia reducing piston complete with 'O' ring seal inside an epoxy filled wound fibreglass barrel. The diameter of the air piston is constant for any series of air driven pumps. When compressed air is fed into the air drive it forces the piston down on the compression stroke. The air then drives the piston back on the suction stroke [except in the case of the M series pumps which have a spring return]. Air drive line lubricators are not required nor desired due to the inherent low friction characteristics of the design and pre-lubrication during assembly.

2. **HYDRAULIC SECTION**—The hydraulic piston is directly linked to the air piston and its lower portion is housed inside the hydraulic body. Its diameter determines the ratio of the pump (for any particular series) which in turn determines the outlet flow and maximum pressure capability. Its function is to induce liquid into the hydraulic body through the inlet check valve and force it out through the outlet check valve at a higher pressure.

3. **AIR CYCLING VALVE**—This consists of a pilot operated unbalanced light weight spool which channels the compressed air first to the top of the piston then to the underside causing it to reciprocate (cycle). The air piston actuates pilot valves at the top and bottom of its stroke which causes the unbalanced spool to reciprocate thus re-directing the flow of air. The air is exhausted from the pump through an exhaust silencer.

4. **HYDRAULIC SEAL**—This encircles the hydraulic piston and is one of the few wearing parts. Its function is to allow the hydraulic piston to reciprocate without letting any liquid pass into the air drive. Different materials and configurations are used based on the specification of the liquid to be pumped, temperature of the liquid and the pressure to be generated.

N.B. With most Haskel pumps a distance piece can be incorporated between the air drive section and the hydraulic section for complete separation and contaminant free operation.

5. **CHECK VALVES**—These are spring loaded non-return valves that control the inlet and outlet liquid into and out of the pump. When the hydraulic piston is on the suction stroke the inlet check valve opens to the maximum, the liquid is induced into the pump whilst the outlet check valve is held closed by its spring. On the pressure stroke the inlet check valve is closed as the hydraulic piston pressurises the liquid out through the outlet check valve.

MAIN SECTIONS OF PUMP

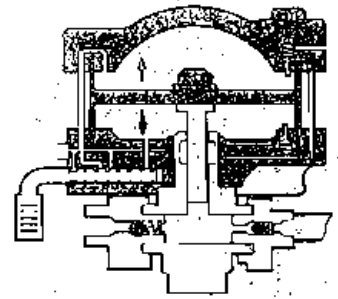

1. Air Drive Section

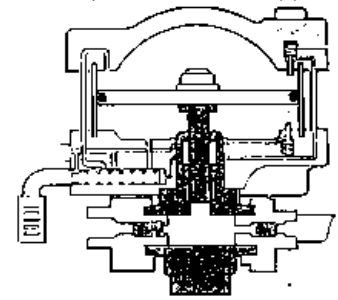

2. Hydraulic Section

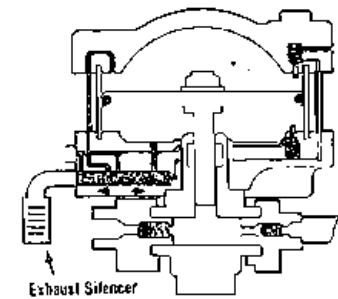

Exhaust Silencer

3. Air Cycling Valve Assembly

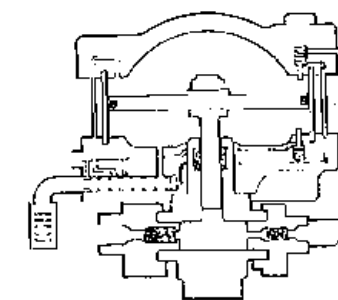

4. Hydraulic Seal

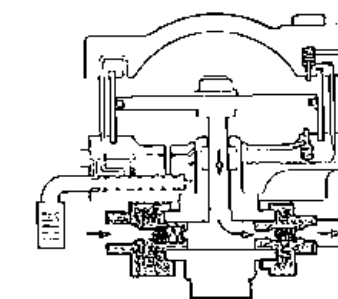

5. Check Valves

INDEX

Introducing Haskel Air Driven Liquid Pumps	2	Accessories and Options-1/3 hp—10hp Series	10/11
What is a Haskel Air Driven Liquid Pump?	2	System Components and Accessories	12/13
Why use Haskel Air Driven Pumps?	3	Typical Haskel Pump Circuit for Pressure Testing a Receiver Via Air Pipelines	14
Principle of Operation	3	Examples of Use and Systems	15
Double and Triple Air Head Pumps	3	Typical Applications: Strapping	16
horsepower Ratings	3	Jacking/Lifting	16
Pump Model and Seal Coding	3	Wet Torquing/Bolt Tensioning	16
The Haskel Range of Liquid Pumps	4	Roller Tensioning	16
1/3 hp M Series	4	Stamping	16
3/4 hp A Series	4	Cutting	16
1.5 + 2 hp A, H, XH Series	6	Press Overload	16
2.2 hp AFD-860 Series	6	Brake Actuation	16
1.5 hp High Output Flow Series	6	Valve Actuation	16
6 hp B Series	7	Chemical Injection	16
10 hp 14" Series	7	Recommendations when selecting and using High Pressure	17
Pump Model Selection Chart	8	Hydraulic Equipment	17
Liquids Compatible with Haskel Pumps	9	Definition of Abbreviation and Conversions	17
Wetted Section Materials	9		

SEE M-LP20, M-LP25, M-LP28, M-LP4/16, M-LP 14" HASKEL LEAFLETS FOR TECHNICAL SPECIFICATIONS AND PERFORMANCE DATA ON THE:
 1/3 hp M-Series Pumps 3/4 hp Series Pumps 1.5-2 hp A, X and H Series Pumps
 6 hp G-Series Pumps 10 hp 14" Series Pumps

Acceptable operating temperature for Haskel Liquid Pumps

There are two distinct sections: The air drive section and the liquid pump section.

AIR DRIVE SECTION

The ambient air condition is normally all that need be considered since this will usually determine the temperature of the air or gas drive seals and other static components. Standard air drive sections should cycle reliably within an ambient range of -4°C to 85°C (40° to 150°F). Lower temperatures will cause excessive air gas leakage, higher temperatures and reduced seal life. Drive air directly from a compressor should ideally be warm before entering the air gas drive. See page 11 for low temperature modification.

LIQUID SECTION

Low temperatures normally have little effect on the operation of standard parts and seals. The most important consideration is the effect on the liquid either freezing or an increase in viscosity (which can generate cavitation on the suction stroke). For reasonable seal life temperature should be 52° to 54°C (125° to 130°F) for the 'F' or 'W' seal (275°F) for the 'T' or 'TV' seal models (with distance piece). See page 11 for double distance piece option.

Liquids compatible with Haskel Pumps

One of the more important features of the Haskel pump is the seal assembly for the hydraulic piston. Haskels expertise in this field is considerable. Longer life and more versatile seals are continually being developed, the most recent addition is UHMWPE (Ultra High Molecular Weight)

Polyethylene) code name 'F'. This new seal extends pump cycle life over 100 times. Ideal for tap water, sea water and deionised/demineralised water. Operating pressures up to 4827 bar (70,000 psi). Hydraulic piston seal life with non-lubricating fluids will understandably be less than with oils.

The following liquids are classified in groups and allocated a service code number. The service code numbers are referred to in the table below which indicates the models and ratios of pumps which can satisfactorily pump and pressurise each type of liquid.

- (1) Petroleum base oils, Kerosene, Diesel fuel, water with 5% soluble oil
 - (2) Plain water, sea water
 - (3) Most Phosphate Ester base fire resistant hydraulic fluids; e.g. Pydraul, Lindol, Cellulube, Fyrqual, and Houghtsate 1120 and some Petroleum base solvents compatible with UHMWPE (Ultra High Molecular Weight Polyethylene) dynamic and Viton static seals.
 - (4) Petroleum base solvents e.g. Boron fuels, Aromatic hydrocarbons, (Benzene, Toluene, Xylene, Hylene, etc.); Chlorinated solvents, (Trichloroethylene, Carbon Tetrachloride, Chlorobenzene, etc.); Mercaptans, Dowtherm A, Fluorinated solvents (Fluorobenzene, Fluorochloroethylene, etc.); Dowtherm E, plus all of group 3 plus some mildly corrosive acids compatible with wetted materials. See note 5A for service with Methyl-Ethyl-Ketone, Methyl Acetone, Diacetone, Alcohol, Freon 22.
 - (5) Skydrol and Aerosale hydraulic fluid, Acetone and some Alcohols (Ethyl, Methyl and Isopropyl).
 - (5a) Also suitable for these fluids if Viton Static Seals replaced with EPR, specify modification number 51331 (no extra charge), e.g. 51331-DF-60.
 - (6) Deionized water, Demineralised water.
- Note Dynamic seal life with non-lubricating fluids will understandably be less than with lubricating types.

WETTED MATERIALS OF CONSTRUCTION

PUMP SERIES	SERVICE	SEAL PACKAGE	PUMP BODY	PISTON	BEARINGS	INLET AND OUTLET CHECK VALVES		
						FITTINGS	BALLS	DISCS
M	1	Polyurethane (W)	Cadmium Plated Carbon Steel	416 SS	SAE 659 Bronze	1137 Cold Fin Cadmium Plated	SS	NA
MS MCP 29723 MOTV	1.2 1.2,3,4,5, 1.2,3,5,6, 1.3,5A	UHMWPE (F) Teflon (T) UHMWPE (F) Teflon (T) and Viton (V)	303 SS 303 SS 303 SS Diaphragm—Aluminium Barrel—316 SS End Cap—Aluminium	416 SS 15.5PH SS 15.5PH SS Piston Head—303 SS Piston Rod—416 SS	Annealed R1834 Nylon Annealed R1834 Nylon Annealed R1834 Nylon Annealed R1834 Nylon Reinforced Teflon	303 SS 303 SS 303 SS 303 SS NA	316 SS 316 SS 316 SS 316 SS NA	NA NA NA NA Outlet 303 SS Inlet 15.5PH SS
MUSTV	1.2,3,4,5A	Teflon (T) and Viton (V)	Diaphragm—303 SS Barrel—316 SS End Cap—303 SS	Piston Head—303 SS Piston Rod—416 SS	Annealed R1834 Nylon Reinforced Teflon	NA	NA	Outlet 303 SS Inlet 15.5PH SS
4B 14-37	1.2	UHMWPE (F) or Polyurethane (W)	Anodized Cast Aluminium	416 Corrosion resistant	Nylon	303 SS	316 SS	NA
4B 55-150	1.2	UHMWPE (F) or Polyurethane (W)	Anodized Cast Aluminium with AISI303 Insert	416 Corrosion resistant	Nylon	303 SS	316 SS	NA
AW	1.2	Polyurethane (W) and Buna-N	Nickel Plated Carbon or Chromoly Steel	440-C SS	Aluminium Bronze	303 SS	316 SS	NA
AFD	1	UHMWPE (F)	Nickel Plated Carbon Steel	418 SS	Aluminium Bronze	416 SS	316 & 440-C SS	NA
ASF	1.2	Raflo B10, B15, B22, B32— UHMWPE (F) and Nylon	303 SS	Hard Chromed Plated 440-C SS	Reinforced Teflon	303 SS	316 SS	NA
BF	1.2,3,5A	Other Ratels	Nickel Plated Carbon or Chromoly Steel	440-C SS	Aluminium Bronze	303 SS	316 SS	NA
BSF	1.2,3,5A,6	UHMWPE (F) Nylon & Viton	303 SS	440-C SS	Reinforced Teflon	303 SS	316 SS	NA
BW	1.2	Polyurethane (W) & Buna-N	Nickel Plated Chromoly Steel	Ste lite 1	Aluminium Bronze	15.5PH SS	440 SS	NA
BSF	1.2	UHMWPE (F)	15.5PH SS	Ste lite	Reinforced Teflon	15.5PH SS	440 SS	NA
DNF	1.2,3,5	UHMWPE (F)	Nickel Plated Chromoly Steel	Stellite	Aluminium Bronze	15.5PH SS	440 SS	NA
BSAF	1.2,3,5,6	UHMWPE (F)	15.5PH SS	Stellite	Reinforced Teflon	15.5PH SS	440 SS	NA
DXNF	1.2,3,5	UHMWPE (F)	Nickel Plated Chromoly Steel— Auto-Frettaged	Stellite	Aluminium Bronze	15.5PH SS	440 SS	NA
DSXHW	1.2,3,5,6	UHMWPE (F)	15.5PH SS Auto-Frettaged	Stellite	Reinforced Teflon	15.5PH SS	440 SS	NA
BSTV	1.2,3,4,5A	Teflon (T) and Viton (V)	303 SS	Hard Chrm. Pltd. 440-C SS	Reinforced Teflon	303 SS	316 SS	NA
ATV-4	1.2	Teflon (T) and Viton (V)	Aluminium Bronze, 304 SS Liner	303 SS	Reinforced Teflon	303 SS	316 SS	NA
DTV-4	1.2,5A	Teflon (T) and Viton (V)	Aluminium Bronze, 304 SS Liner	303 SS	Reinforced Teflon	303 SS	316 SS	NA
DSTV-1.5	1.2,3,4,5A,6	Teflon (T) and Viton (V)	303 SS 2 Raflo B10, B15, B22 & B32	17.4PH SS 1 202 Raflo 15 hard Chrome Plated 440-C SS	Reinforced Teflon	17.7PH SS	318 SS	NA
GW	1	Polyurethane (W)	416 SS & Nickel Plated 4340 Steel	Piston Head—Chrome Plated 4340 Steel Piston Rod 303 SS	Bronze	NA	440-C SS	303 SS
GSF	1.2	UHMWPE (F)	418 SS & 17.4PH SS	Piston Head—15.5PH SS	Nylon	NA	440-C SS	303 SS
DGF	1.3,5A	UHMWPE (F)	416 SS & Nickel Plated 4340 Steel	Piston Rod 303 SS, Piston Head—Chrome Plated 4340 Steel	Nylon	NA	440-C SS	303 SS
DGSF	1.2,3,5A,6	UHMWPE (F)	418 SS or 17.4PH SS	Piston Head—303 SS Piston Rod—303 SS	Nylon	NA	440-C SS	303 SS
DGSTV	1.2,3,4,5A	Teflon (T) and Viton (V)	418 SS or 17.4PH SS	Piston Head—15.5PH SS Piston Rod—303 SS	Nylon	NA	440-C SS	303 SS
GWD	1	Polyurethane (W)	Nickel Plated 1215 Steel	Piston Head—15.5PH SS Piston Rod—308 SS	Bronze	303 SS	318 SS	303 SS
GSPD	1.2	UHMWPE (F)	318 and 15.5PH SS	Piston Head—15.5PH SS Piston Rod—303 SS	Nylon	303 SS	318 SS	303 SS
DGFD	1.3,5A	UHMWPE (F)	316 and 15.5PH SS	Piston Head—303 SS	Nylon	303 SS	316 SS	303 SS
DGSFD	1.2,3,5A,6	UHMWPE (F)	316 and 15.5PH SS	Piston Rod—303 SS	Nylon	303 SS	316 SS	303 SS
DGSTVD	1.2,3,4,5A	Teflon (T) and Viton (V)	316 and 15.5PH SS	Piston Rod—303 SS	Nylon	303 SS	316 SS	303 SS
D14STB-125	1.2,3,4,5A,6	Teflon (T) and Viton (V)	15.5PH Electro Polished SS	15.5PH SS	SAE 660 Bronze	15.5PH SS	17.4PH SS	NA
D14STD-315	1.2,3,4,5A,6	Teflon (T) and Viton (V)	15.5PH Electro Polished SS	15.5PH SS	SAE 660 Bronze	15.5PH SS	17.4PH SS	NA
D14SFD-125	1.2,3,5A,6	UHMWPE (F)	15.5PH Electro Polished SS	Tungsten Carbide Ctd. 15.5PH SS	Nylon	15.5PH SS	17.4PH SS	NA
D14SFD-315	1.2,3,5A,6	Teflon (T), Viton (V)	15.5PH Electro Polished SS	Tungsten Carbide Ctd. 15.5PH SS	Nylon	15.5PH SS	17.4PH SS	NA

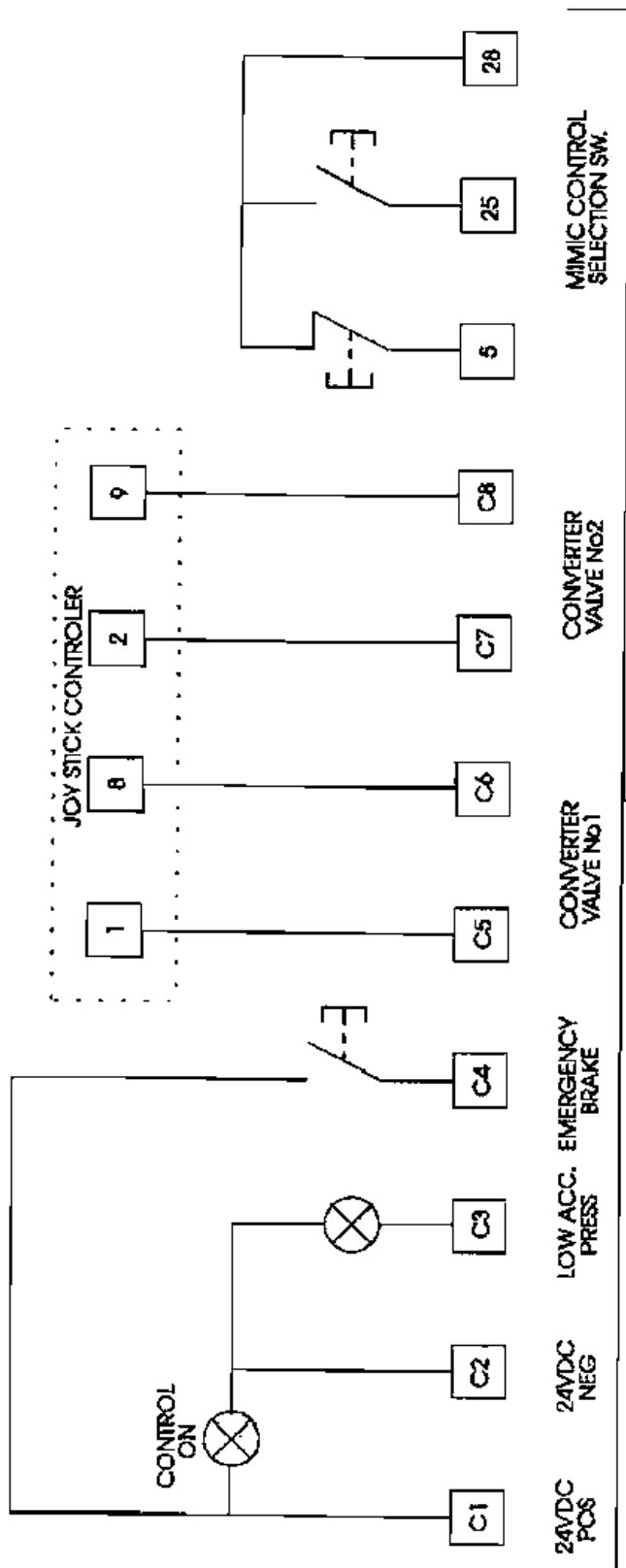

PANEL No1

Customer:-	Armstrong Hyd.	MCR ELECTRICAL ENGINEERS PULLING THE COVERS OFF HIS COMPONENTS TO MAKE THEM WORKABLE TO A THIRD PARTY OR APPROVED WITHOUT REMOVAL OF PARTS FROM THE CHASSIS. THE DRAWING MUST NOT BE USED IN CONNECTION WITH ANY INFORMATION FOR THE MAKING OF ANY APPARATUS OR PARTS THEREOF.
Joystick control mimic No.3		MCR ELECTRICAL ENGINEERS (HULL) Tel:01482 569062 FAX:01482 589525
Job No.	1329	
Drawing No:	001	
Issue No:	001	
Date of issue	1/04/97	

Installation

ICS4/ ICT4

Dimensions ICT4 (mm)

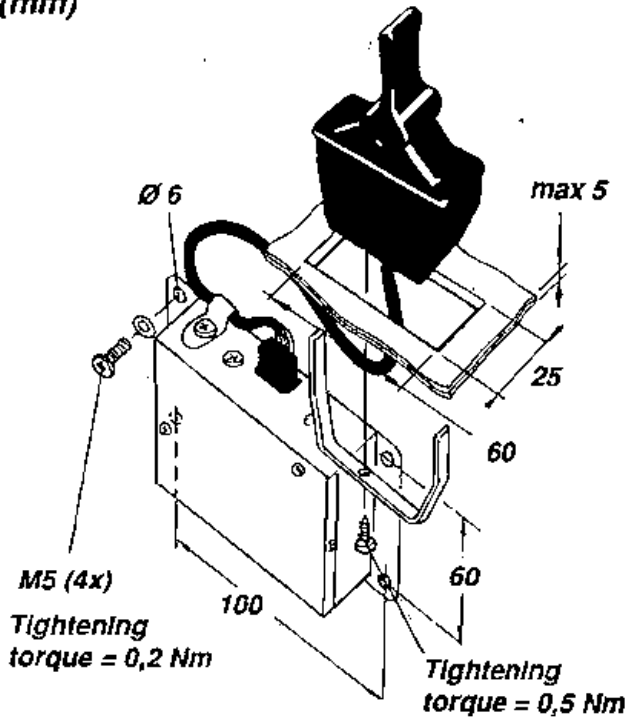

Dimensions ICS4 (mm)

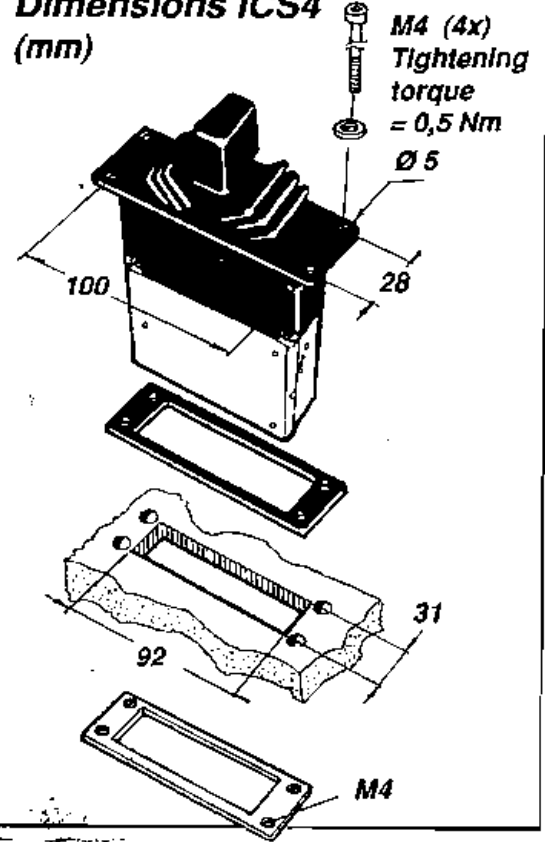

Circuit diagram

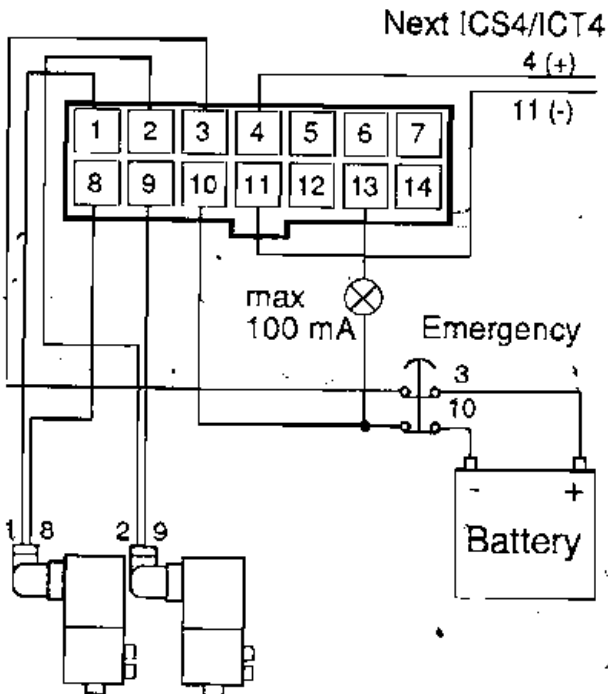

Cable length 0 - 5 m, area min 0,5 mm²
 Cable length 5 - 30 m (max), area min 0,75 mm²
 (1, 2, 8, 9, 13)
 Battery (+, -) cable area min 1,0 mm² (3, 4, 10, 11)

No CRF

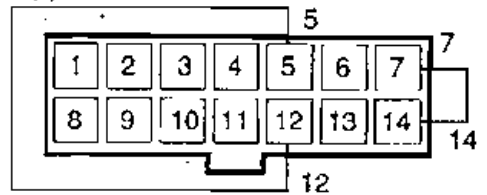

or CRF Cable length max 0,5 m
 Cable area min 0,25 mm²
 (5, 6, 7, 12, 14)

