

Synopsis: *Prospero's* loss of pod control, the Gulf of Finland 20th September 2006

**DNV**

DET NORSKE VERITAS  
**SURVEY REPORT**

Rev. [1]

Name of vessel <b>PROSPERO</b>		Name of owner <b>Partrederiet för M/T "Prospero"</b>	DNV id. no. <b>22081</b>	Job Id.
			IMO no. <b>9212589</b>	

### Pod control system failure

This is to confirm that the following has been carried out:

#### Surveys

Survey Code	Survey Name	Result
MACHDAM.O	Machinery damage occasional -	Complete

Conditions and Memoranda - Given		Due Date
CC 12	Pod control transmitting unit (gauss) to be repaired. Finding(s): <b>[Propulsion pod, azimuth A &gt; Control and monitoring system A]</b> Malfunction	2006-12-21
MO 13	As long as the CC related to pod control is in force, the crew are to perform and log regular inspections of stoppers fitted to pod control levers and condition of control cables in the pod and in the pod room.	

Station <b>x</b>	Place of survey	Survey started <b>2006-09-20</b>	Survey completed <b>2006-09-21</b>	Stamp
Lead surveyor's name	Lead surveyor's signature			
Surveyor's name	Surveyor's signature			

If any person suffers loss or damage which is proved to have been caused by any negligent act or omission of Det Norske Veritas, then Det Norske Veritas shall pay compensation to such person for his proved direct loss or damage. However, the compensation shall not exceed an amount equal to ten times the fee charged for the service in question, provided that the maximum compensation shall never exceed USD 2 million. In this provision "Det Norske Veritas" shall mean the Foundation Det Norske Veritas as well as all its subsidiaries, directors, officers, employees, agents and any other acting on behalf of Det Norske Veritas.

Name of vessel <b>PROSPERO</b>	Name of owner <b>Partrederiet för M/T "Prospero"</b>	DNV id. no. <b>22081</b>	Job Id..
-----------------------------------	---	-----------------------------	----------

## Survey Observations and Findings

### Propulsion pod, azimuth A

As reported by crew, the vessel was eastbound in Gulf of Finland in early 20.09.2006, when an alarm of pod control unit fault 1&2 was raised, consequently the pod control was inoperative. Upon investigation, the fault was detected to be the device transmitting control signals from the turning pod to the control units, later called as gauss. Short emergency cables provided as spares onboard were connected in order to by-pass the gauss thus making the manoeuvring possible though limited in terms of pod steering angle. Vessel proceeded towards Hanko, last stage with tug assistance and anchored in Hanko Roads.

Vessel was attended 20.09. midnight together with two engineers from the pod maker Schottel Siemens. After investigation, the engineers agreed the fault being the defected gauss, which was dismantled and sent to the factory for inspection. Decision if it can be repaired or a new one to be produced is not yet done. New four meter long cables were fitted by-passing the gauss.

On attendance late evening 21.09. installation was finished. The pod control was tested from all positions (down inside the pod, local in pod room, ECR console, bridge console and both bridge wings). From local control at pod room was tested the pod turning full 360 degrees in both ways. Transformers local control panels 1&2 were clean of alarms. The control levers in bridge console, bridge wings and ECR console were fitted with mechanical stoppers in order to prevent the pod turning more than 180 degrees and signboards fitted besides all control positions. A short sea trial was done while pilot onboard incl. full turning the vessel. All installation and testing was satisfactory.

The modification done is creating a limitation to the pod operation; now the pod can not be turned around full turns 360 degrees unlimited times due to the cables being then twisted and damaged. Noted that only the manoeuvring mode is concerned, the sea going mode is limited anyway to +/- 30 degrees. Since the operational way is deviating from the original design, the modification was deemed as a temporary one and a CC was issued for permanent repairs (or alternatively seeking approval of the modified system of transmitting control signals from the pod). Additionally, a MO was issued for the crew to perform and log regular inspections of the control lever stoppers and control cable condition under cover.

### Findings

[Control and monitoring system A]

Malfunction

[Issued as part of CC 12]



Final assembly. Cables coming through a pipe in center and continuing to the control units.



Control lever stoppers and signboard seen in stbd bridge wing, typical for all control positions.

Name of vessel <b>PROSPERO</b>	Name of owner <b>Partrederiet för M/T "Prospero"</b>	DNV id. no. <b>22081</b>	Job Id..
-----------------------------------	---	-----------------------------	----------



As original. Arrow on the right showing the control cables coming from underneath the pod and connected to the gauss. Arrow on the left showing the control cable connected to the otherside of the gauss and continuing to control units.

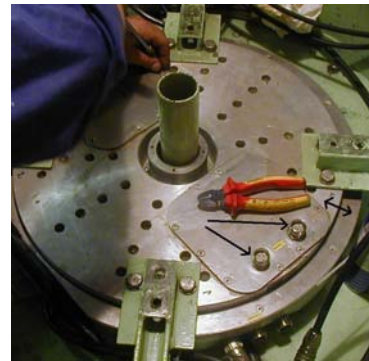

Indicator baseplate taken off. Arrows on the left showing the control cable plugs on the gauss fixed part. Arrow on the right showing the contact surface of the gauss turning part.



Assembly as original (cover taken off) above pod room deck.

General details of the Siemens-Schottel propulsor system

# The SSP Propulsor

## An Ingenious Podded Drive System

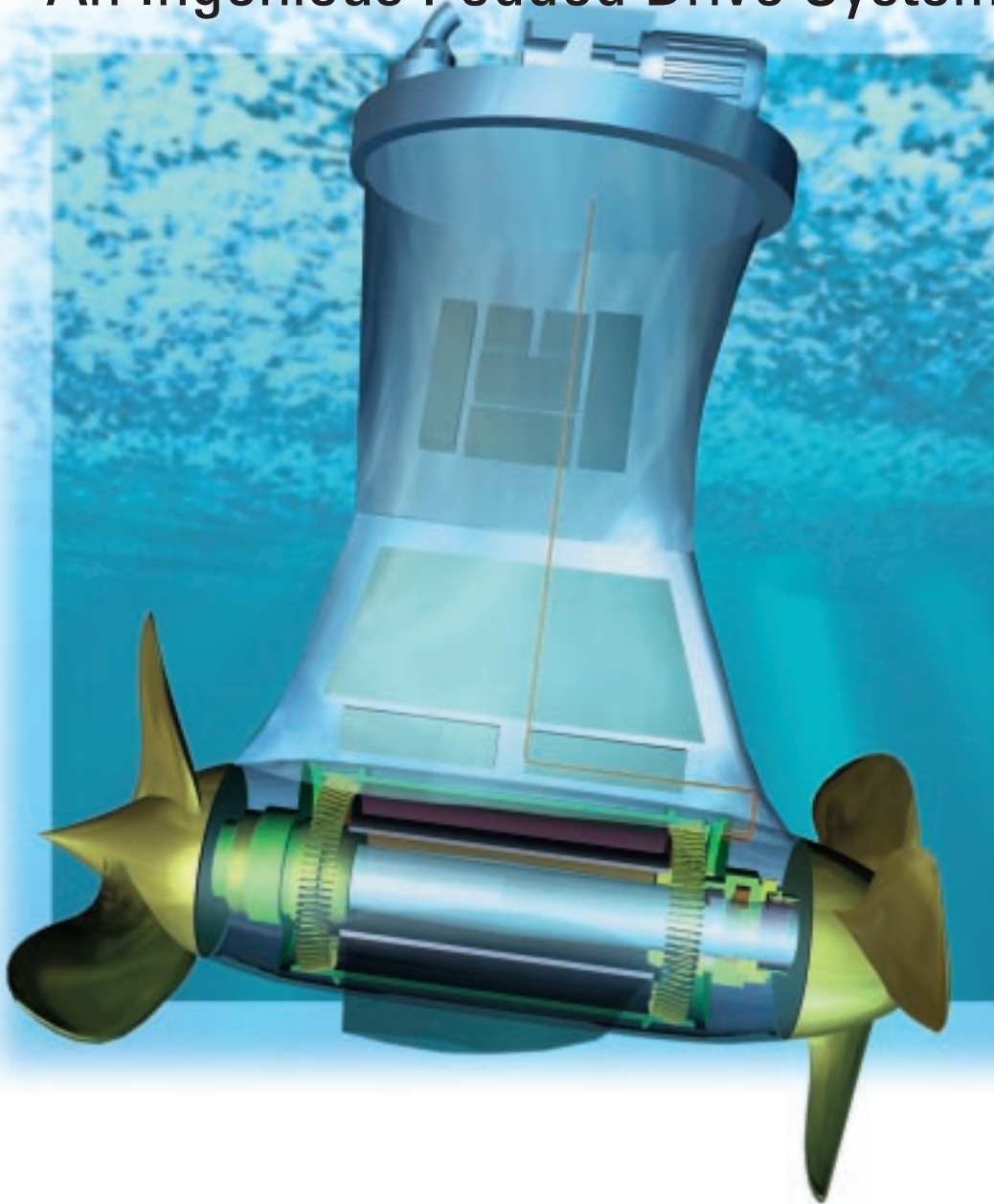

C O N S O R T I U M   S S P

**SIEMENS**



# The SSP Propulsor – a concept of genius, the most efficient podded drive available

The **CONSORTIUM SSP**, a consortium of **SCHOTTEL GmbH & Co. KG** and **Siemens AG, Marine Solutions**, has developed a new podded azimuthing diesel-electric propulsion system for power outputs in the range of 5 to 20 MW per unit.

Thanks to optimum hydrodynamic design and the new permanently-excited propulsion motor, the **SSP Propulsor** is the first diesel-electric drive system which proves significantly more efficient than a conventional diesel-direct drive system or azimuth thruster. These benefits, combined with the proven excellent manoeuvrability of an azimuthing drive, explain the new system's attraction to cost-conscious ship owners.

The new podded diesel-electric azimuth drive is especially suitable for all kinds of vessels requiring high electric power demands aboard and high manoeuvrability. It is also suitable for vessels with frequent changes of power output, such as cruise ships, large ferries and passenger vessels, medium-sized cargo vessels (feeder container vessels and chemical tankers, for instance), ice-going vessels, offshore vessels and structures of all kinds, plus navy vessels.

As already proven by tank tests and full-scale tests, the **SSP Propulsor** can guarantee energy savings of more than 10% over conventional diesel-direct systems or azimuth thrusters.



Nils Holgersson

Lübeck

FRESH WATER

VOID



# Consider the enormous benefits of SSP

## Main benefits

- Efficiency increased up to 10% and more in optimum cases
- No external cooling necessary
- Elimination of rudder, shaftline, bossings, aft tunnel thrusters
- Suitable for a wide variety of stern hull designs
- No cooling systems or cooling air ducts and fans, which saves space and simplifies installation
- Flexible design options for stern and engine room
- Increased cargo space
- The modular design principle allows installation of the propulsion module just before the vessel is launched
- Mounting and dismounting of the propulsion module is possible while the vessel is afloat
- Optimum manoeuvrability without additional stern thrusters, especially at low vessel speed
- Minimized crash stop-time
- Increased safety and easier handling of the vessel
- High on-board comfort on account of extreme low noise and vibration levels
- Low service and maintenance costs due to minimized number of parts
- Reduced exhaust gas emission at rated vessel speed as a result of lower power consumption and optimum manoeuvrability

## SSP power ranges

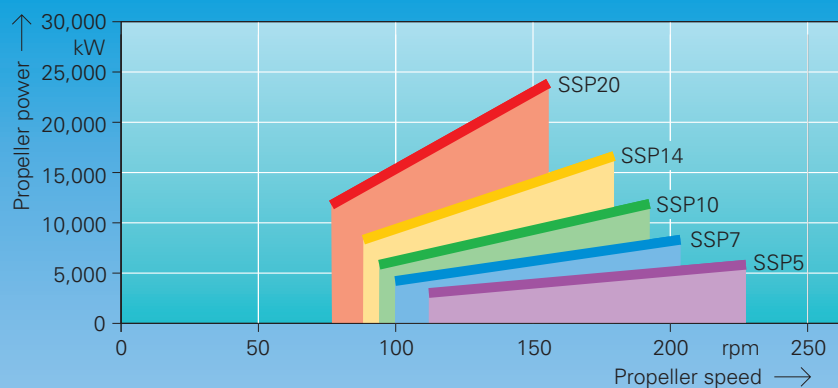

# What are the differences?

Steerable azimuth drive systems with single propeller are available with mechanically geared power transmission up to about 8 MW and, at present, with electrical power transmission up to 20 MW per unit. In general, these azimuth drives are as efficient as conventional shaft line systems.

The improved efficiency of the **SSP Propulsor** results from its twin propeller technology, combined with the hydrodynamically optimized propulsion module, and from the permanently-excited propulsion motor.

The twin propeller technology comprises two propellers on a common shaft. These two three-bladed propellers rotate in the same direction and are located in front and behind the propulsion module, which includes the permanently-excited propulsion motor. This configuration has the advantage of sharing the load between the propellers with maximum productivity from both. The two fins mounted between the propellers on the propulsion module also increase the overall efficiency, along with the propulsor's strut by gaining back the swirl energy.

The diameter and weight of the newly-developed, permanently-excited synchronous propulsion motor are significantly lower compared with conventional, electrically-excited synchro-

nous motors. It has therefore been possible to reduce the diameter of the propulsion module that accommodates the motor. As a result, the housing/propeller diameter ratio can be reduced to 35–40%, which has a dramatic effect on the overall efficiency of the **SSP Propulsor**.

Furthermore, the permanently-excited propulsion motor itself is about 2% more efficient because there is no electrical excitation or associated equipment, and no external air-ventilation. According to its design, the motor needs no brushings, sliprings and ventilators.

Efficiency correction for propeller hub/diameter ratio

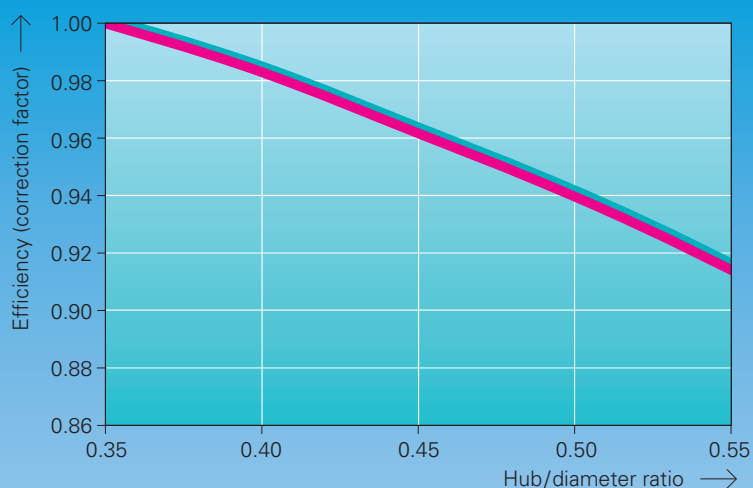

# Test results

The hydrodynamic basis of the SSP is the twin propeller concept developed by SCHOTTEL.

Extensive tests are carried out in advance with various ship designs in order to prove the outstanding values of efficiency and noise inductions.

The tests comprise cruise liners in different executions as well as RoRo ferries, conventional cargo vessels and offshore applications.

The tests in general show hydrodynamic efficiency improvements of up to 10% and more in optimum cases. The risk of cavitation and noise inductions are reduced to a minimum.

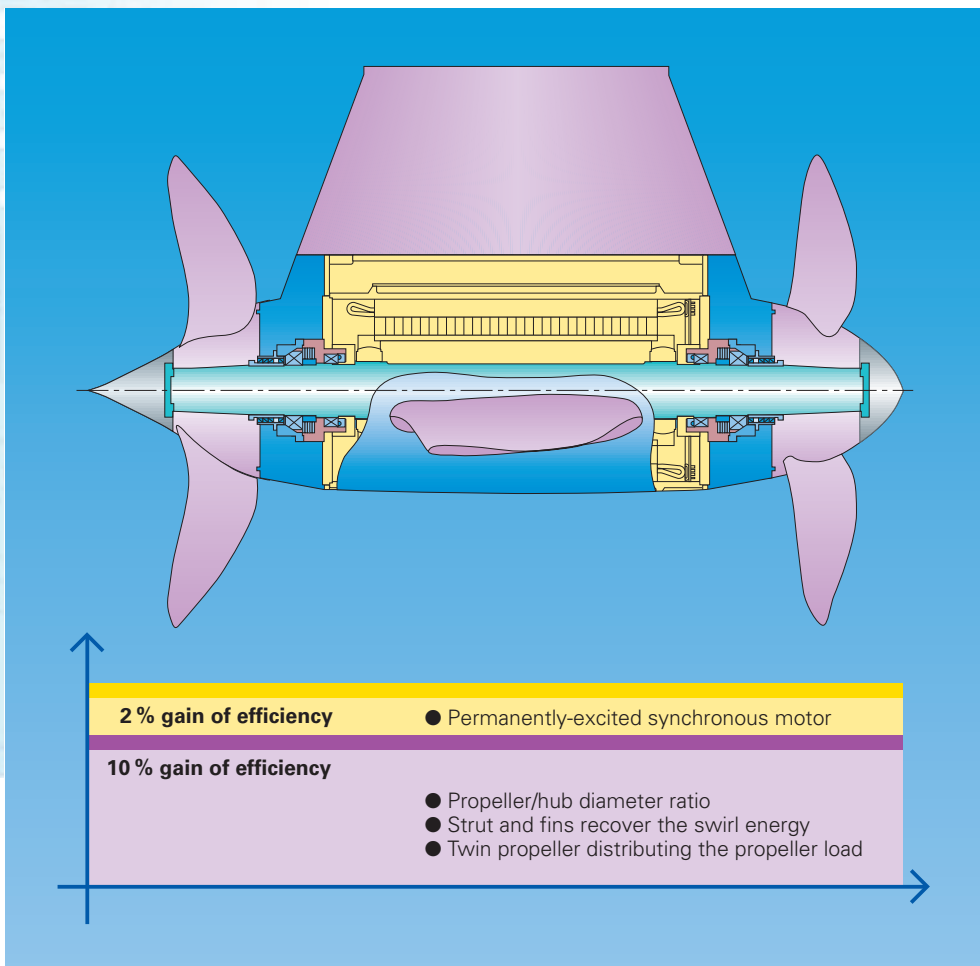

The efficiency



# Mechanical design

The **SSP Propulsor** is based on a unique modular design. Two main modules – the azimuth module and the propulsion module – are flanged together at the ship's hull line.

## Azimuth module

The azimuth module consists of a cone-type support flanged onto the vessel's structure and is made from shipbuilding steel. The following items are installed in the azimuth module:

- Slipping unit to allow unlimited azimuth steering
- Electric/hydraulic azimuth steering system
- Local indicators
- Propeller shaft seal high tank
- Activation system for the emergency seals
- Hydraulic system for the blocking brake
- Bearing lubrication system
- Monitoring system.

## Propulsion module

The propulsion module has a cast housing. Two aero-plane-type fins are flanged onto its surface and together with the strut gain rotational energy from the forward propeller. The unit is designed in such a way to allow the mounting/dismounting of the underwater propulsion module while the vessel is afloat. Optionally, a proper underwater mounting is possible for offshore structures.

The following items are installed in the propulsion module (underwater part):

- Propeller shaft
- Shaft sealing system

- Bearing system
- Emergency sealing system
- Shaft blocking system
- Propulsion motor
- Bilge system/pumps
- Alarm and monitoring sensors for motor, bearings and sealing systems.



Steering gear plate

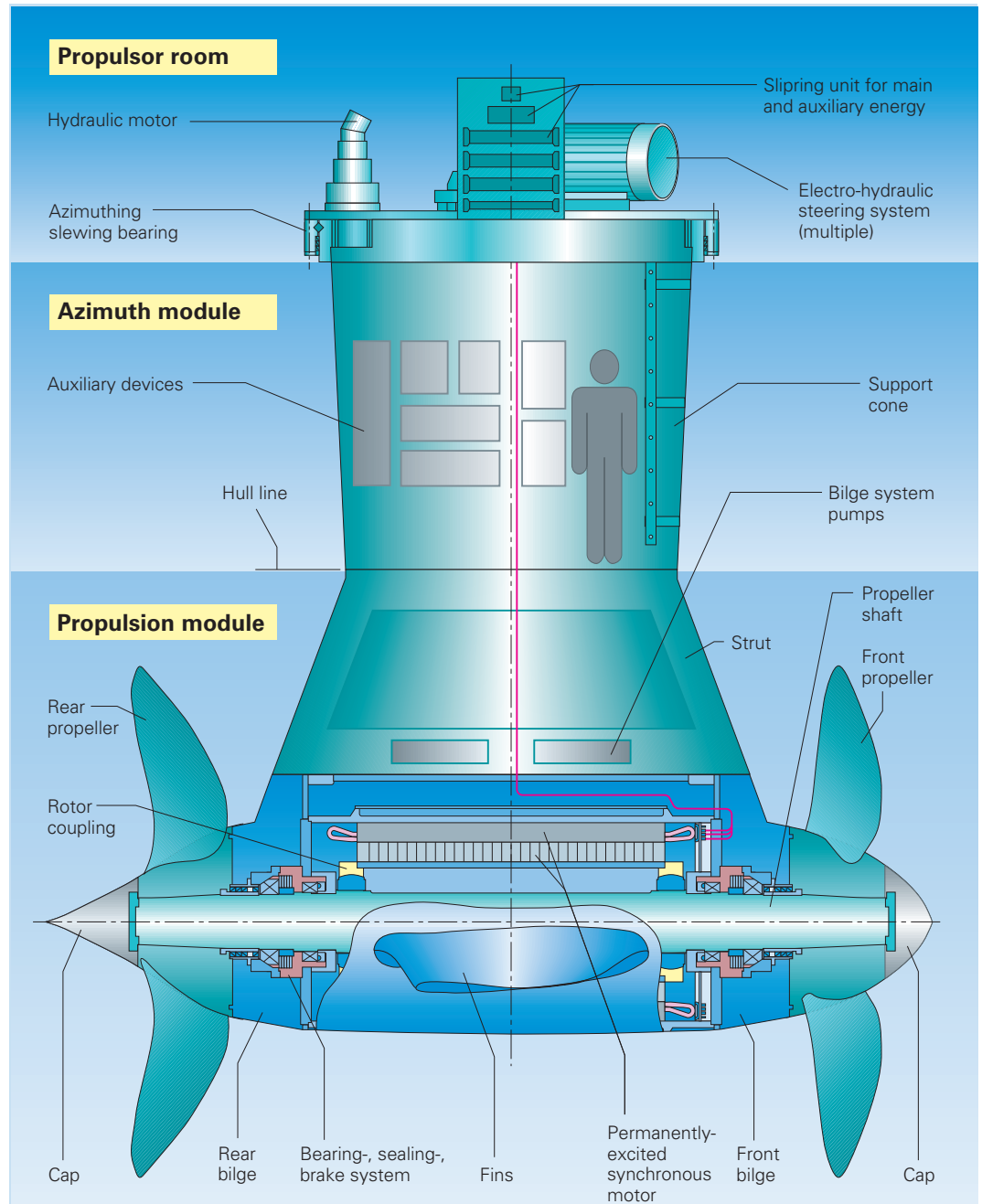

# Electrical drive system

Only the permanently-excited synchronous motor is capable of satisfying the rigorous technical and economic requirements placed on the drive system.

In this machine, the magnetic flux is generated by high-performance permanent magnets. These well-proven standard magnets are arranged on the rotor of the motor and take the place of conventional excitation windings and auxiliaries, such as sliprings and rectifiers. This arrangement makes it possible to significantly reduce the volume and weight of the power unit. A further advantage of the permanently-excited motor is its enhanced efficiency resulting from the elimination of core, winding and ventilation.

Continuous excitation causes the motor to behave as an under-excited synchronous machine. Self-commutated converters such as the cycloconverter have been selected for optimum economic and technical performance. To suit the given load requirements, the **SSP Propulsor** will be available with cycloconverter.

The active elements of the rotor, i.e. laminated yokes and magnetic elements, are arranged on the external surface of the hub. The rotor will be banded and completely impregnated for maximum strength.

As the working flux of the motor is constant with respect to time, small core losses are generated in the rotor surface as a result of mutual induction in direct proportion to rotor speed. These losses are dissipated by convection across the air gap, laminated stator core and housing directly to the surrounding seawater.

The entire rotor structure is mounted directly on the propeller shaft.

The electrically active parts of the stator do not differ significantly from those of a conventional synchronous motor. In this design, however, the stator is reduced to the laminated stator core and windings. The completely impregnated stator is shrunk directly into the lower housing for maximum heat dissipation.

The winding overhangs of the stator windings are cast with a heat-conducting compound, so as to establish a firm mechanical connection with the lower housing and achieve low heat resistance. Here, too, all current-induced heat losses will immediately be dissipated to the surrounding seawater.

The motor will be designed with one or two independent winding systems according to the demands placed on the propulsion system. The individual

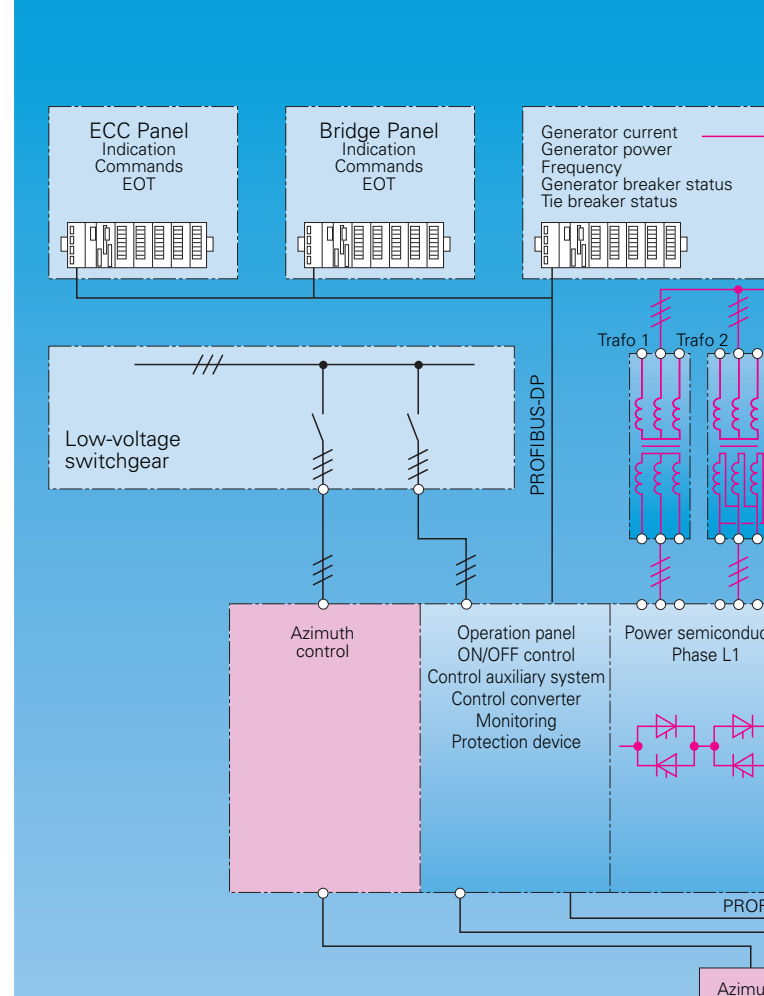

system windings are finished into a star configuration. For connection of the supply cables, the remaining 3 or 6 winding ends are brought out into the stern of the lower housing via a cable duct. Terminals inside the lower housing will be avoided.

By reducing the diameter of the motor the design measures have made it possible to meet the hydrodynamic demands. In comparison to a conventional synchronous motor, the diameter of a permanently-excited motor can be reduced by 40%, without increasing the length of the active elements in the axial direction. At the same time, a weight reduction of 15% can be achieved.

The supply cables between converter and propulsion motor will be short-circuit tested and installed accordingly. The stator current is transferred by sliprings, also used for the transmission of monitoring signals from the motor and the mechanical equipment. Thermal monitoring of the stator winding is achieved by means of built-in standard resistance temperature detectors.

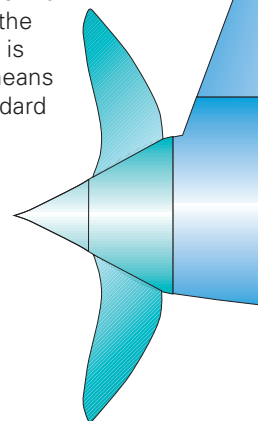

# Technical data

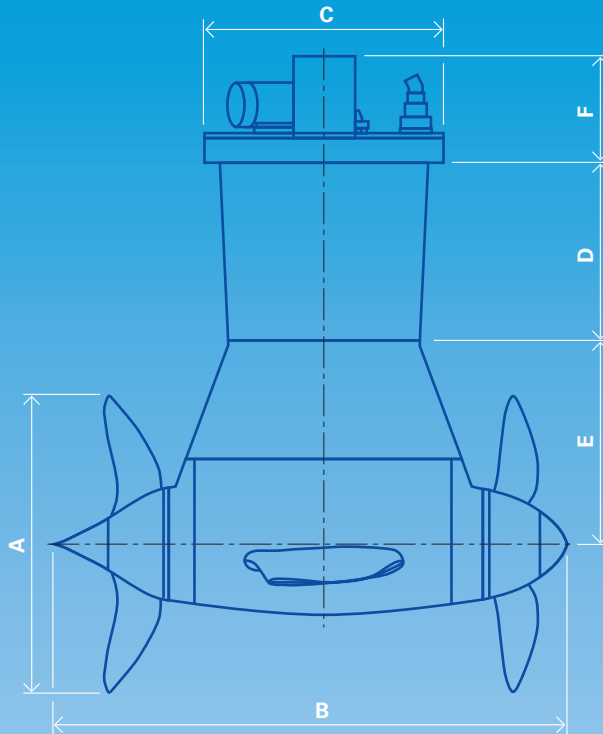
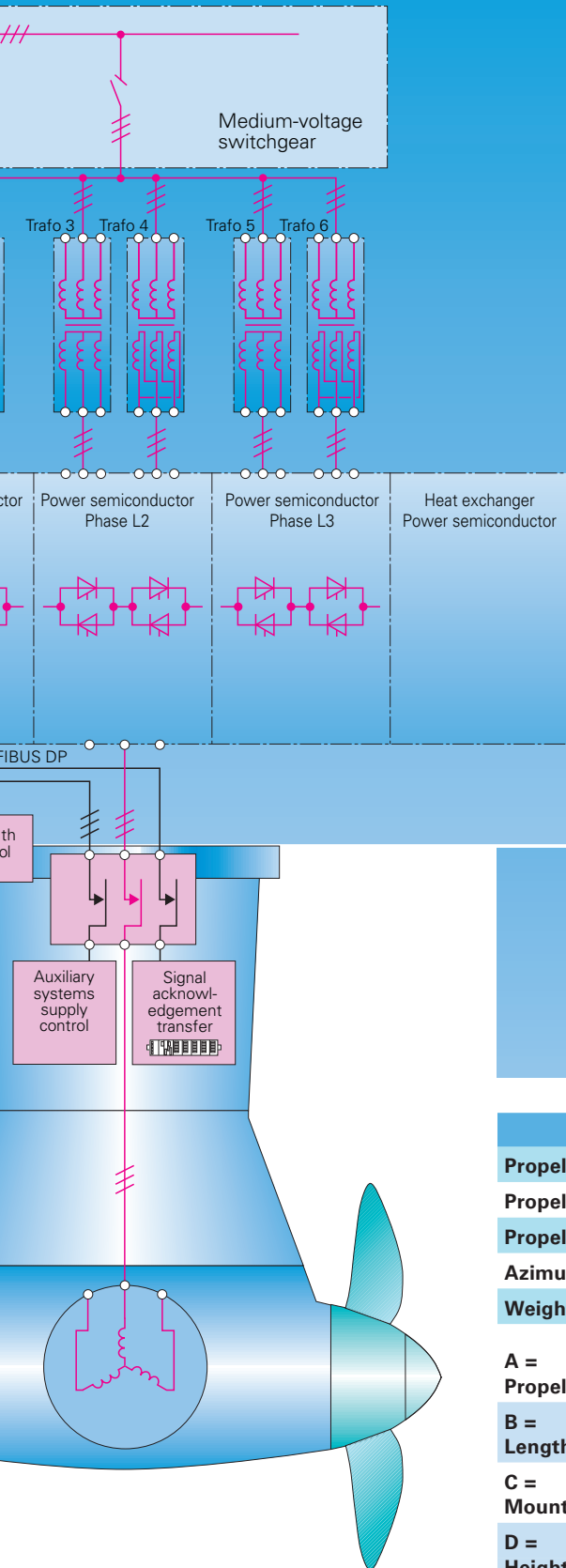

	Unit	SSP5	SSP7	SSP10	SSP14	SSP18	SSP20
<b>Propeller power</b>	P <sub>p</sub> [kW]	5000	7000	10,000	14,000	18,000	20,000**
<b>Propeller speed</b>	n <sub>p</sub> [rpm]	190	170	160	150	145	130
<b>Propeller torque</b>	M <sub>p</sub> [kNm]	251	393	597	891	1185	1469
<b>Azimuth speed</b>	n <sub>a</sub> [rpm]	2	2	2	2	2	2
<b>Weight (twin version)</b>	mssp [t]	95	125	170	230	280	310
<b>A = Propeller diameter</b>	[mm]	3750	4250	4750	5250	5800	6250
<b>B = Length propulsion module</b>	[mm]	6625	7500	8380	9260	10,590	11,000
<b>C = Mounting flange diameter</b>	[mm]	3000	3500	3800	4200	4800	5000
<b>D = Height support cone</b>	[mm]	2100 – 2750 (standard height 2500)					
<b>E = Height propulsion module*</b>	[mm]	2100	2975	3325	3675	4000	4375
<b>F = Installation height propulsion room</b>	[mm]	1630	1675	1720	1760	1800	1850

\* Valid for standard propeller diameters.

\*\* Higher propeller power available on request. Dimensions are based on standard types. Adaptions will be made to project requirements.



# The SSP Propulsor can optimize your vessel design

## Drive concepts

Due to electrical characteristics identical to those of a conventional synchronous motor, the permanently-excited motor can easily be integrated into established drive system concepts without restriction. The availability improvement achieved in this way will result in significantly increased security of the entire vessel.

## Installation

As our drawings show, **SSP Propulsor** offers major vessel design benefits.

Diesel-mechanical drive systems are the most space-consuming marine propulsion systems. Because of the layout dictated by the main diesels, gears, shaft line systems, rudders and so on, all other machinery and the hull shape have to be designed accordingly.

Diesel-electric drive systems allow more design flexibility because there is more latitude in the placing of the diesels in the engine room. However, the major disadvantages of shaft line systems, rudders, etc. remain and the hull shape is still largely predetermined.

Only podded azimuthing diesel-electric propulsion systems offer a maximum of flexibility of hull and engine room design, resulting either in extended cargo capacity at given vessel dimensions, or reduced vessel dimensions as compared with the alternatives already mentioned.

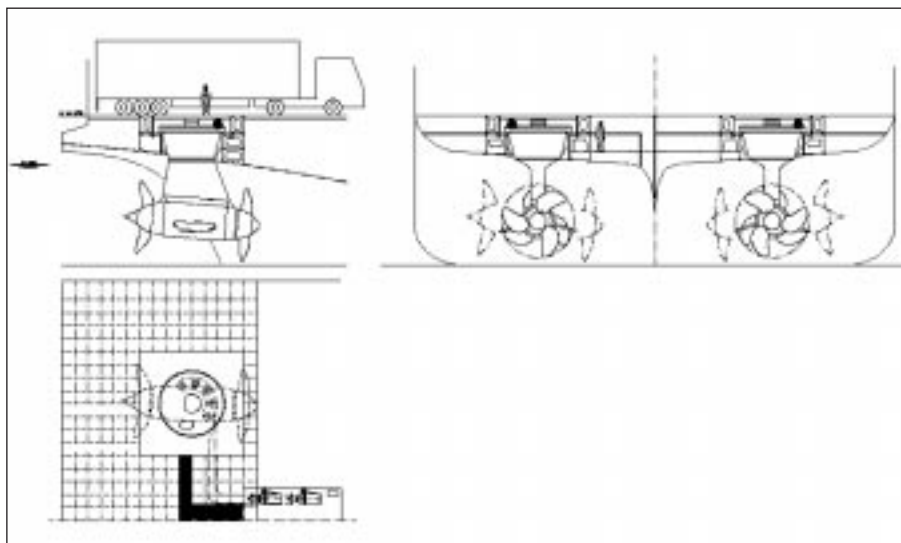
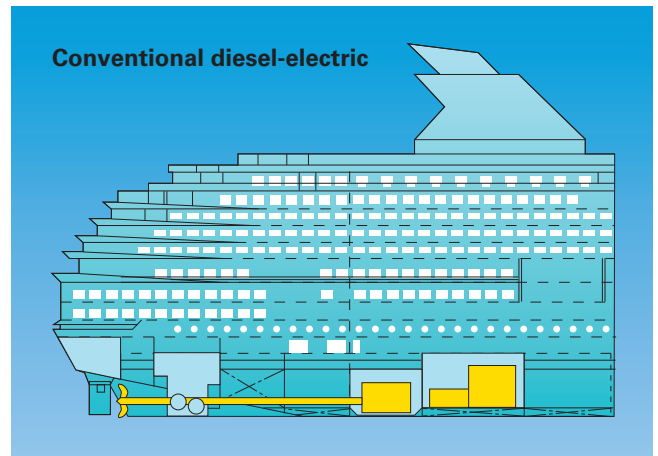
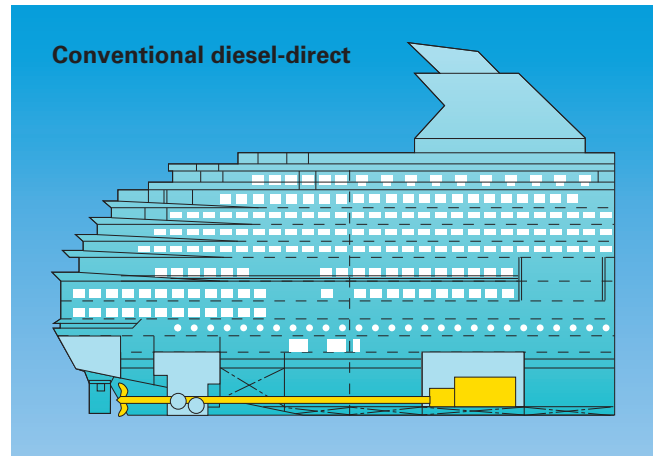
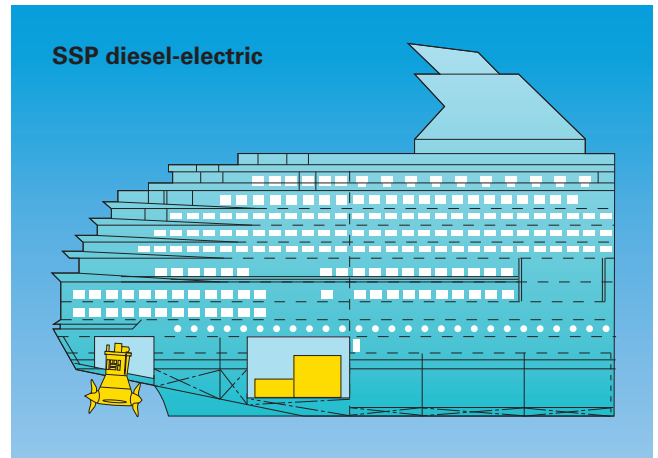

## Convincing advantages

More usable aft deck space is available due to the fact that a large-scale cooling system is not necessary. No disturbing noises are emitted by cooling fans etc.

All auxiliary units are located inside or on top of the **SSP Propulsor**. Therefore the designer has a greater scope for planning the aft ship.

The system is inclined to allow optimum water flow to the propellers. The **SSP Propulsor** and the design of the aft ship are matched for optimum hydrodynamic efficiency.



# References

The SSP proving its versatility  
in a variety of applications:



## **2 chemical product tankers**

*For Donsø Tank Rederi AB, Sweden  
1 unit SSP7 each tanker*



## **2 RoRo ferries**

*For TT-Line GmbH & Co, Germany  
2 units SSP10 each vessel*



## **2 heavy lift carriers**

*For COSCO, P.R. of China  
2 units SSP5 each vessel*

International patents pending  
© Siemens AG 2001  
All rights reserved

C O N S O R T I U M      S S P

---

## **SIEMENS**

Siemens AG  
Industrial Solutions and Services  
Marine Solutions, Podded Drive Systems  
P.O. Box 10 56 09  
D-20038 Hamburg  
Germany  
Tel.: +49 (40) 28 89-32 85  
Fax: +49 (40) 28 89-27 34  
E-mail: [marine.solutions@hbg.siemens.de](mailto:marine.solutions@hbg.siemens.de)  
[www.marine-solutions.de](http://www.marine-solutions.de)



SCHOTTEL GmbH & Co. KG  
Mainzer Straße 99  
D-56322 Spay  
Germany  
Tel.: +49 (26 28) 61-0  
Fax: +49 (26 28) 61-3 00  
E-mail: [info@schottel.de](mailto:info@schottel.de)  
[www.schottel.de](http://www.schottel.de)



Diagram showing overview of function units

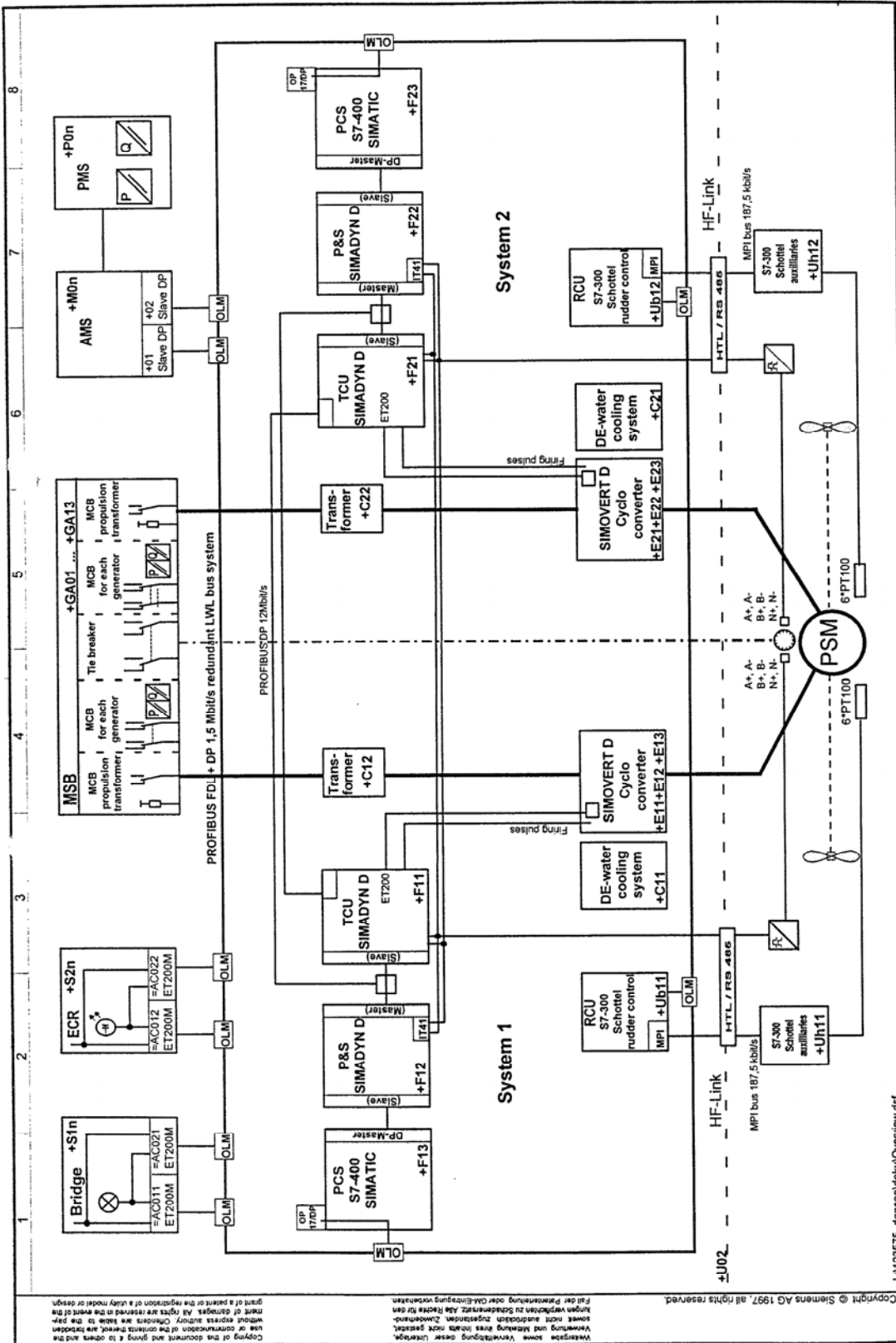

Copyright © Siemens AG 1997, all rights reserved.  
 Verwendete sowie Verwendungsrechte vorbehalten.  
 Soweit nicht ausdrücklich zugestanden, Zurechnungs-  
 Vermerk und Markenname sind nicht geschützt.  
 Alle Rechte vorbehalten. Alle Rechte für den  
 Fall der Patentierung oder Gebrauchsmarkens-  
 Anmeldung vorbehalten.  
 Copying of this document and giving it to others and the  
 use of communication of the contents thereof, are forbidden  
 without express authorisation. Copyrights are held in the  
 event of changes. All rights are reserved in the event of any  
 grant of a patent or the registration of a utility model or design.

L:\123575_donsoetank\Overview.dsf		Siemens AG	
Datum: 99-09-13	Bearb. Wieloska	ATD IS 3M Hamburg	
Gepr. Hoos	Overview of function units		
Zustand: /	SESC HULL 118 Donsoetank		
Ardenung: /	SIMAR DRIVE SSP		
	Urspr./Ers.f./Ers.d/E10231-K1016-S143 F4E Typicals 26.05.99 Wieloska		
	ATD IS3-123575		Blatt 1 Bl

Introduction to Standards for Marine Programmable Systems  
Copyright BSI 2007

## **Introduction to Standards for Marine Programmable Systems**

### **Ships and marine technology — Computer applications — General principles for the development and use of programmable electronic systems in marine applications<sup>[SR1]</sup>**

*Systems which include programmable electronic systems (PES) are not exact substitutes for the electromechanical systems and/or crew tasks which they replace. A new technology is involved, which can provide opportunities for integration of traditional system components (including crew tasks) and more complex behaviour. This allows increases in efficiency and safety through improved monitoring, better situational awareness on the bridge, etc. However, PES are complex products and, like all products, they can contain defects. These defects cannot be seen. Software does not respond to traditional engineering methods for the testing of soundness. The combination of complexity, replacement of a combination of mechanical and crew functions with computer hardware and software, and industry practice in developing and maintaining marine PES leads to a wide range of potential defects which cannot be guarded against by prescriptive standards.*

*The use of a PES in the management, monitoring or control of a ship may have several effects:*

- Potential to enhance the ability and efficiency of the crew;*
- Changes in the organization of work through the automation of lower-level tasks;*
- Integration of systems through use of several systems by one seafarer;*
- Shift in the role of the crew towards the management of many linked, complex PES;*
- Shift of the crew's perception of the ship to that presented by the interfaces of the PES;*
- Layers of embedded and/or application software interposed between the crew and the ship;*
- Physical interconnection of ship systems through the use of computer networks.*

*The overall effect of the use of PES is that the ship becomes one total system of inter-linked PES and crew which work together to fulfil the operator's business goals for the ship. In order for this total system to be dependable, both the design of the PES and the management of its use have to support the safe and effective performance of the crew as a critical component of the total system. Such a human-centred approach has to be based on a thorough knowledge of the particular skills, working environment and tasks of the crew using the PES.*

*In the traditional approach to maritime safety, ship systems are built to and operated against precise, prescriptive standards. These standards were developed in response to feedback about incidents or risky behaviour of previous ship systems. This approach is appropriate for relatively simple systems in a time of slow technical innovation. However, suppliers and operators nowadays want to innovate with complex, new solutions. In addition, the base technologies for PES are evolving very quickly. The assurance of dependability in this case cannot rely on knowledge of previous systems. The solution is for the developer and operator to assess the risks from and to the particular ship, its systems, crew and its operating philosophy, and to address these specific risks in the design and operation of the PES. Components of the system can then either be redesigned or operated in such a way as to minimize these risks. The quality of construction, operation and maintenance of the system to be sure of the achievement of a required level of dependability of the PES is also defined. This International Standard is based on best practice in PES development as stated in existing marine, electrical and electronic, IT, ergonomics and safety standards. It is not intended to replace any of these standards. It presents a synoptic view of the requirements of these standards as a framework of principles for the development of dependable PES.*

## **Product principles for marine PES<sub>[SR2]</sub>**

The PES shall be demonstrably suitable for the user and the given task in a particular context of use. It shall deliver correct, timely, sufficient and unambiguous information to its users and other systems. The hardware and software of the PES shall respond correctly throughout its life cycle. This can be achieved if the following principles are fulfilled by the PES and its associated elements throughout its life.

- P1 The PES shall be free from unacceptable risk of harm to persons or the environment.
- P2 In the event of failure the PES shall remain in or revert to the least hazardous condition.
- P3 The PES shall provide functions which meet user needs.
- P4 Functions shall be appropriately allocated between users and PES.
- P5 The PES shall be tolerant of faults and input errors.

- P6 The PES shall maintain specified levels of accuracy, timeliness and resource utilisation when used under specified operational and environmental conditions.
- P7 Unauthorised access to the PES shall be prevented.
- P8 The PES shall be acceptable to the user and support effective and efficient operation under specified conditions.
- P9 The operation of the PES shall be consistent and shall correspond to user expectations of the underlying process.
- P10 The interaction between the PES and the user shall be controllable by the user.
- P11 The PES shall support proper installation and maintenance, including repair and modification.

**Life cycle principles for marine PES<sup>[SR3]</sup>**

The successful realization and use of a dependable marine PES requires a systematic approach throughout the life of the PES. The key requirements for any approach which aims to meet the product principles given in above are described below.

- L1 All PES lifecycle activities shall be planned and structured in a systematic manner.
- L2 The required level of safety shall be realised by appropriate activities throughout the lifecycle.
- L3 User centred activities shall be employed throughout the lifecycle.
- L4 Verification and validation activities shall be employed throughout the lifecycle.
- L5 All parties involved in lifecycle activities shall have and use a Quality Management System.
- L6 Existing requirements for marine systems shall be taken into account throughout the lifecycle.
- L7 Suitable documentation shall be produced to ensure all PES lifecycle activities can be performed effectively.
- L8 Persons who have responsibilities for any lifecycle activities shall be competent to discharge those responsibilities.
- L9 The PES configuration shall be identified and controlled throughout the lifecycle.

Excerpts from Pod Quality Forum Document

# Common Quality Instructions

Version 2.0

13 September 2004

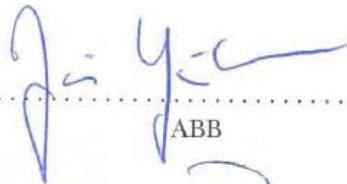

  
.....  
ABB

  
.....  
Rolls-Royce AB

  
.....  
Siemens

  
.....  
Schottel

  
.....  
DNV

## List of content

List of content .....	1
1 Introduction .....	3
2 Production phase quality instructions .....	4
2.1 General .....	4
2.2 Testing / Inspection .....	4
2.3 Materials .....	4
2.4 Manufacturing methods .....	4
2.4.1 Welding .....	4
2.4.2 Castings .....	4
2.4.3 Machining .....	5
2.4.4 Coating / Corrosion protection .....	5
2.5 Main components .....	5
2.5.1 Propeller and propeller shaft .....	5
2.5.2 Bearings .....	5
2.5.3 Sealing system .....	6
2.5.4 Pod housing .....	6
2.5.5 Propulsion motor .....	6
2.5.6 Steering gear .....	7
2.5.7 Slip ring unit .....	7
2.6 Sub systems .....	7
2.6.1 Lubrication systems .....	7
2.6.2 Cooling system .....	7
2.6.3 Drainage system .....	7
2.6.4 Hydraulic steering system .....	8
2.6.5 Auxiliary piping system and hoses .....	8
2.6.6 Monitoring and alarm system .....	8
2.7 Assembly and work shop installation .....	8
2.7.1 General .....	8
2.7.2 Assembly instructions .....	8
2.7.3 Electrical installations .....	8
2.7.4 Bolted connections .....	8
2.7.5 Shrink fit connections .....	9
2.8 Workshop acceptance testing .....	9
2.9 Final product .....	9
3 Post production phase quality requirements .....	11
3.1 Storage .....	11
3.1.1 General .....	11
3.1.2 Indoor storage .....	11
3.1.3 Outdoor storage .....	11
3.1.4 Long term storage .....	11
3.2 Transportation .....	12
3.2.1 Logistics .....	12
3.2.2 Transportation instructions .....	12
3.2.3 Documentation of deliveries .....	12
3.2.4 Confirmation of deliveries .....	12
3.2.5 Transport protection .....	12
3.3 Installation .....	13

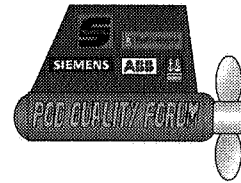

3.3.1	Safety .....	13
3.3.2	Pre-requirements .....	13
3.3.3	Supervision.....	13
3.3.4	Environment and protection.....	13
3.3.5	Equipment .....	13
3.4	Commissioning .....	14
3.4.1	Safety .....	14
3.4.2	Pre-requirements.....	14
3.4.3	Environment and protection.....	14
3.4.4	Connection and testing of systems.....	14
3.5	Harbour acceptance test.....	15
3.5.1	Pre-requirements.....	15
3.5.2	Functional tests .....	15
3.5.3	Oil replacement .....	15
3.6	Sea trial acceptance test .....	15
3.6.1	Pre-requirements.....	15
3.6.2	Monitoring.....	15
4	Operational phase quality requirements .....	17
4.1	Customer support .....	17
4.1.1	24-hours service .....	17
4.1.2	Certified service personnel .....	17
4.2	Life cycle management.....	17
4.2.1	Contingency plan (unexpected failures) .....	17
4.2.2	Spare parts .....	17
4.2.3	Modernisation / upgrading .....	18
4.3	Training.....	18
4.3.1	Crew training .....	18
4.3.2	Pod maker personnel training.....	18
4.4	Manuals .....	18
4.4.1	Operation instructions.....	18
4.4.2	Safety manuals.....	19
4.5	Maintenance .....	19
4.5.1	Scheduled maintenance program.....	19
4.5.2	Condition based maintenance .....	19
4.6	Monitoring.....	19
4.6.1	Local monitoring .....	19
4.6.2	Monitoring by inspections .....	20
4.6.3	Approval of monitoring system .....	20
5	Quality management.....	21
5.1	Quality system .....	21
5.2	Quality plan.....	21
5.3	Documentation .....	21

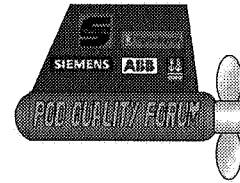

## ***3.5 Harbour acceptance test***

### **3.5.1 Pre-requirements**

- In order to secure the system functionality before tests, the pod manufacturer shall establish checklists specifying the pre-requirements before the harbour acceptance test can commence.
- In order to optimise the supplier's participation, the pod manufacturer shall require that a plan (time and resources) for harbour acceptance test is established by the ship yard. This plan is to be presented to the supplier in due time prior to the test.
- In order to make the tests efficient, the roles during the tests must be clear and communicated to all involved parties. Although this is coordinated by the yard, the pod manufacturer shall actively contribute to ensure this.

### **3.5.2 Functional tests**

- During the harbour acceptance test, a complete system functional test shall be carried out, in order to verify the systems prior to the sea trial acceptance test (see 3.6). The functional tests shall be carried out according to a procedure, specified by the pod manufacturer.

### **3.5.3 Oil replacement**

- Debris (particles) might have entered the system during testing. Hence, lubrication oil is to be replaced after the harbour acceptance test
- If adequate means are provided to supervise the debris content, the above may be waived when supervision results provides for it.
- This is to be communicated clearly to the yard in the applicable instructions.

## ***3.6 Sea trial acceptance test***

### **3.6.1 Pre-requirements**

- In order to secure the system functionality before tests, the pod manufacturer shall establish checklists specifying the pre-requirements before the sea trial acceptance test can commence.
- In order to optimise the supplier's participation, the pod manufacturer shall require that a plan (time and resources) for sea trial acceptance test is established by the ship yard. This plan is to be presented to the supplier in due time prior to the test.
- In order to make the tests efficient, the roles during the tests must be clear and communicated to all involved parties. Although this is coordinated by the yard, the pod manufacturer shall actively contribute to ensure this.

### **3.6.2 Monitoring**

- The first monitoring values from the unit in operation shall be recorded during sea trials. These will be the basis for further monitoring and for adjustments during sea trial acceptance test.



- The monitoring shall be carried out according to the pod manufacturer's specification.

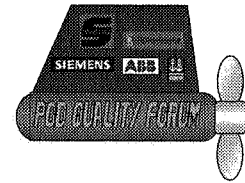

## **4 Operational phase quality requirements**

### **4.1 Customer support**

#### **4.1.1 24-hours service**

- In order to give the operators technical staff sufficient support in case of problems exceeding scope of manuals (and thereby prevent failures or unscheduled maintenance), the pod manufacturer shall have established a system for 24-hours service ("Hotline").

#### **4.1.2 Certified service personnel**

- The pod manufacturer shall ensure that certified service engineers are available within reasonable response time.
- Such personnel must be familiar with the pod specific requirements.
- The personnel shall undergo a certain amount of training, specified by the pod maker, prior to the certification.

### **4.2 Life cycle management**

#### **4.2.1 Contingency plan (unexpected failures)**

- In order to ensure that both maker and operator are aware of possible failures, the maker shall see to that a contingency plan can be provided. Such a plan shall be in form of an agreement between maker and operator.
- In addition to possible failures, the contingency plan shall include:
  - o Possible causes of failures
  - o Effect of failures
  - o Standard solutions to most likely or most critical problems that may arise.
  - o List of necessary spare parts (see 4.2.2)
- Contingency plan is normally to be based upon a Failure Mode Effect Analysis (FMEA).
- Necessary preparations shall be done at both maker and operator with respect to the optimisation of logistics, spare parts, training, definition of responsible personnel, etc.

#### **4.2.2 Spare parts**

- A list of necessary spare parts shall be available, and preferably a part of the contingency plan.
- Pod manufacturer (including sub-suppliers) and operator shall agree upon the necessary degree of availability for all spare parts, based on expected component lifetimes and a consideration of operational profile.

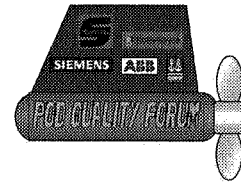

### **4.2.3 Modernisation / upgrading**

- In order to keep the pods in operation on the best technical standard and to guarantee the availability of spare parts to the operator, the pod manufacturer shall ensure that technical information regarding hardware and software updates is available.
- Pod manufacturer shall also recommend on proactive upgrading, in case of pending risks learned from other applications.

## **4.3 Training**

### **4.3.1 Crew training**

- In order to ensure that there are qualified people available to operate the pod system, the pod maker shall offer theoretical and practical training of the ships crew or owner/operators office staff.
- The training shall comprise function related lessons (for nautical, technical and office staff) held by manufacturers.
- Theoretical training can be given in makers or operators office, while practical training may be given directly on the system.

### **4.3.2 Pod maker personnel training**

- In order to ensure that qualified people are available from maker on site or on phone, the pod maker shall see to that proper training of service engineers and office staff at the makers service department is carried out.
- For service engineers the training shall include product & safety aspects.

## **4.4 Manuals**

### **4.4.1 Operation instructions**

- Pod manufacturer shall ensure that operation and maintenance instructions are available, by means of manuals. The manuals shall aim to give the operator the best possible overview of functionality and possible malfunctions of the system.
- The manuals shall give technical personnel detailed information about:
  - o The function of all systems and sub-systems
  - o How to react on failures
  - o How to maintain the systems
- The manuals shall give nautical personnel global information about:
  - o The main function of the major systems
  - o Recommendations on how to react on failures
- The manuals shall comprise graphical explanations showing what, when and how to do.

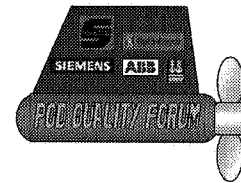

#### **4.4.2 Safety manuals**

- Safety items are of superior importance, and the pod manufacturer shall ensure that safety manuals are available on board, either as separate manuals or included in ordinary manual.
- A very compact *Bridge handbook* is recommended to be available for nautical staff, focusing on interaction of propulsion system and ship safety system. It shall give a short overview of possible consequences of possible failures, as well as recommended reactions.

### **4.5 Maintenance**

#### **4.5.1 Scheduled maintenance program**

- The pod manufacturer shall ensure that a plan defining maintenance and exchange intervals by time (e.g. classification periods) or operation hour intervals is available on board.
- The maintenance plan is to be defined from design and operational profile.
- The maintenance plan shall clearly define what maintenance item has to be executed at what time / operation interval, as well as who is carrying it out.
- The operator must be instructed by the pod manufacturer that maintenance work shall be traceable.

#### **4.5.2 Condition based maintenance**

- In order to ensure a high availability and prevent unexpected incidents, such as failures or breakdowns, the pod manufacturer shall ensure that the maintenance plan identifies the maintenance items that are not dependent from time/ operation intervals, but from machine condition. Condition based maintenance is also connected to the monitoring program (see 4.6).

### **4.6 Monitoring**

The intention for all the monitoring requirements is:

- Prepare data for condition based maintenance measures.
- Prevent unscheduled maintenance and breakdown.
- To allow condition-based maintenance or replacement of components.

#### **4.6.1 Local monitoring**

- The pod manufacturer shall see to that local monitoring of vital parameters is possible. E.g., such parameters are:
  - o Bearing condition / bearing lubricant condition
  - o Condition of propulsion motor (temperature)
  - o Vibration level (bearings)
  - o Leakage rate in sealings

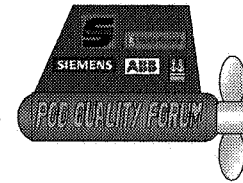

- The values from the local monitoring system shall continuously or regularly be recorded from the automation system or by visual read-out or measuring/gauging.
- Monitoring recordings/analysis shall be evaluated against given limitations by makers' experts.

#### **4.6.2 Monitoring by inspections**

- The pod manufacturer shall provide the necessary features in order to allow monitoring of slow-changing (mainly wear related) machine condition by visual checks. Such checks could be videoscope inspection or wear gauging.

#### **4.6.3 Approval of monitoring system**

- The monitoring system is to be approved by the pod manufacturer.
- It must be clearly communicated to the yard and ship operator that no additional monitoring system must be installed inside the pod without the approval of the manufacturer.

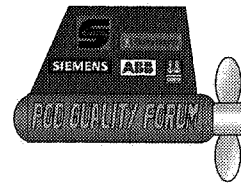

## **5 Quality management**

### **5.1 Quality system**

- The quality system shall comprise description of production inspection processes, assembly check lists as well as inspection procedures and records.

### **5.2 Quality plan**

- A project specific quality plan shall be established for each project.
- All major tests and inspections are to be carried out in own workshop or at sub-supplier shall be identified. Tests that are to be carried out during installation and commissioning shall be described as well.
- In the quality plan all main components of the pod shall be dealt with, describing the following:
  - o Test methods and specifying documents
  - o Where the tests shall be carried out
  - o Who is responsible for each task and who shall be informed

### **5.3 Documentation**

- The following documents shall be described in the quality plan:
  - o Production check lists
  - o Measurements and inspection records
  - o Records of all tests
  - o Classification certificates
- No document is valid without formal approval. Approval is to be clearly marked in document, including possible comments.
- Pod manufacturer is responsible for obtaining classification of the whole pod system, including components from sub-suppliers.



Siemens Safety Critical Information for SSP  
dated 8 November 2007

Rederi AB Donsötank

P.O. Box 19  
430 82 Donsö  
SWEDEN

Name	
Department	I&S OGM MAS LCM
Telephone	
Fax	
E-mail	
Your letter of	
Our reference	O-09300121-U-01/S1-si
Date	November 8, 2007

### MT Prospero, MT Bro Sincero & MT Evinco, here: Safety Critical Information for SSP

Dear

The following bulletin refers to the operating of your SSP drives:

Due to past inducement we advise you, not to dim the lights in the bridge console of the conning stations under the visibility level since this would render alarm lights invisible.

Sincerely yours,

#### Siemens AG

Division: Oil, Gas, Marine Solutions  
Head: Otto Soeberg, Head Business Admin.: Thomas Liegl  
Group: Industrial Solutions and Services  
Group Executive Management: Joergen Ole Haslestad, Group President;  
Bernd Euler, Hans-Joerg Grundmann, Joachim Moeller

Postal address:  
Siemens AG  
I&S OGM MAS LCM  
P.O. Box 10 56 09  
20038 Hamburg

Office address:  
Lindenplatz 2  
20099 Hamburg  
Tel: +49 (40) 28 89-0  
Fax: +49 (40) 28 89-22 10

Siemens Aktiengesellschaft: Chairman of the Supervisory Board: Gerhard Cromme  
Managing Board: Peter Loescher, Chairman, President and Chief Executive Officer; Heinrich Hiesinger, Joe Kaeser, Rudi Lamprecht,  
Eduardo Montes, Juergen Radomski, Erich R. Reinhardt, Hermann Requardt, Uriel J. Sharef, Peter Y. Solmssen, Klaus Wucherer  
Registered offices: Berlin and Munich; Commercial registries: Berlin Charlottenburg, HRB 12300, Munich, HRB 6684  
WEEE-Reg.-No. DE 23691322

SCF 2007-03

File: I:\projekte\LM7=Kunden\Donsoetank\SSP-Bulletin\_DONSOE\_071108.doc

DNV memo MTPNO867/KRESSE/22081-J-1102  
Changes made in DNV's requirements and procedures to approval,  
certification and shipboard installation and testing of pods  
and associated control and automation systems

**MEMO TO:**  
Whom it may concern

**MEMO NO. :** MTPNO867/KRESSE/22081-J-1102  
**FROM :** Machinery Ships in Operation  
**DATE :** 2007-05-21  
**PREP. BY :**

**Copy:**

**CHANGES MADE IN DNV'S REQUIREMENTS AND PROCEDURES TO APPROVAL, CERTIFICATION AND SHIPBOARD INSTALLATION AND TESTING OF PODS AND ASSOCIATED CONTROL- AND AUTOMATION SYSTEMS**

DNV has during the past years taken several steps to further evolve the classification activities related to complex machinery installations with its associated control and monitoring systems. Different measures have been initiated both in terms of work process alterations, extended training of surveyors and rule amendments as indicated below.

**Work process alterations, control and monitoring**

A completely revised Instructions to Surveyor, IS III D-7.2, was released in April 2004. These Instructions provide clearer assignment of responsibilities and improved quality assurance of both approval and certification of control and monitoring systems in general. The Instructions contain extensive check lists for approval and survey of control and monitoring systems. Together with amended rules they also provide guidelines on expected contents of certification survey test programme.

In addition, DNV has during the recent years turned the focus more towards multi-disciplinary handling of cases, and are currently running pilot projects on organising complex projects with a new co-ordinator position – System project manager with a specific job-instruction

Further, the ICT tools are developed and improved to facilitate rapid and stable sharing of documentation on the intranet as well as implementation of a new production system (Nauticus) providing a common electronic access to all relevant project information to the whole DNV organisation.

**Training, control and monitoring**

A course was developed and made mandatory in 2004 for all approval engineers and surveyors involved with approval and certification of control and monitoring systems. The main focus in the course is the work process related to certification of control and monitoring systems and experience exchange related to i.a. technical and procedural challenges.

The Veritas Qualification Scheme Class ensures that relevant personnel have undertaken necessary training related to handling control and monitoring systems.

In addition, a course covering electrical installations has been introduced and has been attended by many of the electrical surveyors.

### **Rule, control and monitoring**

- The Rules for control and monitoring systems have been developed on several areas, and have during the recent years been (or is about to be) amended on i.a. the following areas: Quality assurance of software development and change handling
- Response to failures
- Alarm handling and presentation
- User interface / man – machine interface
- Integrated systems / network challenges
- Independency between systems and verification of back-up functions

(Some Rule References of relevance:

Pt.4 Ch.9 Sec.1

A 300 Alterations and additions

Requiring a controlled and traceable way of handling SW changes during the operational phase.

Pt.4 Ch.9 Sec.1 D Tests and Pt.4 Ch.9 Sec.2 C Back – up functions (rule proposal)

Verification of emergency means of control of essential systems

Pt.4 Ch.9 Sec.3 System Design (rule proposal)

Clarified requirements for independency between safety functions and other functions

Pt.4 Ch.9 Sec.4 System Design (rule proposal)

Improved requirements for data communication links including wireless communication

Pt.4 Ch.9 Sec.6 User interface (rule proposal)

Major update of the requirements )

The steering gear requirements have been strengthened i.a. on the following issues:

- Identification of failure modes in a separate document (Pt.4 Ch.14 Sec.1A)
- Response to failure in the feedback-loop preventing unexpected rudder behaviour upon feedback failure (Pt.4 Ch.14 Sec.1A)

## **Rules, mechanical**

Also the rules related to the mechanical aspects, given in Pt.4 Ch.5, of the pods have been subject to further evolvement as outlined below.

### **Jan.01**

The manufacturer shall submit information about any operational limitations, design criteria and load assumptions (A200).

Leakage detection for slewing seal at hull penetration has been added (B504).

Function testing is required for all hydraulic systems (D103).

Detailed requirements with respect to static and dynamic stresses in pod stay (B501).

Extended requirements for lubricating oil systems (B800).

Azimuth thrusters shall be mounted in a watertight compartment unless the penetration through the hull is situated above the deepest loaded waterline (F104).

### **July 05**

For single pod installations the steering gear torque capacity should be 2x100% (B402).

The thrusters/pods shall be prevented from sudden turning in the case of power failure, failure in the steering control system or any other single failure, except failure in steering column and support bearings (B404).

Sub-assemblies carried out the yard to be verified by surveyor (H103).

Extended requirements for seatrial testing (I100).

More detailed requirements for documentation for steering gear and for documentation of electrical motor control system for thrusters driven by electric motor (A200).

The following rule paragraphs where introduced:

B103: shielding of POD internals

B104: hydraulic components (and for piping arrangement)

B105: cooling of podded thrusters

B202: duplication of shaft seals for single unit installations

B203: rope guard

B416: control system for electro mechanical steering gear with respect to acceleration and shock load

B417: rating for electro motor driving the steering gear

B505: bilge system for podded thrusters

B802: separate lubrication systems for installations with a limited volume of oil sump

E105: duplication of sensors not easily replaceable

F104: boundary to sea

F203: steering gear emergency power supply

Guidance note has been added covering:

B803: lubrication oil cleanliness

**July. 07 (coming into force)**

Under Sec.1 E300, **TMON** for podded propulsion has been withdrawn.

**Rules, electro**

The Rules for Electrical Propulsion in Pt.4 Ch.8 have been modified as follows:

**2001:**

Frequency converters certification, requirements modified:

- Added requirements to protection and monitoring in line with requirements in Pt.4 Ch.5/Pt.4 Ch.9
- Added/clarified requirements to testing of converters and scope of verification work.

- o0o -