

Boatyard invoices for works carried out to *Purbeck Isle's* hull during 2011 maintenance period and the out of water emergency repairs undertaken in December 2011 and February 2012

Restoration and Refurbishment Specialists  
Boat Storage and Emergency Lift  
Builders of Yachts and Boats in Timber GRP or Epoxy  
Approved 'West System' Osmosis Centre

Invoice No [REDACTED]

[REDACTED]  
[REDACTED]  
[REDACTED]  
Email:

Tel: [REDACTED]

Mobile: [REDACTED]

7 November 2011

Resent 23 April 2012

Resent 25 January 2012

### PURBECK ISLE

- ▲ Stop and caulk hull below wl as required (approximately 80% re-stopped)
- ▲ Replace tingles as required
- ▲ Renew shodding to pot pad (approximately 3mtr x 0.8mtr)
- ▲ Repair planking and frame fastenings starboard side aft of pot pad to previous repair
- ▲ Remove and repair margin board adjacent to pot hauler
- ▲ Supply 2 tins of underwater primer

Sub Total [REDACTED]

Vat @ 20% [REDACTED]

**Total** [REDACTED]

Less cheque received 25 January 2012 - [REDACTED]

Less cheque received 27 February 2012 - [REDACTED]

Less cheque received 13 March 2012 - [REDACTED]

Less cheque received 25 April 2012 - [REDACTED]

Total Received - [REDACTED]

### Please Note

We would advise you that the repair to the starboard planking should be removed at a later date and planking replaced and extended to enable it to be supported by existing frames.

**\*When making a payment please ensure you include a reference**

### Direct payment details:

Sort Code [REDACTED]

Acc No [REDACTED]

☺ With thanks for your custom. ☺

Tel: [REDACTED] or Mobile: [REDACTED]

Company No [REDACTED]

Vat Reg No [REDACTED]

Title to the goods remains with [REDACTED] until full payment is received  
Payment due 7 days from date of invoice



50580

Name: [Redacted]

Address: [Redacted]

[Redacted]

Email: [Redacted]

Contact Nos: [Redacted] [Redacted]

Name of Vessel: *parbeck isle*

Start Date ..... End Date ..... Long Term .....

Length: ..... Crane Weight: ..... Out  In

Terms - Monthly  Weekly  Work Required

Pressure Wash: ..... Anti-Foul: .....

Date	Name	Hrs	Works	Parts
24/10	R	5 1/2	re-caulk +	2 x 25 Paint
24/10	T	5 1/2	Stopping in	3 x Saba.
25.10	R	7 hrs	caulking	Douglas fir
25.10	T	7 hrs	caulking	12 kilo Putty
25/10	RT	4 1/2	caulking + Stopping	2 kilo Red lead
25/10	RT	2	"	Tin 2 hrs. Sanding
25/10	RT	2	"	"
25/10	R	6 1/2	Remove paint + Shredding	"
25/10	T	4 1/2	caulking + Stopping	"
1/11	R	2 1/2	tingles	"
2/11	"	5'	Repairs	"
2/11	"	5'	Remove Shredding Se.	Repair all Steel
1-11	-	4 hrs.	.	"
			71.5.	

[Redacted] [Redacted] [Redacted] [Redacted] [Redacted] [Redacted]



Title to the goods remains with [Redacted] until full payment is received.

Tel/Fax [Redacted]  
Mobile [Redacted]  
Company No [Redacted]  
Vat Reg No [Redacted]

Invoice No [Redacted]

[REDACTED]  
Restoration and Refurbishment Specialists  
Boat Storage and Emergency Lift  
Builders of Yachts and Boats in Timber GRP or Epoxy  
Approved 'West System' Osmosis Centre

[REDACTED]  
Invoice No [REDACTED]

[REDACTED]  
[REDACTED]  
[REDACTED]  
Email:

Tel: [REDACTED]

Mobile: [REDACTED]

31 January 2012

Resent 23 April 2012

**PURBECK ISLE\_12 Dec**

- ▲ Remove 3 sections of pot pad
- ▲ Refasten plank to existing frame with new fastenings
- ▲ Re-cork as required
- ▲ Re-instate pot pad

Sub Total £210.00

Vat @ 20% £42.00

**Total £252.00**

**\*When making a payment please ensure you include a reference**

**Direct payment details:**

[REDACTED]  
Sort Code [REDACTED]

Acc No [REDACTED]

☺ With thanks for your custom. ☺

Title to the goods remains with [REDACTED] until full payment is received  
Payment due 7 days from date of invoice

[REDACTED]  
Tel: [REDACTED] or Mobile: [REDACTED]  
Company No [REDACTED] Vat Reg No [REDACTED]



*INVOICE*

Name:

Address: .....

Email: .....

Contact Nos: .....

Name of Vessel: *Purbeck Isle*

Start Date ..... End Date ..... Long Term .....

Length: ..... Crane Weight: ..... Out  In

Terms - Monthly  Weekly  Work Required

Pressure Wash: ..... Anti-Foul: .....

Date	Name	Hrs	Works	Parts
12/12/11	R	2 1/2	find leak + re-caulk + secure plank back	
12-12-11	T	2 1/2	"	
			Remove 3 sections of Pet Pad	
			Re-hunter sprung plank to existing	
			frame with new fastenings	
			Re-caulk as required	
			Re-install Pet pad	
			sub	£
			vat	£
			total	£

Title to the goods  
remains with   
 until full  
payment is received.

Tel/Fax   
Mobile   
Company No   
Vat Reg No

Invoice No

Restoration and Refurbishment Specialists  
Boat Storage and Emergency Lift  
Builders of Yachts and Boats in Timber GRP or Epoxy  
Approved 'West System' Osmosis Centre

Invoice No

Email:

Tel:

Mobile:

14 March 2012

Resent 23 April 2012

**PURBECK ISLE\_Feb**

- ▲ 23.12.11  
Emergency repair to vessel on drying grid in Weymouth Harbour
- ▲ 22.02.12 – 23.02.12  
Repairs to vessel at Portland Marina, manufacture and fit tingles from customer supplied copper sheeting
- ▲ Re-stop as required
- ▲ Fit nylon sheathing to pot pad
- ▲ Supply 3 x 2.5lt tins of anti-foul

Sub Total

Vat @ 20%

**Total**

**\*When making a payment please ensure you include a reference**

**Direct payment details:**

Sort Code

Acc No

☺ With thanks for your custom. ☺

Title to the goods remains with [redacted] until full payment is received  
Payment due 7 days from date of invoice

Tel: [redacted] or Mobile: [redacted]  
Company No [redacted] Vat Reg No [redacted]



Name: [Redacted] .....

Address: .....

Email: .....

Contact Nos: .....

Name of Vessel: PERBEACKED ISLE .....

Start Date ..... End Date ..... Long Term .....

Length: ..... Crane Weight: ..... Out  In

Terms - Monthly  Weekly  Work Required

Pressure Wash: ..... Anti-Foul: .....

Date	Name	Hrs	Works	Parts
23/12	TIM	2	CORKING ON receiving & stoping - 4 hrs.	
11	JERRY	2	SLIPWAY	
22/2	TIM	1		200 FAN INWOOD
22/2	RYAN	2 1/2		3 TURBS. SIKKA.
23/2	JER	5	CORKING BLACK ON POT PAD.	1/2 kilo Bronze.
23/2	TIM	5	" " "	3 + Anti Sealing
23/2	<del>Will</del>	<del>2 1/2</del>	CORKING	
23/2	Will	2 1/2	" "	
23/2	R	2 1/2	" "	
22/2	will	1/2	making red lead	

4 hrs

Title to the goods remains with [Redacted] until full payment is received.

Tel/Fax [Redacted]  
Mobile [Redacted]  
Company No [Redacted]  
Vat Reg No [Redacted]

Invoice No [Redacted]

Self-certification declaration form



**ANNEX 2**

**THE FISHING VESSELS (CODE OF PRACTICE FOR THE SAFETY OF SMALL FISHING VESSELS) REGULATIONS 2001**

**ANNUAL SELF CERTIFICATION (Owner to verify and sign in spaces below that vessel continues to comply with the requirements of the Code and retains a copy on board for inspection)**

**Name of Owner** .....

**Address of Owner** .....

.....

.....

**Name of Vessel**.....

**RSS No**..... **Length Overall** .....

**Registered Length** ..... **Date of Registration** .....

**Hull Identification No**..... **Mode(s) of Fishing** .....

**Port letters and number**.....

I HEREBY CERTIFY, in respect of the above named vessel, that:

- i. The safety equipment has been checked in accordance with the attached checklist;
- ii. Such safety equipment carried is in accordance with the requirements of the Code;
- iii. Such safety equipment has been properly maintained and serviced in accordance with manufacturers' recommendations;
- iv. Where applicable a risk assessment\* of work activities and duties has been completed in accordance with the Merchant Shipping and Fishing Vessels (Health and Safety at Work) Regulations 1997;

\*The health and safety risk assessment is written - Yes/No (delete as appropriate)

**1<sup>st</sup> Signature of Owner** ..... **Date**.....

**2<sup>nd</sup> Signature of Owner** ..... **Date**.....

**3<sup>rd</sup> Signature of Owner** ..... **Date**.....

**4<sup>th</sup> Signature of Owner** ..... **Date**.....

**5<sup>th</sup> Signature of Owner** ..... **Date**.....

Under 15m Fishing Vessels Survey/Inspection aide-mémoire

OTHER RELEVANT ITEMS – NON MANDATORY - RECOMMENDED			
	Y	N	NA
Hull			
Stability, condition of vessel			
Hull condition, external, internal			
Mooring and anchoring arrangements			
Decks			
Watertight hatches/coamings			
Bulwarks condition and height			
Freeing port areas – clear of obstructions/blockages			
Area recommended to be minimum 3% of Bulwark area			
<b>REMARKS</b>			
Wheelhouse/Cabin			
Windows, condition			
Doors, condition			
Record of LSA equipment examined			
Crew have received appropriate onboard training			
Instructions for on-board maintenance of LSA are on board. Inspect any immersion suits, thermal protective aids etc.			
Table or curve of residual deviations for magnetic compass may be provided			
Operational and, where appropriate, maintenance manuals for all navigational equipment provided			
Emergency instructions available for each person on board. Copies of suitably up-dated muster list may be posted in conspicuous places and in a language understood by all persons on board and posters or signs in the vicinity of survival craft and their launching stations as applicable			
As appropriate, the magnetic compass, gyro compass, radar installation, automatic radar plotting aid, echo-sounding device, speed and distance indicator, rudder angle indicator, propeller rate of revolution indicator, variable pitch propeller pitch and operational mode indicator. Automatic identification system, voyage data recorder, ECDIS, GPS.			
<b>REMARKS</b>			

COMPLETION OF SURVEY	
Should there be any doubt before completion of the survey/inspection contact the local Marine Office or Principal Fishing Vessel Surveyor for advice	
DECAL (or equivalent) issued or endorsed;	
Record of Equipment (check list) left with owner	
<b>REMARKS</b>	

	<b>UNDER 15 METRE FISHING VESSELS SURVEY/INSPECTION AIDE-MEMOIR</b> (Based on MSN 1813)		Doc No <b>MSF 5549</b>
	Name of Vessel	Date	Revision 1/10/07

CERTIFICATES AND RECORDS	YES	NO	N/A
	Validity of DECAL		
Self Certification form signed annually by the owner			
Validity of Certificate of Registry Note: change of ownership and/or modifications to the vessel such as change of length, engine etc. will require that the Certificate of Registry be renewed/amended			
Validity of Crew Training Certificates Basic Health and Safety Basic Sea Survival Basic Fire Fighting Basic First Aid Safety Awareness and Risk Assessment (if applicable) Voluntary Training currently funded free by DFT/Seafish Navigation Watchkeeping Engine Room Watchkeeping Stability Awareness Radio Licence (Contact 0207 981 3131 or 0300 123 1000)			
One crew holding:- Short Range Radio Certificate (Area A1) Restricted GMDSS (Area A2)			
Validity of servicing certificates for Fire Appliances Life Rafts Etc			
Risk Assessments Copies on board/available in Risk Assessment folder Note: change of ownership or change of mode of fishing will require amended/new Risk Assessments Any new equipment fitted meets current rules/fit for purpose etc.			
Has any fire occurred on board necessitating the operation of the fixed fire-extinguishing systems or the portable fire extinguishers since the last survey. Any requirements for Concentrated campaign or inspection have been confirmed – see any separate instructions			



INSPECTION ITEMS REQUIRED		OPEN VESSELS	DECKED VESSELS
Open Vessels		Under 7 m	7 to 12 m
Under 7 m Registered Length		Under 7 m	7 to 12 m
7 m to 12 m Registered Length		Under 10 m	10 to 12 m
Decked Vessels		Under 10 m	10 to 12 m
Under 10 m Registered Length		Under 10 m	10 to 12 m
10 m to 12 m Registered Length		Under 10 m	10 to 12 m
All Vessels		Under 10 m	10 to 12 m
12 m RL to 15 m Overall Length		Under 10 m	10 to 12 m
Lif jackets, with lights	1 per person	±	±
Liferafts ± Recommended		±	±
EPIRB ± Recommended		±	±
Lifebuys (1 with 18 m buoyant line)	2* 2* 2* 2* 2*	±	±
2* or 1 Lifebuoy (with 18 m buoyant line) + 1 Rescue Quoit		±	±
Parachute Flares	2 3 3 3 3 3	±	±
Hand held flares	2 2 2 2 2 2	±	±
Smoke Signal (buoyant or hand held)	1 1 1 1 1 1	±	±
Multi purpose Fire Extinguisher (Rating 5A/34B) *(if inboard engine)	1* 1 1 1 1	±	±
Fire Bucket + lanyard	1	±	±
Gas Detector		1	1
Fire Blanket (if galley or cooking area)	1	1	1
Smoke Alarms (Accom & Engine spaces)		Y	Y
Fire Pump and hose	1 1 1 1 1 1	±	±
or Fire Bucket + lanyard	1 1 1 1	±	±
or Fire Bucket + lanyard + 1 Multi purpose extinguisher (5A/34B) + Fixed fire fighting system for machinery space		Y	Y
Multi purpose Fire Extinguisher for oil fire (Rating 13A/113B) – See also Note 1		1	1
VHF Radio Fixed (DSC) or Hand Held	1	1	1
Bilge Pump	1 1 1 1 1 1	±	±
Bilge Alarm	1	1	1
Bailer		1	1
Navigation Lights and Sound signals	1	1	1
Radar Reflector	±	±	±
± Recommended for Wood/GRP vessels		±	±
Anchor and Cable/Warp	1	1	1
Compass	1	1	1
Waterproof Torch	1	1	1
Medical Kit	1	1	1
Stability Book ± Recommended		±	±

1 = Number to be supplied, 0 = not required, \* = Alternative  
 Y = Required, ± = Recommended, NA = Not Applicable

Note 1; for portable fire extinguishers, if a larger extinguisher is too cumbersome then small or smaller extinguishers may be substituted provided that the sum of the substitutes equals the total requirement of the larger extinguisher.

Check with Code requirements for any variations which may be allowed

SURVEY/INSPECTION – MANDATORY ITEMS		Y	N	NA
Lif jackets (inc. whistles, retro-reflective material and lights)				
Inflatable lifejackets to comply with BS EN 396 or 399, auto inflation and 150 Newtons buoyancy				
Each inflatable liferaft, the hydrostatic release unit and/or float-free arrangements. Note: reduced strength HRU may be used for smaller Liferafts. Annual service as required				
Lifebuys, self-igniting lights, self-activating smoke signals and buoyant lines, correctly marked with name/POR and reflective tape				
Parachute flares in date				
Hand-held flares in date				
Smoke signal/s in date				
Portable and non-portable fire extinguishers – correct type, condition, adequately maintained (annual service), location				
Fire Blanket, in galley if applicable				
Fire pump/s, Fire main, Hydrants, hoses and nozzles, Each pump, operated separately - jet of water produced at any part of the ship whilst required pressure is maintained in fire main				
Fire bucket with lanyard as applicable				
Fixed fire fighting system for machinery spaces, as appropriate, and means of operation clearly marked				
Fixed fire fighting system for machinery: CO2 capacity has been checked. Distribution pipework proved clear				
Examining and testing Fire detection and alarm system, if fitted				
Examining and testing Gas detection and alarm system, if fitted				
Bilge pumping – test of bilge pump/s				
Bilge alarms – if watertight bulkhead require 1 in Fish Room and 1 in Machinery space				
Navigation lights, shapes and sound signalling equipment				
Charts and nautical publications necessary for intended voyage available and up-dated.				
Radar Reflector condition, if applicable				
Operation of two-way VHF radiotelephone apparatus				
Safety of operation of fishing gear, winches, wires, blocks, nets, lines etc. (LOLER & PUWER Regs)				
Anchor and cable/warp, condition				
REMARKS				

OTHER RELEVANT ITEMS – NON MANDATORY – RECOMMENDED		Y	N	NA
Machinery Spaces				
Main and Auxiliary engines, condition, guards, exhaust, no exposed high temperature surfaces, fuel lines				
Bilges, condition, no oil being pumped overboard				
Condition of pipework, securing clips, skin fittings, sea cocks and their ease of operation				
Electrical cables – condition, securely clipped, electrically safe				
Batteries, condition				
Bulkheads, frames, condition				
Fire doors, flaps etc. condition				
Steering gear, condition, operational test				
Record of Planned Maintenance – MT 4 questionnaire				
Fire risks and hazards				
Arrangements for oil fuel, lubricating oil and other flammable oils. Operation of remote means of closing valves on tanks that contain oil fuel, lubricating oil and other flammable oils				
Fire extinguishing and special arrangements in the machinery spaces. Operation of the remote means of control provided for: - opening and closing of the skylights, release of smoke, closure of the funnel and ventilation openings, closure of doors, stopping of ventilation fans, stopping of oil fuel and other pumps that discharge flammable liquids				
REMARKS				
Deck				
Decks, condition				
Watertight doors, condition and operation				
Watertight hatches/coamings, condition and operation				
Bulwarks condition and height				
Freeing port areas – clear of obstructions/blockages				
Embarkation arrangements and launching appliances for each survival craft including relevant tests				
Ease of access to safety equipment				
Encourage owners and crew to wear working lifejackets at all times				
REMARKS				

Checklist of equipment for decked vessels over 10m and under 12m length overall

## ANNEX 1.5

### CODE OF PRACTICE FOR THE SAFETY OF SMALL FISHING VESSELS: CHECK LIST OF REQUIREMENTS

Equipment need not be MCA approved provided it is fit for its intended purpose.

#### DECKED Vessels 10m and above Registered Length to less than 12m Registered Length

"Decked vessel" means a vessel with a continuous watertight weather deck that extends from stem to stern and has positive freeboard throughout, in any condition of loading the vessel.

ITEM	Remarks/compliance	Expiry/Service Date
Lifejackets - 1 per person		
Liferaft		
2 Lifebuoys (1 with 18m buoyant line attached) <u>or</u> 1 Lifebuoy (fitted with 18m buoyant line) +1 Buoyant Rescue Quoit		
3 Parachute flares		
2 Hand-held flares		
1 Smoke Signal (buoyant or handheld)		
Gas Detector		
1 Fire Blanket (light duty) in galley or cooking area (if applicable)		
Smoke Alarms		
1 Fire Pump + Hose <u>or</u> 1 Fire Bucket and lanyard + 1 Multi-purpose Fire Extinguisher (fire rating 5A/34B) + 1 fixed Fire Extinguishing system for the machinery space		
1 Multi-purpose Fire Extinguisher for oil fires (fire rating 13A/113B)		
VHF Radio - fixed (DSC) or hand held		
For distress and urgency communications, it is recommended that VHF DSC is fitted. Coastguard Maritime Rescue Co-ordination Centres maintain a listening watch only on VHF Channel 16 via loudspeaker. The primary means of distress and urgency alerting should be via VHF DSC.		
Bilge Pump		
Bilge Level Alarm		
Navigation Lights & Sound Signals		
Anchor and cable/warp		
Compass		
Waterproof Torch		
Medical Kit		

Note: The checklist represents the minimum safety equipment requirements. Owners should in addition to the above consider carrying additional safety equipment. A radar reflector is recommended for vessels constructed of wood or glass reinforced plastic (GRP) and vessels with no significant steel upper works or masts, an EPIRB is also recommended. Carriage of liferaft with release mechanism is also recommended.

Seago Yachting Ltd liferaft range



# LIFERAFTS

## OFFSHORE

The Offshore liferaft has 2 Butyl rubber tubes which give excellent strength and durability. The canopy is made from a rip-stop nylon making it 100% waterproof unlike rafts that have a polyester canopy which suffer from stress cracks when folded for long periods. The Seago Offshore liferaft has an automatic light, thermo insulated floor, weighted boarding ladder, reflective tape, four 30 Litre water ballast pockets and a rain water collection system, the liferaft is also equipped with an RORC safety pack (see list for details).



VALISE



CONTAINER

**PBO Magazine 2007  
BEST on TEST**

### RORC PACK LIST:-

- 1 X RESCUE QUIT WITH 30M OF LINE
- 1 X PAIR OF OARS
- 2 X SPONGES
- 1 X BAILER
- 1 X WATERPROOF TORCH AND BATTERIES
- 1 X LIFE SAVING SIGNAL CARD
- 3 X RED HAND FLARES
- 1 X FLOATING KNIFE
- 1 X DROGUE (SEA ANCHOR)
- 1 X SET OF REPAIR CLAMPS
- 6 X ANTI SEA SICKNESS TABLETS
- 1 X HAND PUMP



	Tube Dia.	Weight		Packed Dims (mm)	
		Valise	Container	Valise	Container
<b>4 Man</b>	2 x 210mm	23.5Kg	28Kg	L650 x W300 x H320	L720 x W480 x H340
<b>6 Man</b>	2 x 230mm	29Kg	38Kg	L760 x W300 x H460	L790 x W530 x H330
<b>8 Man</b>	2 x 260mm	35Kg	45Kg	L770 x W340 x H480	L800 x W520 x H390

ALL LIFERAFT DIMENSIONS ARE APPROXIMATE AND HAVE.  
LIFERAFTS SHOULD BE STOWED SO THEY CAN BE ACCESSED EASILY.



# LIFERAFTS

## ISO 9650-1

Designed for extended offshore cruising and racing, built and tested to the new comprehensive and technical ISO standard. The New ISO standard for liferafts dictate the type of materials allowed for construction and the performance requirements that have to be met covering inflation, launching, material resistance, buoyancy and interior space.

The Seago ISO 9650-1 liferaft has a large opening with a boarding ramp at the front of the raft with a webbing ladder inside the liferaft to allow a person wearing foul weather clothing and an inflated lifejacket to board the raft alone. The 4 water pockets underneath the raft hold a minimum of 220 Litres which guarantee complete security even in uneven loading conditions. On the underside of the raft there is a self righting stop should the liferaft inflate upside down. The underside of the raft is orange so it can be seen better in dark conditions should it be upside down on inflation. The Seago ISO raft is fitted with SOLAS approved reflective tape an internal light and a SOLAS approved external light.



VALISE



CONTAINER



### ISO SAFETY PACK:-

- 1 X RESCUE QUIT WITH 30M OF LINE
- 1 X PAIR OF OARS
- 2 X SPONGES
- 1 X BAILER
- 1 X WATERPROOF TORCH AND BATTERIES
- 1 X LIFE SAVING SIGNAL CARD
- 3 X RED HAND FLARES
- 1 X FLOATING KNIFE
- 1 X DROGUE (SEA ANCHOR)
- 1 X REPAIR KIT
- 6 X ANTI SEA SICKNESS TABLETS
- 1 X HAND PUMP
- 1 X WHISTLE
- 1 X WET NOTES
- 1 X SIGNAL MIRROR
- 2 X PARACHUTE ROCKETS



	Tube Dia.	Weight		Packed Dims (mm)	
		Valise	Container	Valise	Container
4 Man	2 x 215mm	34Kg	45Kg	L730 x W350 x H470	L790 x W530 x H350
6 Man	2 x 250mm	39Kg	49Kg	L740 x W340 x H480	L790 x W530 x H350
8 Man	2 x 268mm	44Kg	55Kg	L780 x W370 x H430	L830 x W560 x H390

ALL LIFERAFT DIMENSIONS ARE APPROXIMATE.  
LIFERAFTS SHOULD BE STOWED SO THEY CAN BE ACCESSED EASILY.

Information line [redacted] or email [redacted]

Hammar website interactive training tool

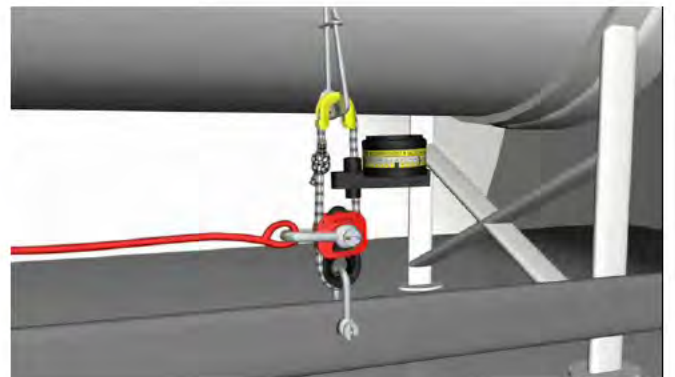
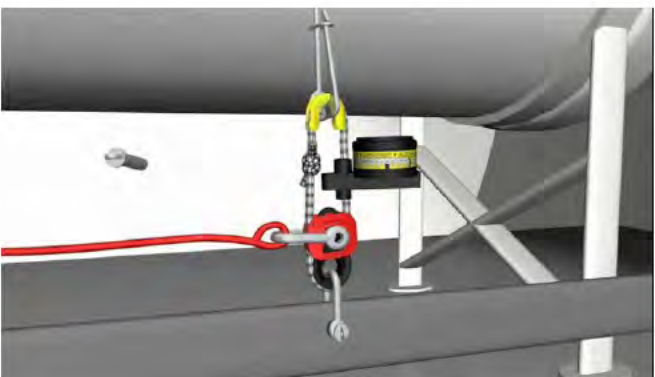
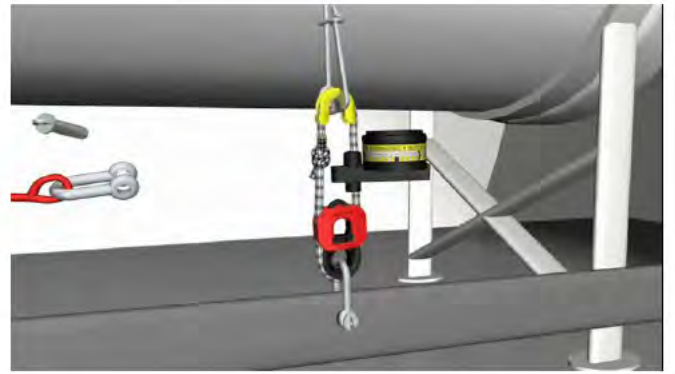
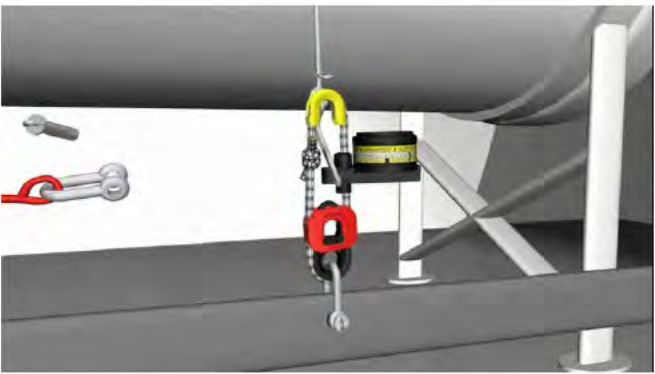
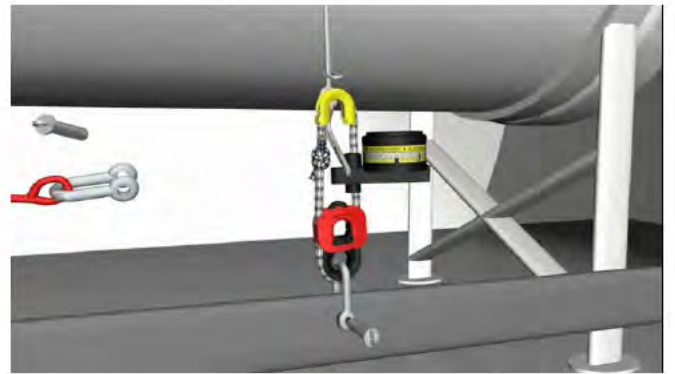
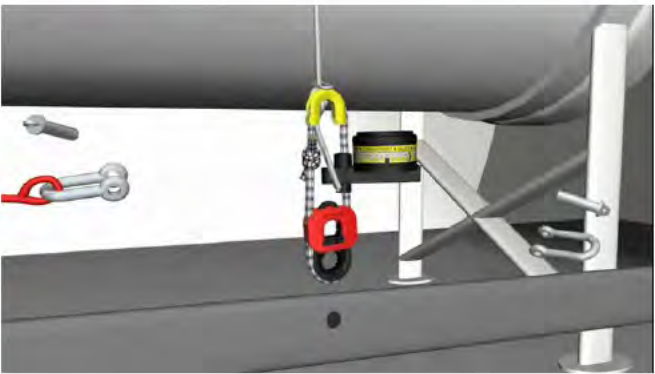
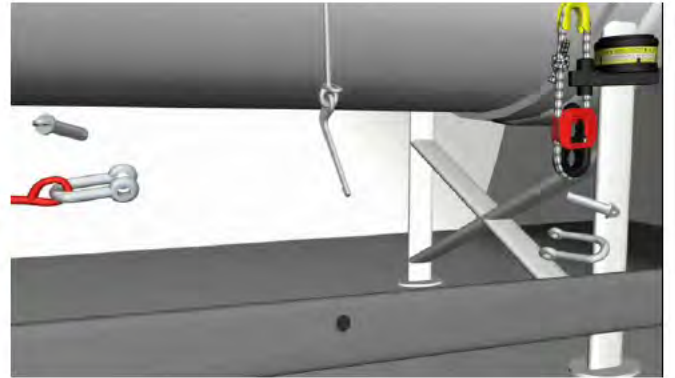
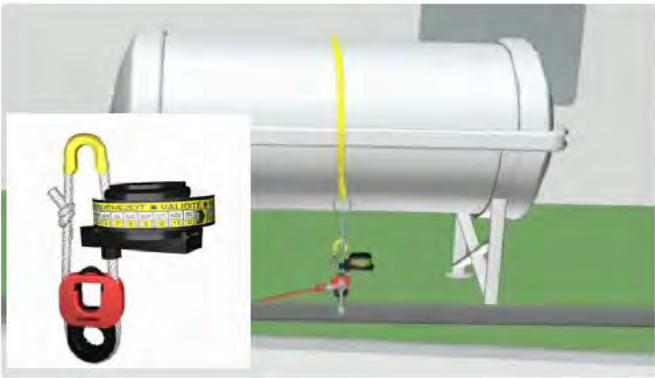

Wooden boat surveyor's report

# Ted Spears Associates

Designers of the World Famous **Bay Class** Range of Yachts

*Marine Surveyors*

*Project Managers*

*Yacht and Small Craft Designers*

---

## DESK-TOP REPORT ON Motor Fishing Vessel "PURBECK ISLE" October 2012



## DESK-TOP REPORT ON Motor Fishing Vessel "Purbeck Isle"

### PREAMBLE

Instructions - were received from the UK Government's Marine Accident investigation Branch (MAIB) to carry out a desk-top survey on the above vessel for the purposes of ascertaining the condition prior to the loss. As follow: -

"I would like to confirm our instruction for you to carryout a desk top survey and provide a report of the material condition of the fishing vessel *Purbeck Isle's* hull and deck prior to her sinking using the photographic evidence provided. To support you in this task, I have also provided some background information regarding the vessel's construction, modifications carried out and repair history.

Points of particular interest include:

Condition assessment of fastenings (need for withdrawal)  
Potential effect of hull sacrificial anodes on hull fastenings  
Affects of increased deck load on racking stresses, and effects of racking stresses on fastenings  
Potential cause and contributory factors of transom failure evident on seabed  
Use of tingles on hull"

### LIMITATIONS

This report is based upon the information as presented. No other exploratory work has been undertaken.

I have not been asked to comment upon safety equipment.

I have not been asked to comment upon the propulsion or any other machinery or equipment.

I do not offer any conclusions regarding the cause of the loss.

Signed.....



 MYDSA (Fellow)  
Marine Surveyor

Ted Spears Associates

Telephone 

Mobile 

E-mail: 

Web: [www.tedspearsassociates.co.uk](http://www.tedspearsassociates.co.uk)



Full Surveyor Member  
YDSA

**HULL CONSTRUCTION OF TIMBER HULLED FISHING VESSELS**

It is not known if the vessel was constructed to comply with any statutory regulations. However it is reasonable to assume given the reputation of the builder that at very least the Sea Fish Industry Rules for the Construction of Wooden Fishing Vessels were applied as a code of practice.

By way of example I have applied the up-to-date version (2006) of these rules to a hypothetical vessel of this size in order to establish the approximate scantlings, and fastening sizes for a vessel of this type.

LOA	11.64
Beam	3.62
Draft	0.88
Scantling Numeral	37
Planking Thickness	30mm
Fastening Length	90mm

This vessel is built with “sistered” frames which are normally through-bolted together.

It is normal practice for 2 fastenings to be fitted though every plank into every frame. These fastenings could be galvanised steel spikes which would be fitted into previously bored pilot holes and driven home. Alternatively copper nails with roves on the inside of the frames are fitted as two such fastenings are visible on the photograph (Fig 1.). The ends of the planks at the stem and the transom might have been secured with wood screws but galvanise iron spikes are quite common too. In all cases the heads should be sunken below the surface and the holes in the planking stopped so as to prevent the penetration of moisture. It is possible that both iron spikes and copper clenched fastenings are utilised together.

The seams between the planks are caulked with either oakum or cotton. The act of inserting the caulking tends to apply tension to the whole shell helping the whole assembly become and remain rigid.

The deck on this vessel is built with a plywood main deck and planks fastened over. The seams would have been caulked in a similar manner. The only difference is that the seams would have been payed with a poured-in pitch-like material.

MAIB observation note:  
 Purbeck Isle was constructed prior to publication of Seafish wooden boat construction standards

Decks provide a considerable degree of rigidity to all vessels. Traditional timber craft are no exception.



Fig. 1

This shows a connection between sistered frames and a bilge stringer with the hull planking also visible. Clenched-over copper nails and roves are visible on the inside of the stringer and one of the frames. The area around the nail in the stringer is showing the typical signs of softening and de-lignification. Also seen here is caulking cotton between two sections of frames. This is not how the vessel was originally constructed and suggests movement between the frame sections and leakage through plank seams near the frames.

#### HULL PLANKING IN WAY OF PROTECTION PAD

I have been made aware of previous problems associated with hull planking under the protection pad where the pots are hauled aboard. This pad comprises timber pads screwed to the hull planking. It is understood that some form of plastic covering had been fitted over this pad.

I have also been made aware that *Purbeck Isle* was taken out of the water in January 2011 to repair a sprung plank positioned behind the pad. Clearly the lower part of the protection pad needed to be removed to expose a problem. It is evident from a photograph taken at the time; at least one short length of hull



plank had previously been fitted in this area. It is understood that it was later identified during an out of water refit (October 2011) that this plank runs from one frame to which it was secured across a second frame and terminated short of a third. It is not known how the aft end of this plank was secured to the next one. From the photographs it can be seen that this has had cotton caulked into the seams and a flexible marine adhesive-like material applied to seal. Upon completion the protecting planks (seen lying on the dock bottom) re fastened to the hull. These protection planks do nothing for the strength or the integrity of the hull. Therefore, the short plank was imparting no longitudinal strength to the hull. A plywood patch was fitted over the short plank and the seams during the October 2011 docking. This plank, was therefore effectively being held in place by the plywood patch only.

#### CONDITION ASSESMENT OF FASTENINGS

Fastenings in timber vessels can suffer from two main classes of corrosion - simple electrochemical corrosion and galvanic corrosion.

Simple Electrochemical Corrosion. Simple electrochemical corrosion is the normal way in which metals combine with oxygen to reach their more stable form as metallic oxides. In sea water, dissolved oxygen and chloride ions (from salt) are the principal instigators. The process involves two different types of reactions which take place at distinct locations on the metal-water interface. An interface of metal and wet wood is the same as an interface of metal and water. At the anodes, the free electrons are absorbed in a reaction that consumes the oxygen which is dissolved in the surrounding water or in the water absorbed by the surrounding wood. In open water, the sites of the anodes and the cathodes may be microscopically small and intermixed - the metal may appear to corrode more or less uniformly. For a fastening buried in wood however, the area exposed to oxygen is often limited. The heads of fastenings tend to support oxygen consuming cathode reactions and are thus protected from wastage, while the deeper-buried shanks are where the anode reaction, and the physical wastage takes place. For this reason, exposed or shallow buried heads are often the least-corroded parts of hull fastenings. This is why hull

fastenings in wooden boats cannot usually be adequately assessed without withdrawing them.

Galvanic Corrosion. Different metals have different levels of chemical stability in an electrolyte, causing them to have different tendencies. These differences in are measurable as different electrical potentials, or voltages. These potentials are tabulated in the "Galvanic Series".

When two metals which have different potentials and which are immersed in the same body of water or wet wood are brought into direct physical contact or connected together with a metallic conductor, electric current flows between them. The less stable metal is now said to be undergoing galvanic corrosion, an accelerated form of electrochemical corrosion, while the more stable metal is now receiving cathodic protection, with the other metal serving as a sacrificial anode. In order for galvanic corrosion to occur, the two different metals (dissimilar metals) must be connected electrically (by contact or by a direct metallic link, and they must be immersed in the same body of liquid or wet wood (an electrolyte.) Two or more metals, electrically connected in a common body of electrolyte are called a galvanic cell. Galvanized steel is an example of an intentional galvanic cell - the zinc acts as a sacrificial anode for the steel in the case of a small penetration of the coating.

A variation on this system is "stray current galvanic corrosion" this is where electric current passes through two dissimilar metals in an electrolyte. This needs a source of electricity which could be a defective submersible bilge pump for example. But a direct electrical connection is needed for this to occur. No evidence exists to suggest that the fastenings were connected electrically to each other or other metal objects on this vessel.

Whatever type of corrosion is present it is commonly observed that wood weakens around corroding metal such as nails. Spikes, screws, bolts, and plates in wooden vessels. Damp wood not only causes metals to corrode because wood (especially Oak) is slightly acid, but when a metal fastener is embedded in wet wood, conditions are created that can accelerate the corrosion of the metal. The corrosion products often result in slow deterioration of the wood surrounding the metal. Corrosion of the fastener combined with deterioration of the wood causes loss of strength of the joint and weakening of the structural integrity of the assembly.

The products of corrosion of the steel fastenings are highly alkaline. This will dissolve the lignin (delignification) from the wood leaving stringy and pulpy fibres around the fastening.

This phenomenon is especially prevalent in Oak and is well known to boat builders and surveyors. If the vessel is well built with proper attention paid to the coating of faying surfaces and general good boat building practice then the progress of this will be slowed.

Once the timber becomes saturated the fastenings can start to corrode. With the fastening becoming corroded, losing metal mass and as a direct consequence losing strength and occupying less of the hole into which it was driven the planking will become less securely attached to the frame. Add to this the loss of strength of the timber around the fastening and the defect is exacerbated.

#### THE NEED FOR WITHDRAWAL OF FASTENINGS

As far as I am able to determine none of the U.K. classification societies have hard and fast rules regarding the requirement for the removal of fastenings for inspection. It is left up to the inspecting surveyor's discretion to select such fastenings. A surveyor will look for tell-tail signs that the fastenings are deteriorating including the hull showing signs of rust running out from the stopping over the fasteners or planks coming adrift internally from the frames.

Unfortunately the only way to determine if the deterioration described above is occurring is to remove some sample fastenings for inspection. This clearly becomes problematic once the shank of the fastening has lost much of its strength. As a consequence many old wooden boats are simply re-fastened as matter of course

Once the vessel either reaches a certain age or the tell-tail signs noted above are observed then the surveyor would, in my opinion, request that a number of plank end fastenings and a small random sample of plank to frame fasteners at least be withdrawn. Many surveyors would take the view that once the vessel is more than (say) 25 years old then every 5 years this testing ought to be undertaken. However it is fair to say that this is often not carried out until a significant refit is undertaken to the vessel where replacement of planking etc would reveal such defects.



In this case it is very likely that no fastenings have ever been withdrawn. Certainly no record exists of the condition of fastenings in any of the summaries of the survey reports I have seen.

#### THE POTENTIAL EFFECT OF HULL SACRIFICIAL ANODES ON HULL FASTENINGS

Sacrificial anodes are fitted to vessels to protect submerged metalwork from electrolytic corrosion. The idea is to electrically connect (bond) the anode to submerged metalwork that is to be protected. It is clearly impossible to electrically bond every fastening to the anodes. Therefore no proper protection of the fastenings is offered.

From my research, anecdotally it is thought by many that it is possible to “over anode” a wooden boat - this is not strictly true. In fact there is a problem with fitting anodes to wooden boats but this is limited to a small area in way of the anode itself. The problem is caused by the water in the timber close to the anode becoming highly alkaline due to the corroding of the anode. The high alkalinity destroys the timber here by delignification. Sacrificial anodes have no effect upon the rest of the vessel’s planking.

#### THE AFFECTS OF INCREASED DECK LOAD ON RACKING STRESSES, AND THE EFFECTS OF RACKING STRESSES ON FASTENINGS

A planked wooden vessel is subject to complex stresses. Hogging and sagging over waves, twisting in a quartering sea and racking stresses caused by gantries and the like applying torsion stresses are examples of this, often all happening at once.

When the plank to frame, and frame section to frame section fastenings are in good condition the connections are fixed in position i.e. no movement between each component occurs.

When the fastenings begin to deteriorate the attachment of the components loosen somewhat allowing very slight movement between them. This can sometimes be seen quite clearly when a wooden boat is lifted out of the water and is badly supported along its keel. The paint across the plank seams will often show small diagonal corrugations. This is because the planks are trying to move relative to each other. When the vessel is at sea the vessel is being

constantly differently supported and if the planks are moving (albeit slightly) it is not difficult to imagine that first the stopping crumbles away and then the caulking in the seams between the plank becomes loosened and come adrift. Clearly this is a progressive and an accelerating deterioration of the shell. Once caulking is "chewed up and spat out" water can get into the vessel possibly catastrophically.

The original tension that was applied to the shell when new by the act of caulking no longer pertains. All of the above applies to the deck.

Adding gantries, fishing gear, large deck houses all contribute to changing the moment of inertia of the vessel. The craft will tend to roll more easily becoming more tender which will add stress to the hull. The mass of individual components e.g. a gantry will add load to the vessel where it is attached. This will attempt to distort the shape of the hull and deck when the vessel is moving at sea. In this case however the photos show that little top-hammer is fitted. The wheelhouse has been raised up adding to the stress a little. A metal casing is seen on the foredeck in some of the later photos which has what looks like a line hauler attached. This has a strut type davit and a fairlead arrangement presumably for lifting the pots. This is all cantilevered to starboard imparting a twisting motion to the fore part of the vessel when this equipment is in use.

The underwater photograph below (fig. 3) shows a tubular framework attached to the top of the transom which it is understood is intended to carry empty whelk pots. This is quite high and when loaded would add to the stresses on the vessel.

It is understood that the deck of the boat was loaded with a full catch of Whelks and several; strings of pots when she sank. According to the MAIB's assessment the load distributed over the entire area of the deck was between 5 to 7 tonnes. The effect of this load is highly significant. Firstly the deck and its support structure has to carry the load and distribute it to the hull. We do not know what condition the beam shelf and associated knees and brackets were in. we do know the bulwark stanchions were in a poor state. If the connections between the structural members was failing in the same way as for the hull fastenings then the whole boat will be racking and flexing to a much greater extent with the load on deck. Secondly the vessel would be much lower in the water. I estimate that the sinkage on a vessel such as this would be in the region of 250 to 300Kg per cm. Therefore in the loaded condition she would be some

200 to 300mm lower in the water. This will increase the hydrostatic head applying more pressure to the hull planking. The inertia of this mass will add to the twisting of the hull structure considerably in a seaway. The concentration of this mass will also add to the hogging and sagging between waves.

#### GAP IN STARBOARD BULWARK

One further item for consideration is the fact that the bulwarks has been cut through amidships on the starboard side. Bulwarks add fore-and-aft strength to the vessel. Cutting this important structural member without adding any compensating structure is, in my opinion, a contributory factor in the failure of the hull especially when allied with the very poor condition of the bulwark stanchions seen below. I am not of the opinion that the steel door in the bulwarks adds much to the longitudinal strength of the vessel as it is only secured with a shoot bolt



Fig 2. This shows a bulwark stanchion as it passes through the margin plan of the deck. Poured-in melted pitch has been recently applied.



## THE POTENTIAL CAUSE AND CONTRIBUTORY FACTORS OF TRANSOM FAILURE EVIDENT ON SEABED

It is not known precisely how the transom was originally fitted into the hull. We know from the SFIA rules that in order to comply at least one frame should have been fitted at the hull to transom connection. Assuming this to be the case then plank fastenings would have been fitted through the planks into the transom planking and also into the transom frame. The transom planks would have been secured to the transom frame. From various photographs it can be seen that the upper **starboard** corner of the transom had a triangular piece cut into it. It is not known why or when this was done **but it is probable that this was to address some damage or defect. This inserted section is mainly above the deck**. It is also not known how this sections of timber is attached to the hull and transom. It can be seen from the photos that the lower part of the transom has metal tingles fitted.

It is reasonable to presume that the fastenings associated with the transom were in the same condition as the rest of the vessel. It is also reasonable to assume that when the planking was racking whilst at sea then the fastenings here would be under considerable stress.



Fig 3 This shows the transom adrift from the hull planking mainly at the lower end. Remains of tingling at the side to transom connection can be seen. The inserted section in the outer edge near the upper part of the transom is visible.

In trying to imagine why the lower part of the transom has come adrift I considered that air pressure during the sinking might have been the cause. This does not seem correct as if the vessel sank very quickly bow first and air was pressed aft this pressure would have been relieved through the steering hatch. A second possibility occurred to me that a significant volume of water had accumulated below and with the vessel pitching a surge of water could have forced the transom off the vessel. Alternatively the transom simply let go in one piece allowing a very rapid inrush. But why did the transom not close under pressure from the outside like a flap? I can see no broken or bent spikes in the photos.

In any event the damage indicates to me that little or no integrity of the fastenings associated with the transom remained and the transom was not properly secured to the vessel.

#### THE USE OF TINGLES ON HULL

Tingles are normally thin metal plates fitted to wooden vessels by means of nails. These plates are normally made out of lead or copper but other thin materials have been used. These plates are secured by small nails inserted around the edges of the plate (some times in the middle if the plate is large or of a complex shape). A sealant of some kind is plastered over the vessel or the tingle immediately before fitting in place.

The purpose is normally a temporary solution to a leak. This can be a loose fastening, a split in a plank or a seam. Tingles are not a permanent solution to an underlying problem and must be seen as an expedient “quick fix” to enable a vessel to get back afloat.





Fig 4 This shows new tingles being fitted to the garboard seam and the seam above. A small square tingle is fitted in the middle of plank No 2 another across the seam immediately above. Above this a larger rectangular tingle is fitted spanning plank No. 4 and the adjacent seams. The fact that all these are in a line across the vessel indicates to me that movement and leakage is occurring here.

Surveyors will often (but not always) require tingles to be removed during an inspection. This will enable the underlying problem to be examined and attended to. In reality it is far too common for tingles to become permanent. From the various photos a number of tingles have been fitted to the hull. It is not reliably known how long these remained in place but from the summary of survey reports. Most of the tingles seen are over quite short length of plank seams addressing leaks in these parts. The tingles could be the indicator of planks coming adrift and moving because the fastenings have failed. The picture above (Fig.4) is worrying with the tingles in a line suggesting the possibility of a failure on one frame.

This vessel was in quite a poor state and required major re-fastening and re-caulking for her to continue in service.

ENDS

MAIB draft safety flyer to the fishing industry

## FLYER TO THE FISHING INDUSTRY

### ***Purbeck Isle*: Foundering resulting in the loss of three lives**

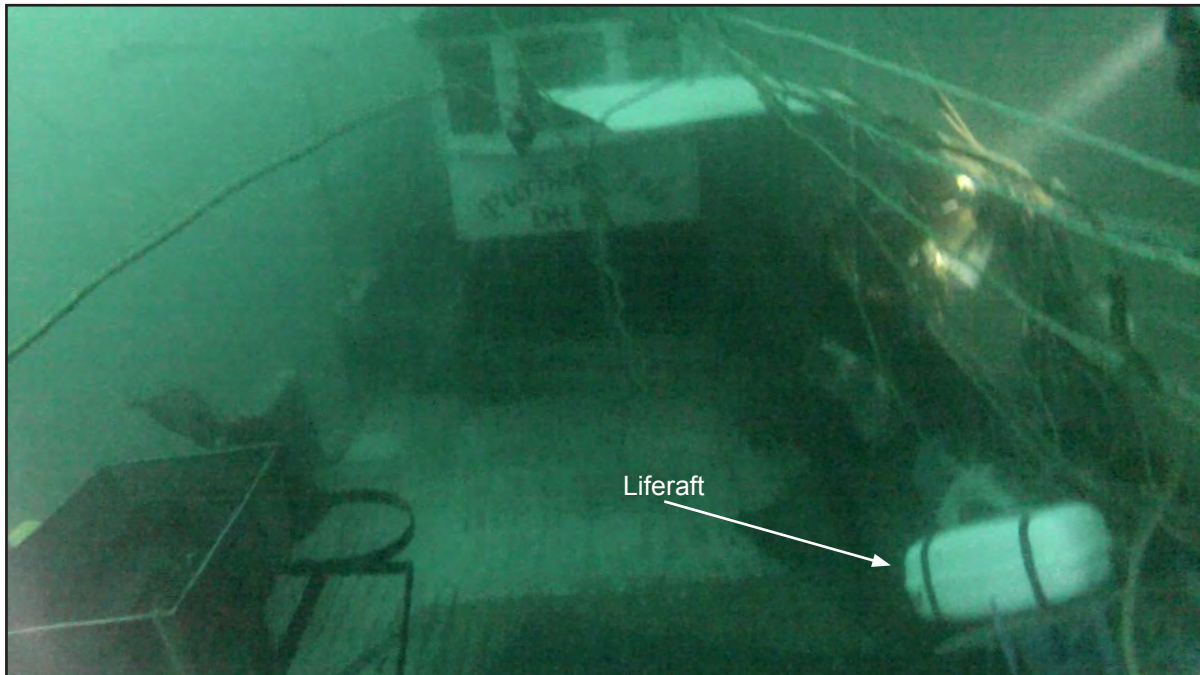

#### **Narrative**

On 17 May 2012, the skipper of the UK registered fishing vessel *Purbeck Isle* and his two young crewmen died because the vessel's liferaft failed to float free and automatically inflate when the 11.6m wooden potting vessel sank suddenly off the coast of Portland, England.

The day before the accident, the fishermen had moved about half of the vessel's whelk pots from the skipper's preferred sheltered winter grounds in Lyme Bay to deeper grounds 9 miles south of Portland Bill. On the day of the accident, the fishermen had left Weymouth harbour at about 0415 with the intention of relocating the remainder of their gear. When they arrived at their winter grounds the crew hauled and stacked 5 or 6 strings of pots onto *Purbeck Isle's* deck and the skipper then headed the vessel south towards the grounds. At about 1000, shortly after the crew had begun to re-shoot their pots 9 miles south of Portland Bill, the heavily loaded wooden vessel suddenly foundered.

*Purbeck Isle* went down so quickly that the fishermen were unable to broadcast a "Mayday", collect their lifejackets from below deck, or manually launch the vessel's four man liferaft prior to entering the water. As the vessel sank, the hydrostatic release unit (HRU) used to secure the liferaft in its cradle on the wheelhouse roof activated as designed, but the raft failed to float free and sank to the seabed 50m below. As *Purbeck Isle* was not fitted with an EPIRB or similar emergency distress signalling device, over 7 hours elapsed before a concerned local fisherman alerted the coastguard to the fact the vessel was overdue. By this time, all three fishermen had most probably already succumbed to the effects of the cold choppy seas.

## Safety Lessons

A liferaft is required to be stowed and secured in such a way that it will float free of a sinking vessel and automatically inflate. Had *Purbeck Isle's* liferaft floated free and inflated as the vessel sank, it is entirely possible that three lives would have been saved.

The investigation found that although the liferaft's HRU activated as designed, *Purbeck Isle's* liferaft failed to float free and automatically inflate because it had not been correctly stowed or secured in its cradle on the wheelhouse roof. Because the liferaft canister did not fit snugly into its cradle, the skipper had applied additional lashings to prevent it from falling off the wheelhouse roof in heavy seas. These additional lashings had been intertwined with the liferaft's main lashing rope and they prevented the raft from floating free.



However, had the liferaft floated free, it would not have automatically inflated because its painter had not been attached to the HRU's weak link. The liferaft had also been stowed upside down in its cradle. This would have allowed water to build up inside its canister, reducing its inherent buoyancy and increasing the likelihood of its inflation mechanism suffering from corrosion and failing.

Liferafts save many lives every year, but they are often found to be rigged incorrectly. In order to prevent similar failures in the future, fishing vessel owners are strongly advised to ensure that:

1. Liferafts are stowed and secured in accordance with the guidance provided in MGN 343 (M+F) ([www.dft.gov.uk/MCA/](http://www.dft.gov.uk/MCA/)).
2. They follow the instructions provided by liferaft and HRU manufacturers.

Note: CM Hammar's website includes free interactive training aids and video clips that show clearly and simply how its HRUs should be rigged and how they are designed to work in an emergency ([www.cmhammar.com](http://www.cmhammar.com)).

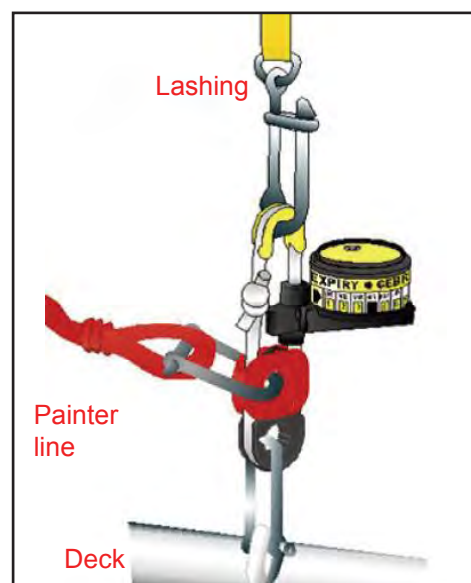

This flyer and the MAIB's investigation report are posted on our website: [www.maib.gov.uk](http://www.maib.gov.uk)

For all enquiries:

Marine Accident Investigation Branch  
Mountbatten House  
Grosvenor Square  
Southampton  
SO15 2JU

Tel: 023 8039 5500

Email: [maib@dft.gsi.gov.uk](mailto:maib@dft.gsi.gov.uk)

May 2013