

**Report of the Investigation**  
**into an engine room fire on**  
**mv *Pride of Le Havre***  
**on 18 March 1999**  
**off the Isle of Wight**

**Extract from**  
**The Merchant Shipping**  
**(Accident Reporting and Investigation)**  
**Regulations 1994**

The fundamental purpose of investigating an accident under these Regulations is to determine its circumstances and the causes with the aim of improving the safety of life at sea and the avoidance of accidents in the future. It is not the purpose to apportion liability, nor, except so far as is necessary to achieve the fundamental purpose, to apportion blame.

# CONTENTS

	<b>Page</b>
GLOSSARY OF ABBREVIATIONS & ACRONYMS	
SYNOPSIS	1
<b>SECTION 1      FACTUAL INFORMATION</b>	<b>2</b>
1.1      Particulars of Vessel and Incident	2
1.2      Background to Voyage	3
1.3      Narrative	3
1.4      Description of Thermal Oil System	7
1.5      Thermal Pump History	8
1.6      Machinery Space Fire Extinguishing Arrangements	9
1.7      Fire Damage and Repairs	9
1.8      Vessel and Coastguard Response	10
<b>SECTION 2      ANALYSIS</b>	<b>11</b>
2.1      Circumstances of the Fire	11
2.2      Crew Response	11
2.3      Other Issues	13
<b>SECTION 3      CONCLUSIONS</b>	<b>15</b>
3.1      Findings	15
3.2      Other Findings	16
3.3      Cause of the Fire	16
3.4      Contributory Cause	16
<b>SECTION 4      RECOMMENDATIONS</b>	<b>17</b>
GLOSSARY OF TERMS	
ANNEX 1      Copy of chart showing drift of <i>Pride of Le Havre</i>	
ANNEX 2      Class certificate showing extent of damage and repairs	
ANNEX 3      Fire fighting equipment positions in machinery spaces	
ANNEX 4      Detail of thermal oil pump	
ANNEX 5      Thermal Oil Product detail	
ANNEX 6      Photographs	

## GLOSSARY OF ABBREVIATIONS AND ACRONYMS

Ro-Ro	-	Roll on/Roll off [designed for the carriage of vehicles]
BST	-	British Summer Time
ECR	-	Engine Control Room
SCBA	-	Self Contained Breathing Apparatus
CO <sub>2</sub>	-	Carbon Dioxide Gas
Hz	-	Hertz or unit of frequency
Ph	-	Phase
IOW	-	Isle of Wight
UTC	-	Universal Co-ordinated Time
HVAC	-	Heating, Ventilating, & Air Conditioning
AFFF	-	Aqueous Film Forming Foam
NUC	-	Not Under Command

## SYNOPSIS

This accident was notified to the Marine Accident Investigation Branch (MAIB) by the Maritime Rescue Sub-Centre Solent at 0430 on Thursday 18 March 1999. The investigation started later the same day and was undertaken by Mr A Rushton.

*Pride of Le Havre* is a 33,336 gross tonnage passenger/ro-ro cargo vessel operating a regular ferry service between Portsmouth and Le Havre. She is registered in Portsmouth, UK and is managed by P&O European Ferries (Portsmouth) Limited. The vessel is fitted with bow and stern doors and is capable of carrying 590 cars and 1600 passengers. Propulsion is by four diesel engines driving through two controllable pitch propellers. Two transverse thrust units are fitted forward.

The vessel had sailed from A&P's King George V dry dock, Southampton just after midnight on Thursday 18 March, for engine trials off the south coast of the Isle of Wight. The intention was that after these trials, *Pride of Le Havre* would berth at Portsmouth, and re-enter service later that day.

Shortly after passing the Nab Tower, the bridge fire alarm activated at 0425, indicating a fire in the machinery spaces. At about the same time, a motorman reported to the engineer watchkeeper that a fire had broken out on the starboard thermal oil pump. While initial attempts were being made to put the fire out using portable extinguishers, the chief engineer was called and the bridge informed of the situation. On confirming that the initial attempt had failed, the chief engineer advised the bridge that he proposed to use the Halon total flooding extinguishing system. The general alarm was sounded and the main engines stopped. The engine room was evacuated and sealed, with Halon being released at 0437. The coastguard and owners were told of the situation with a "Securite" message being broadcast to local shipping. The coastguard activated "SOLFIRE" as a precautionary measure. The crew were mustered, fire fighting procedures and routines carried out, with engine room temperatures being regularly monitored. Brittany ferry *Duc de Normandie* stood by but was later relieved by the Bembridge lifeboat.

An IOW fire brigade team boarded at 0641 with re-entry to machinery space at 0958. Funnel vents were re-opened at 1030 with a fire extinguishing foam blanket laid down in the main machinery space. Ventilation of the engine room started at 1210 with full electrical power available by 1330. Under the direction of the chief engineer, the engine room crew started systematically checking and preparing machinery until, at 1750, No 4 main engine was started followed shortly afterwards by No 1 main engine.

*Pride of Le Havre* sailed under her own power back to Southampton where she re-entered the dry dock berth to undergo examination and repair. She was all fast alongside at 0033 on Friday 19 March 1999.

## SECTION 1      **FACTUAL INFORMATION (all times BST)**

### 1.1      **PARTICULARS OF VESSEL AND INCIDENT**

Name	:	<i>Pride of Le Havre</i>
Official No	:	725334
Port of Registry	:	Portsmouth, UK
Gross Tonnage	:	33,336
Overall Length	:	165.00m
Breadth	:	33.40m
Maximum Draught	:	6.526m
Year of Build	:	1989
Type	:	Passenger/ro-ro cargo
Main Engines	:	SULZER Diesel 8ZAL40S 4 off total 19,600kW
Propulsion	:	Two Controllable Pitch Propellers
Generators	:	4 x 1795kW 660V 60Hz 1 x 500kW 440V 60Hz
Owners	:	Island Shipping Ltd, Bahamas
Managers	:	P&O European Ferries (Portsmouth) Ltd
Classification Society	:	Germanischer Lloyd
Date and Time	:	18 March 1999, 0430 UTC
Place of Incident	:	About 6 miles south of Nab Tower
Injuries	:	None
Damage	:	Fire damage to thermal oil pumps, heat and smoke damage to general area.

## 1.2 BACKGROUND TO VOYAGE

*Pride of Le Havre* is owned by Island Shipping Limited, a Bahamian company, with disponent owners and bareboat charterers P & O European Ferries (Portsmouth) Limited UK, operating as managers since 1993. The management company, together with its sister companies, P & O North Sea Ferries, P & O Irish Sea Ferries and P & O Scottish Ferries, currently manage 21 vessels on UK-Europe ferry routes.

On completion of her annual refit, the vessel left Southampton King George V dry dock at 0140 on Thursday 18 March for Portsmouth. The intention was to carry out engine trials en route for Portsmouth before re-entering service later that day. No 2 main engine had been overhauled during the refit and the trials were to ensure that the overhaul was satisfactory. In addition to a full crew, the vessel carried 27 contractors who were either involved in the trials or completing outstanding refit work.

Before leaving, the chief engineer doubled up the watch and placed the engine room crew on six hour watches. Two third engineers and two motormen were on the midnight to 0600 watch. The main engines were started at about 0130, clutched in, and control transferred to the bridge at about 0200.

## 1.3 NARRATIVE

- 1.3.1 After leaving Southampton at 0210, *Pride of Le Havre* passed down the Solent under pilotage until 0339 when the pilot disembarked. During this period, all four main engines were operating on light load with three generators providing electrical power. Heating for the HVAC, domestic and fuel systems was being supplied by the thermal heating system. Full away was rung at 0408 and the vessel proceeded on a south-south-easterly course to the west of the Nab Tower.

With all machinery apparently operating normally, the chief engineer left the ECR at about 0345 and went to his cabin. The two watchkeeping third engineers, Ramsden and Gardiner, continued to monitor the machinery and carry out routine tasks. While Ramsden remained in the ECR, Gardiner toured the engine room, generator room and purifier space. During this tour, he was pumping the various engine space bilges, one of which was about 1.2m from the thermal oil pumps. Nothing unusual was noticed, and he returned to the ECR at about 0415. Two motormen, O'Brian and Channon, were also in and about the engine spaces, tidying up and carrying out their normal duties.

- 1.3.2 Ramsden, who had remained in the ECR to monitor the machinery, spoke to the chief engineer at about 0410 confirming that all was well. On the return of Gardiner to the ECR, Ramsden left and went aft through the main engine room to the purifier space. He noticed nothing unusual and, on entering the purifier space, closed the watertight door. One of the motormen, O'Brian, was in the

area tidying up. The other motorman, Channon, then approached O'Brian and asked him to come and check something, as he could smell "burning electrics". O'Brian confirmed something was wrong around the thermal oil pumps and went to report to Gardiner in the ECR.

On arriving in the ECR, O'Brian reported that there was a smell of "burning electrics" by the thermal oil pumps. At that moment, the fire alarm began to sound. The fire alarm is recorded in the bridge log book as having sounded at 0425. Almost immediately, the other motorman, Channon, arrived to say that the thermal oil pump was on fire.

- 1.3.3 Gardiner went straight to the main engine room and the thermal pumps, followed by both motormen. By this time flames were coming out of both sides of the pump casing. Both motormen were sent to get fire extinguishers while Gardiner went to the local control panel to change the pumps over. While he was doing this, the motormen discharged dry powder at the flames, putting the fire out. Gardiner, realising that a serious fire risk remained, decided that he should return to the ECR and alert both the chief engineer and the bridge. This he did, calling both the bridge and the chief engineer. The bridge log book records this as being at 0428.

Ramsden, still working in the purifier room, heard the fire alarm sound and went to the watertight door leading back into the engine room. On opening it, he saw flames and smoke around the starboard thermal oil pump, and a motorman using a fire extinguisher. As smoke was beginning to build up in the area, he re-entered the purifier room, shut the door, and tried to telephone the ECR but found the number engaged. He cracked open the door again, saw only smoke so closed the door. After again unsuccessfully trying to contact the ECR, he left the purifier room through the emergency escape and made his way to the ECR via the car deck.

- 1.3.4 The chief engineer arrived in the ECR and asked for an update on the fire and the condition of the thermal oil pumps. As the position seemed confused, he went to see for himself, taking both motormen with him. Carrying a dry powder fire extinguisher, he entered the main engine room through the watertight door. Telling the motormen to stay by the door, he went to investigate and found the fire still alight and bigger than he expected. After discharging the extinguisher at the fire without much effect - most of the powder was blown straight back at him - he shut the watertight door and returned to the ECR with the motormen.

Once there, he told Gardiner to shut down the main engines while he telephoned the bridge. The master was told that there was a major engine room fire, that the fire parties should be mustered, and that the main engines needed to be stopped. This is recorded in the bridge log book as 0430. The general emergency signal was sounded and the propeller pitch brought to zero. Gardiner had, in the meantime, declutched the port main engines and was shutting the main engines down as instructed. The generators were left running.



Ramsden had, by then, entered the ECR and was told by the chief engineer to go with O'Brian and shut the funnel fire flaps. The second engineer, McManus, who had appeared in the ECR in response to a call from Gardiner, was told by the chief engineer that the engine room was to be sealed and Halon released into the space. All staff left the engine room and ECR and made their way to the Halon room on deck 3, just above the ECR. They were joined there by second engineer Daubney. Realising that he had no radio to communicate with the bridge, McManus returned quickly to the ECR and retrieved a number of VHF sets before Halon was released. On his return, both second engineers were sent to operate the quick closing valves for the generators, main engines and ventilation stops, and to check progress on the closing of fire flaps. The chief engineer contacted the bridge at 0435 stating that the area was clear of personnel, a third engineer had been sent to shut the funnel flaps, and he was standing by to release the Halon. At 0437 Halon was released into the main and auxiliary engine rooms.

- 1.3.5 The master had been called at 0428 after the bridge fire alarm panel had activated and the engine room had confirmed the fire. As the situation developed and the main engines were stopped, a "Securité" message was broadcast and NUC lights exhibited. At 0433, Solent Coastguard was contacted on Channel 16 and asked to stand by. At 0439, after Halon had been released into the engine room, Solent Coastguard was advised of the situation. P&O Portsmouth was informed and responded by activating their emergency response plan. Brittany ferry *Duc de Normandie* which was in the area, offered, and was requested, to stand by. Solent Coastguard advised that they had put "SOLFIRE" into action.
- 1.3.6 Third engineer Bolton was off-watch in his cabin when the general alarm sounded. On the way to his emergency station he met third engineer Ramsden who told him what had happened and that he was on the way to shut the funnel fire dampers. In the circumstances Bolton decided to assist Ramsden and between them all dampers and vents were closed. While they were doing this they heard the Halon being released. On completion, the master, who was in the vicinity and had a radio, told the chief engineer that all dampers and vents had been closed.

Both third engineers then left to go to their emergency stations, Bolton to the Fire Drencher Station, and Ramsden to the car deck to join second engineer McManus. On the way down, Bolton took charge of No 2 Fire party because their leader, the second engineer, was down on deck 3 with the chief engineer. The party then went down to the car deck to link up with the chief and second engineers who were by then organising the emergency teams.

On the car deck, fire teams were organised to bring two SCBA sets and a foam branch down from number two fire locker while others were connecting and charging hoses ready for use. Although the electrically driven fire pump was running, fire main pressure was low. An investigation found an overboard

discharge valve on the pump had been left open. Once shut, fire main pressure was restored

The remotely operated fuel shut-off valves were re-checked for satisfactory operation. Two found still partially open were shut using the system hand pump.

- 1.3.7 The chief engineer left the car deck and went to the bridge to update the master, leaving the senior second engineer in charge. On confirming that an SCBA set was then available, he called the second engineer and arranged for an entry to be made to the purifier room to check for hot spots etc. A team of two entered at about 0451, and reported that the area was clear of smoke and that there were no hot spots on the bulkhead. Instructions were given to prepare a fire team with SCBA sets, foam branch and hoses for re-entry at a later stage.

By 0458, all crew and contractors had been mustered and accounted for.

Monitoring of bulkheads and car deck continued while waiting for the evidence that the fire had been contained and that the engine space was cooling down. At 0550, discussions were held with the Isle of Wight fire service over a recommended time for re-entry to engine room. They suggested two hours. It was also arranged that a fire team from the Isle of Wight fire service would be airlifted on board with a thermal camera to advise and assist as necessary. At 0615, *Duc de Normandie* stood down, as Bembridge lifeboat would be arriving to stand by.

- 1.3.8 At 0635, the master briefed the crew in the mess room as to what had happened and what was likely to happen in the following few hours. Shortly after this, at 0641, the first firemen arrived on board by helicopter. The second crew were delayed by bad visibility but eventually boarded at 0830. The firemen were briefed by the master and chief engineer on arrival. The firemen and chief engineer prepared to enter the engine room at 0845.

At 0927, with the fire teams ready for entry, the funnel vents were cracked open to release any pressure in the engine room and to ensure that smoke etc would be vented out of the funnel and not back into the purifier room. The bulkhead between the purifier room and the engine room was checked with the thermal image camera, but no hot spots were found. At 0958, the chief engineer and the fire team cracked open the watertight door between the purifier room and the main engine room. With a fire team in attendance, the door was slowly opened while radio contact was maintained with the second engineer on deck to ensure that the funnel vents were opened progressively so as to allow a through draught of air upwards.

- 1.3.9 On entry to the engine room, the area was found clear of smoke and heat apart from only two hot spots on the thermal oil pipes. Thermal oil was found to be leaking slowly from pressure pipes and gauges by the pumps. The fire team left the engine room, closing the watertight door behind them. They re-entered a few minutes later with hand tools to seal the leaking gauge pipes before once

again withdrawing to the purifier room. By 1016, the funnel vents were fully open.

After discussion, it was decided that a foam blanket should be laid under the thermal oil pumps as a precautionary measure, while fire teams searched the engine room, ECR and auxiliary engine room for any possible casualties. None were found. After the foam blanket had been laid in the engine room, preparations were made to ventilate the auxiliary engine room so that a full examination of the machinery could be carried out. The air compressors required attention first, as control air was necessary to re-start the machinery plant.

- 1.3.10 By 1330, main electrical power had been restored with the generators being started sequentially and other machinery slowly being brought back into service. After discussion with Solent coastguard, the Bembridge lifeboat was released at 1400. At 1608, the first of the Isle of Wight fire teams were lifted off the vessel by helicopter with the second and remaining fire staff departing at 1648. A copy of the vessel's drift from the time the fire broke out until propulsion was regained is in annex 1.

At 1750, No 4 main engine was started, and No 1 three minutes later. They were clutched in shortly afterwards and control transferred to the bridge at 1759. The vessel was underway at 1801 and was all fast alongside at King George dry dock, Southampton, with main engines shut down at 0033 on Friday 19 March.

## **1.4 DESCRIPTION OF THERMAL OIL SYSTEM**

- 1.4.1 The thermal oil system consists of a closed loop heating circuit using either oil fired boilers or main engine exhaust gases for thermal oil heating. The heated thermal oil is circulated by two electrically driven pumps providing a heating medium for a variety of purposes, both domestic and ship services.

The two auxiliary heating boilers are fuel oil fired, with a working pressure of 10 bar and temperature of 185<sup>o</sup>-190<sup>o</sup> C. Each has a capacity of 2035kW and a throughput of 120m<sup>3</sup>/hr. The four exhaust gas boilers, each positioned in the uptake from a main engine, have a capacity of 1046kW and a throughput of 38m<sup>3</sup>/hr.

The two electrically driven thermal oil circulating pumps, each of 75kW and running at 3575 rpm, consist of a single stage centrifugal impeller fitted to a shaft, running in a sleeve bearing at the pump end, and a deep groove ball-bearing at the electric motor drive end. The sleeve bearing is contained in a thermal oil filled bearing bracket, sealed at the drive end, by a mechanical seal. Details of the pump are in annex 4. In addition to the closed system service pipework, a header tank is fitted in the funnel and a double bottom drain tank below the thermal oil circulating pumps on deck 1.

- 1.4.2 The thermal oil used in the system is “SHELL Thermia Oil B” with a flash point of 232<sup>0</sup> C and an autogenous ignition temperature of 375<sup>0</sup> C. It also has a low toxicity rating. The thermal oil product detail is in annex 5.

The closed system is fitted with two pneumatically operated dump valves, one in the funnel underneath the header tank and the other underneath the circulating pumps. Operation of a control valve in the fire control point on No 4 deck, admits compressed air at 5 bar to the dump valves causing them to open, draining the thermal oil down into a double bottom tank. Micro switches, fitted to the dump valves, show the open/shut valve position at the fire control point.

The heated thermal oil is utilised in the following systems:

- Fuel oil heating
- Tank heating
- Trace heating
- Oily water separator
- Swimming pool
- Heating and ventilating system
- Domestic fresh water.

The oil fired boilers and thermal oil pumps are positioned at No 1 deck level (tank top level) between the four main engines. The four exhaust gas boilers are in the exhaust uptakes between decks 7, 8, & 9.

## **1.5 THERMAL PUMP HISTORY**

- 1.5.1 The thermal oil pump records show that there were three previous incidents where failure occurred. The port pump suffered its first failure in May 1998 and a second one in July 1998. The starboard pump suffered a failure in January 1997. On all three occasions, a bearing/seal failure was involved.

One of these failures resulted in a minor fire in the pump area which was extinguished by the crew using a portable extinguisher.

- 1.5.2 The pumps are covered under a planned maintenance schedule which requires a six monthly check of the coupling, mechanical seal, holding down bolts and the application of grease as required. This schedule was last carried out on No 1 pump in March 1999 and No 2 pump in December 1998.

The manufacturer’s recommendations include changing the bearings after 15,000 operating hours or two years, with more frequent changing if operating conditions demand it. The mechanical seal, sleeve bearing, valves and impeller wear rings are subject to replacement on leakage or performance fall-off.

In addition, a five-year survey is carried out concurrently with the six monthly check, at which time the pump is opened up for a full or partial inspection

depending on condition and performance. This survey was last carried out on No 1 pump in March 1999 and No 2 pump in December 1998.

## **1.6 MACHINERY SPACE FIRE EXTINGUISHING ARRANGEMENTS**

- 1.6.1 The Halon system covering the machinery spaces is divided into two zones, machinery space 1 and machinery space 2. Machinery space 1 covers the purifier room while machinery space 2 covers the upper and lower decks of the main engine room, the upper and lower generator room plus workshops, and the engine control room.

The Halon gas bottles vary in size between 47kg and 70.8kg depending upon the area to be covered. The bottles are placed individually around the machinery spaces and are released by compressed CO<sub>2</sub> gas via the control point on deck 3 outside the central access to the engine room.

- 1.6.2 In addition to the Halon, the engine spaces are supplied with 42 x 6kg dry powder portable extinguishers, 4 x 50kg dry powder trolleys, 5 x 6kg CO<sub>2</sub> extinguishers, 7 x 20 litre foam compound packs plus hydrants, hoses, foam applicator, fog lances etc. Two self contained breathing apparatus (SCBA) sets are also available in the engine control room.

A detailed plan of the fire fighting equipment positions in the machinery spaces is in annex 3.

## **1.7 FIRE DAMAGE AND REPAIRS**

- 1.7.1 Following the fire, a survey of the damaged area was carried out by Germanischer Lloyd and the owner's superintendents. Although the area of actual fire damage was very localised, the effects of heat and smoke on adjacent equipment, controls and electric cabling necessitated detailed inspection and system proving. A list of the overhaul/repair work considered necessary is in annex 2.

On completion of the work, a further Class survey was carried out. All items listed were confirmed as having been successfully repaired and/or renewed with the exception of two. These were:

- a) Control air dryer unit to be renewed and surveyed by 30.04.99.
  - b) Buckled deck plating and support beams above thermal oil circulating pumps to be renewed as necessary by 31.03.2000.
- 1.7.2 An examination of the starboard thermal oil pump (No 2) showed heavy contact wear between the thrower and the discharge cover, indicating that the impeller shaft had moved forward, away from the drive motor. The deep groove ball race on the drive end of the shaft had suffered damage with some

of the balls missing and the cage broken up. No obvious damage was seen on the mechanical seal components, but with failure of the ball-bearing and the subsequent movement of the shaft, some misalignment probably occurred.

Following the starboard pump strip down and examination, it together with the port one and a spare, was rebuilt using reconditioned and new parts as required. The pumps were refitted, the system refilled and the plant brought back into operation.

## **1.8 VESSEL AND COASTGUARD RESPONSE**

- 1.8.1 The response of the officers and crew to this emergency was prompt and correct. Directly the extent of the fire and its effect on the safety of the vessel had been confirmed, a “Securité” message was broadcast, NUC lights exhibited and Solent coastguard contacted. The crew and contractors were mustered and the whereabouts of all personnel established. Owners and coastguards were kept informed as the situation developed.

The response by the chief engineer and his staff to the fire was correct and followed good practice. Discussions between *Pride of Le Havre* and the coastguards led to a call to the Isle of Wight fire service for additional advice and possible support. The vessel’s fire teams responded as required with senior officers taking charge, as and when the circumstances demanded. Following discussions between the IOW fire team and ship’s senior staff, the subsequent entry and checking of the engine room and adjacent machinery spaces was carried out with a combined team of professional fire fighters and engine room staff.

On confirmation that the fire was out and that the area was safe, the engineering staff, under the direction of the chief engineer, systematically checked through the main and auxiliary machinery. Their efforts resulted in main power being restored in the early afternoon with more and more machinery becoming available, until the first of the main engines was started at 1750. Thereafter the vessel regained mobility and proceeded in towards Southampton and berthed alongside.

- 1.8.2 The situation was monitored continuously by both the master and the management team ashore. The Head Office, once aware of the incident, had made their emergency response team available to assist as required. Similarly, the Solent coastguard had activated “SOLFIRE”, initially at “A” level, as the vessel was in no immediate danger and the crew were handling the emergency successfully. It was decided subsequently to upgrade the emergency to “B” level as the vessel had no reserves of Halon available and re-entry to the machinery space was the preferred course of action. The Isle of Wight fire team boarded to assist not only in re-entry to the machinery space, but also to be in a position to advise on further fire fighting requirements if re-entry led to additional complications.

## **SECTION 2      ANALYSIS**

### **2.1      CIRCUMSTANCES OF THE FIRE**

- 2.1.1 Probable cause of the fire is believed to be failure of the mechanical seal on the starboard thermal oil pump allowing thermal oil at a temperature of about 185° C to leak aft into the bearing housing and out towards the ball-bearing assembly. The collapsed ball-bearing race then allowed thermal oil at a pressure of about 10 bar to leak out aft towards the electrical drive motor. The pressurised oil impacted with the front end of the motor and rebounded back towards the pump casing. The cooling air from the electric motor, which is designed to flow through the electric motor towards the pump casing, assisted in spraying the oil forward.

The likely sequence of events was that the collapse of the ball-bearing initiated the mechanical seal failure. Damage to the face of the thrower supports this scenario, suggesting that the ball race broke up, the shaft moved forward, leading to mis-alignment of the mechanical seal and loss of thermal fluid.

- 2.1.2 Although the temperature of the thermal oil was below its flash point, it is likely to evaporate into “oil mist” when in contact with the hot pump casing. Furthermore, with the debris from the collapsed bearing still present in the bearing housing and the electric motor continuing to drive the shaft at 3575rpm, it is likely that local hot spots would develop as the shaft rubbed the debris between itself and the bearing housing.

These hot spots, apart from raising the temperature of an already hot oil, would probably be sufficient to create the circumstances for ignition and the formation of a flash fire. The close proximity of the electric motor might also have provided a source of ignition.

The use of portable dry powder extinguishers put the fire out, but could not cool the area sufficiently to prevent re-ignition.

### **2.2      CREW RESPONSE**

- 2.2.1 The crew response in general was good. Directly the fire alarm system identified a fire in the engine room, the master was called to the bridge while the chief engineer went to the engine control room. The master advised all the necessary agencies and authorities and kept both shore and shipboard personnel advised of the situation. At no time did there appear to be any loss of composure with all non-involved crew and contractors following the safety advice. Liaison between bridge and engine room was good with all senior officers assisting as required.

The chief engineer, on entering the engine room, went immediately to the reported area of the fire to assess for himself its severity and extent. In order

to minimise damage to the machinery and for the general safety of the vessel, he made the correct decision to use the Halon system. Thereafter, the officers and crew followed the agreed routines and procedures and safely extinguished the fire. The re-entry followed a practised procedure and was carried out with good co-operation between the IOW fire team and the engineering staff.

The IOW fire brigade said that they were impressed with the actions of the ship's crew in dealing with the emergency, and the preparation work they had undertaken for re-entry to the machinery spaces. Their approach had been very professional. The subsequent sequential powering up of the vessel showed that the chief engineer and his senior officers were fully aware of the potential dangers to the vessel and her crew, and had followed a sensible and safe procedure.

- 2.2.2 At the onset of the emergency, although the situation was correctly reported, there appears to have been slight confusion as to the actual situation regarding the state of the thermal oil pumps and the system valves. This was despite the action by both the third engineer and the two crewmen in fighting and containing the fire during the initial stages of the emergency. It may be that, as attention had been focused on fighting the fire and followed by the realisation that the situation had the potential to deteriorate rapidly, immediate recall of the detail under conditions of stress was not possible. This temporary memory lapse did not affect the decision to use Halon, or the time of its release, but under different circumstances, a failure to pass on accurate detail, as soon as possible, could be a crucial factor.

During the early stages of the emergency, an engineer was confronted with the dilemma of either assisting a crew member who was fighting the fire alone, or reporting the fire to the ECR.

The fire alarm had activated, therefore the fire alarm panel on the bridge and in the ECR showed where the fire had occurred. Nevertheless, more detailed information on the fire would have enabled a quick decision to be made as to what fire fighting capability needed to be used.

To provide back-up support to the crew member already using an extinguisher would follow good practice in ensuring that no one person should be left alone to fight fires, and enable the engineer, as a senior crew member, to take charge and assess the seriousness of the emergency. It could however, result in both men being overcome and fire teams being unaware where the two men were in the machinery space. This, in turn, could lead to a further dilemma for the ship's fire teams.

The engineer chose to concentrate on attempting to call the ECR using the telephone, albeit without success - the line being engaged. This choice did not affect the subsequent actions of the chief engineer as he had already been briefed by the other watchkeeping engineer.



The dilemma faced by the engineer is not one that is usually debated during fire fighting courses or seminars but it is one that could be usefully discussed at shipboard safety meetings. Each situation needs to be considered on its merits but useful lessons on how individuals react to risk perception and decision making, as well as the possible overall safety considerations, can be derived from these discussions.

In any emergency, and in particular machinery space fires, teamwork has an essential role in successfully coping with the dangers and difficulties encountered. Practical training exercises should instil the required knowledge and procedures, but it is vital that individuals appreciate the need to consider the overall situation in addition to that immediately facing them.

## 2.3 OTHER ISSUES

- 2.3.1 In the Shell Product Safety Data Sheet, it is recommended that for small fires, foam, dry powder, AFFF, CO<sub>2</sub>, sand etc should be used, whereas for larger fires, foam or water fog should be used. The use of foam extinguishers to provide fire cover for the thermal oil pumps was discussed with the fire brigade and the point made that, although dry powder has a good “flame knock down” quality, it has virtually no cooling effect. In a situation where hot oil is likely to be leaking out, dry powder has to be considered as very much a first aid attempt with the strong possibility that the fire may re-ignite. Its use within a confined space can also cause difficulties as the powder can create a choking atmosphere.

The use of foam, as recommended by the thermal oil manufacturers, would not only provide a seal preventing the hot oil vapours mixing with the atmosphere, but also give better protection against re-ignition. Although a foam applicator, plus compound, is available in each of the three machinery spaces on *Pride of Le Havre*, no portable foam extinguishers are situated there.

Given the previous experience of small fires and/or previous leaks of hot thermal oil, the provision of foam extinguishers in that area specifically for use on the thermal oil pumps, would increase the likelihood of containing a fire and reduce the risk of the fire escalating. Most dry powders contain a stearate which can cause the breakdown of a foam blanket, but product growth in the high density/high volume foam market should allow an acceptable mix of fire extinguisher products to be installed.

The subsequent decision by the chief engineer and the IOW fire team to lay a foam blanket in the area after the fire had been extinguished supports this concept.

- 2.3.2 Although the fire was successfully contained and extinguished, a number of small operational concerns were identified:

- a) The auxiliary engine room fan fire dampers were shut but did not prevent a significant amount of air movement. This was successfully dealt with by fitting plastic sheeting over the fan inlet.
- b) After the machinery spaces had been shut down, and the vessel was operating on emergency power, it was found that the fire main pressure was low. This was subsequently traced to an overboard discharge valve which had been opened to allow a cooling water flow while the fire pump was running in port.
- c) Two of the remote emergency fuel stops did not operate properly and had to be hand pumped down.
- d) During the exit from the machinery spaces and prior to release of the Halon, all the UHF radios were inadvertently left in the engine control room. Fortunately, they were retrieved before the Halon was released, but the third engineer had already left to close the fire dampers and therefore remained out of touch. Communications were eventually re-established by utilising the radios carried by the deck staff.
- e) There exists some doubt as to whether the Halon was released into the machinery spaces before the auxiliary machinery had either been tripped or had stopped. Given the run down time after fuel has been shut off, and the air flow through diesel turbo-chargers during that period, there is a risk that the recommended density of the fire extinguishing gas in a space could be reduced if it is introduced before auxiliary machinery has stopped completely. That reduction in density might be significant in containing and extinguishing a serious fire.

Many of these concerns were addressed at the time they were identified, but it does illustrate that even among a well managed and organised ship's crew, lapses do occur.

## SECTION 3      CONCLUSIONS

These conclusions identify the cause and factors contributing to the accident and should not be taken as apportioning either blame or liability.

### 3.1      FINDINGS

- 3.1.1    Immediately prior to the outbreak of fire, all four main engines were on light load and were operating normally.  
(Ref: 1.3.1)
- 3.1.2    At 0415, third engineer Ramsden passed close to the thermal pumps and noticed nothing unusual.  
(Ref: 1.3.2)
- 3.1.3    The fire at the thermal oil pump was put out initially using a dry powder extinguisher at about 0428.  
(Ref: 1.3.3 & 2.1.2)
- 3.1.4    When the thermal oil re-ignited, the dry powder extinguishing medium proved to be ineffective because of the fierceness of the fire.  
(Ref: 1.3.4)
- 3.1.5    Before Halon was released, all crew were evacuated from the machinery spaces, the main engines were stopped, the funnel fire flaps were shut, and the emergency quick closing stops and valves were operated.  
(Ref: 1.3.4)
- 3.1.6    On being told of the situation, P&O Portsmouth put its emergency response plan into place, while the coastguard activated "SOLFIRE, initially Class A but later Class B  
(Ref: 1.3.5 & 1.7.2)
- 3.1.7    The Isle of Wight fire brigade boarded the vessel at 0641, with a thermal image camera, to advise and assist the crew on possible further fire fighting actions on re-entering the machinery spaces.  
(Ref: 1.3.7, 1.3.8 & 1.3.9)
- 3.1.8    The thermal oil pumps are maintained under a planned maintenance schedule based on 6 monthly and 5 yearly inspections. No 2 pump (starboard) was last inspected in December 1998.  
(Ref: 1.5)
- 3.1.9    An examination of No 2 pump (starboard) showed heavy contact wear between thrower and discharge cover, together with damage to the deep groove ball race on the drive end of the shaft.  
(Ref: 1.7.2)

3.1.10 A number of operational concerns were identified during the investigation:

- a) The auxiliary engine room fan fire dampers were not airtight.
- b) A overboard valve on the fire pump had been left open.
- c) Two emergency fuel stops did not shut properly.
- d) The VHF radio sets were not picked up by the engineers before they left the ECR.
- e) It is possible that Halon was released into the machinery spaces before the generators had stopped.  
(Ref: 2.3.2)

### **3.2 OTHER FINDINGS**

The use of foam, as recommended by the thermal oil manufacturers, would not only have provided a seal to prevent the hot oil vapours mixing with the atmosphere, but would also have given better protection against re-ignition.  
(Ref: 2.3.1.)

### **3.3 CAUSE OF THE FIRE**

While it has not been possible to identify positively the ignition source of a leakage of hot thermal oil through thermal oil pump aft bearing, debris from the collapsed deep groove ball-bearing might have provided local “hot spots” which could have raised the temperature of the already hot oil, and led to ignition of the resultant thermal oil vapour.

### **3.4 CONTRIBUTORY CAUSE**

The collapse of the aft deep groove ball-bearing race allowed mis-alignment to develop in the faces of the mechanical seal of the thermal oil pump and resulted in a leakage of hot thermal oil out of the bearing bracket, into the bearing housing, and then out along the impeller shaft.

## SECTION 4      RECOMMENDATIONS

**P&O European Ferries (Portsmouth) Ltd** is recommended to:

Investigate the possibility of providing suitable foam extinguishers adjacent to the thermal oil pumps as an addition to the existing foam applicator and compound packs provided in the machinery spaces on *Pride of Le Havre* and other vessels.

## GLOSSARY OF TERMS

Autogenous Ignition Temperature	-	The temperature at which ignition will occur without any external heat source being applied.
Fire Drencher Station	-	Control station for water drenching pump.
Flash Point	-	Temperature at which an ignitable vapour is produced.
Halon	-	Fire Extinguishing Gas.
Securité Message	-	Warning Signal.
“SOLFIRE”	-	Solent and Southampton Water Marine Emergency Plan.
“SOLFIRE Class A”	-	A non-routine marine incident that can be dealt with by the Initiating Authority using resources readily available and with little or no impact on land based authorities.
“SOLFIRE Class B”	-	An incident that can be dealt with by the resources readily available where the initiating authorities need some assistance from one or more land based emergency service. No significant impact is anticipated on other land based authorities but they should consider themselves alerted.
Thermal Oil	-	An industrial heat transfer fluid.

- 1. Copy of Chart showing drift of *Pride of Le Havre***

***Pride of Le Havre***  
**18 March 1999**

**2. Class certificate showing extent of damage & repairs**





# Germanischer Lloyd

CLASSIFICATION  
SURVEY REPORT  
BESICHTIGUNGS-BERICHT

HULL	S	
MACH	M	48
REFR	K	

0053 London

1000076

100

INSPECTION OFFICE / INSPECTION

VOUCHER NO.

FORM

REPORT-NO.

PRIDE OF LE HAVRE 32335

GL-REGISTER-NO.

SHIP'S NAME / SCHIFFSNAME

FROM / ON VON / AM 23.03.99 UNTIL BIS 24.03.99 SOUTHAMPTON

DATE OF SURVEY / BESICHTIGUNGSDATUM PLACE OF SURVEY / BESICHTIGUNGSSORT

MSTJ8 8515 19600 9601 + MC E2 AUT-Z

CALL SIGN / US GRW KW (= 0.7355 X PS) KVA REFR.CAP. / M3 KÜHLR.

01.09.94 DAMAGE AND REPAIR SURVEY CHARACTER OF CLASS / KL.-ZEICHEN

CLASS FROM KL.-LAUF VON EXTENDED UNTIL VERLÄNGERT BIS KIND OF SURVEY / BESICHTIGUNGSART

DRY DOCK IM DOCK  SLIPWAY AUF SLIP  AFLOAT AUF WASSER

At request of the owner the following survey(s) was (were) carried out.

Survey of items as reported in survey report M47 following an engine room fire.

Recommendation M47 all dealt with and tested satisfactory. Recommendation now considered deleted.

Recommendation M48 now given

M48-1 - Control air dryer unit to be renewed and surveyed by 30.04.99

M48-2 - Buckled deck plating and support beams above thermal oil circ pumps to be renewed as necessary by 31.03.2000

CLASS CONFIRMED UNTIL 30.04.1999 (SEE RECOMMENDATIONS M46 & M48)

- Ship
- HVT
- HVK
- Insp.
- Owner

B

C

S

M

E

SCHAKA

AUFL

REG

Confirmation of class, if endorsed, is confined to surveys conducted and documented by this report under the provisions of the "Rules for Classification and Surveys".

CERTIFICATE NO. 032335 APPENDED SHEET NO. 04  
ZERTIFIKAT NR. BEIBLATT NR.

ENTRY IN CERTIFICATE:

DAMAGE & REPAIR SURVEY FOLLOWING ENGINE ROOM FIRE. RECOMMENDATION M47 DEALT WITH. SEE RECOMMENDATION M48 NOW GIVEN.  
CLASS CONFIRMED UNTIL 30.04.1999 (SEE M46 & M48)

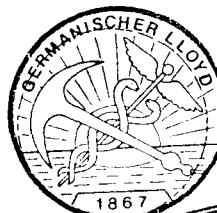

357

HV-EINGANG

SEE REPORT NO. SIEHE BERICHT NR.	M48	PLACE ORT	SOUTHAMPTON	DATE DATUM	24.03.99	( T.R.NATION )
LAST REPORT NO. LETZTER BERICHT NR.	M47	PLACE ORT	SOUTHAMPTON	DATE DATUM	19.03.99	

The latest edition of the "Rules for Classification and Construction, I - Ship Technology, Part 0 - Classification and Surveys" is applicable. Es gelten die "Klassifikations- und Bauvorschriften, I - Schiffstechnik, Teil 0 - Klassifikation und Besichtigungen" in ihrer jeweils neuesten Fassung.



# Germanischer Lloyd

CLASSIFICATION  
SURVEY REPORT  
BESICHTIGUNGS-BERICHT

HULL	S	
MACH	M	47
REFR	K	

0053 London  
INSPECTION OFFICE / INSPECTION

1000075  
VOUCHER NO.

100  
FORM

REPORT-NO.  
**32335**  
GL-REGISTER-NO.

**PRIDE OF LE HAVRE**

SHIP'S NAME / SCHIFFSNAME

FROM / ON VON / AM **19.03.99** UNTIL BIS **SOUTHAMPTON**  
DATE OF SURVEY / BESICHTIGUNGS DATUM PLACE OF SURVEY / BESICHTIGUNG SORT

**MSTJ8** **8515** **19,600.00** **9,601.00** **+ MC E2 AUT-Z**  
CALL SIGN / US GRW KW (= 0.7355 X PS) KVA REFR. CAP. / M3 KÜHLR.

**01.09.94** **DAMAGE SURVEY FOLLOWING ENGINE ROOM FIRE** **CHARACTER OF CLASS / KL.-ZEICHEN**  
CLASS FROM KL.-LAUF VON EXTENDED UNTIL VERLÄNGERT BIS **FIRE**  DRY DOCK IM DOCK  SLIPWAY AUF SLIP  AFLOAT AUF WASSER  
KIND OF SURVEY / BESICHTIGUNGSART

At request of the owner the following survey(s) was (were) carried out.

Damage survey following an engine room fire.

Cause of fire was possibly due to a failed seal or bearing on the stbd thermal oil circulating pump. Fire extinguished by release of the Halon system.

**Recommendation M47 now given**

The following items are to be repaired/overhauled or renewed as necessary. Additional items may also require attention.

- Both thermal oil pumps including pressure gauges/stats etc
- Freshwater pump motors to open and clean (x8)
- Stand-by lub oil pump motors to open and clean (x4)
- Main sea water pump motors to open and clean (x2)
- Main fire pump motor to open and clean (x1)
- Main air start compressor motors to open and clean (x2)
- Both air start and control air compressor to open for inspection
- Air reducers to overhaul (x5)
- Control air receiver to internally inspect
- Control air dryer to renew
- Port main engines fresh water cooling control valves to prove operation
- Thermal oil dump valve and air reducer to strip, overhaul and test
- Thermal oil analysis to be taken
- Aft port thermal oil waste gas heater leakage pot to prove
- Aft oil fired thermal oil fire heater temperature probes to renew
- Both oil fire thermal oil heaters operation test including safety trips
- Fire detection in engine room to repair and prove
- Port main engine clutch operation to prove
- Port inner main engine turning gear starter box to renew
- All heat damaged cables circuits to identify, cables to renew and systems checked or tested as necessary
- Various areas of lagging to be stripped out and renewed

- Ship
  - HVT
  - HVK
  - Insp.
  - Owner
- B
- C
- S
- M
- E
- SCHAKA
- AUFL.
- REG.

Confirmation of class, if endorsed, is confined to surveys conducted and documented by this report under the provisions of the "Rules for Classification and Surveys".

CERTIFICATE NO. **032335** APPENDED SHEET NO. **04**  
ZERTIFIKAT NR. BEIBLATT NR.

ENTRY IN CERTIFICATE :  
**DAMAGE SURVEY FOLLOWING ENGINE ROOM FIRE. SEE RECOMMENDATION M47.**  
**CLASS TO BE CONFIRMED BEFORE DEPARTURE THIS BERTH**

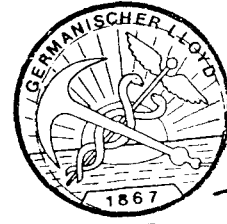

HV-EINGANG

*[Handwritten signature]*

SEE REPORT NO. SIEHE BERICHT NR. <b>M47</b>	PLACE ORT <b>SOUTHAMPTON</b>	DATE DATUM <b>19.03.99</b>	<b>( T. R. NATION )</b>
LAST REPORT NO. LETZTER BERICHT NR. <b>M46</b>	PLACE ORT <b>SOUTHAMPTON</b>	DATE DATUM <b>17.03.99</b>	

SURVEYOR TO GERMANISCHER LLOYD



# Germanischer Lloyd

CLASSIFICATION  
SURVEY REPORT  
BESICHTIGUNGS-BERICHT

0053 London  
INSPECTION OFFICE / INSPECTION

1000075  
VOUCHER NO.

100  
FORM

HULL	S	
MACH	M	47
REFR	K	

REPORT-NO.

**PRIDE OF LE HAVRE**  
SHIP'S NAME / SCHIFFSNAME

**32335**  
GL-REGISTER-NO.

- 22 Halon bottles to be pressure tested and recharged and firing heads checked. System to be re-instated
- 23 Deck structure above thermal oil pumps to be cleaned for inspection in way of buckling

All above items to be re-surveyed on completion

**CLASS TO BE CONFIRMED BEFORE DEPARTURE THIS BERTH**

Confirmation of class, if endorsed, is confined to surveys conducted and documented by this report under the provisions of the "Rules for Classification and Surveys".

CERTIFICATE NO. 032335 APPENDED SHEET NO. 04  
ZERTIFIKAT NR. BEIBLATT NR.

HV-EINGANG

ENTRY IN CERTIFICATE :

DAMAGE SURVEY FOLLOWING ENGINE ROOM FIRE. SEE RECOMMENDATION M47.

**CLASS TO BE CONFIRMED BEFORE DEPARTURE THIS BERTH**

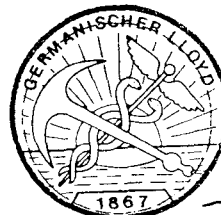

357

SEE REPORT NO. SIEHE BERICHT NR.	<b>M47</b>	PLACE ORT	<b>SOUTHAMPTON</b>	DATE DATUM	<b>19.03.99</b>	<b>( T. R. NATION )</b>
LAST REPORT NO. LETZTER BERICHT NR.	<b>M46</b>	PLACE ORT	<b>SOUTHAMPTON</b>	DATE DATUM	<b>17.03.99</b>	

SURVEYOR TO GERMANISCHER LLOYD

**3. Fire fighting equipment positions in Machinery Spaces.**

# Pride Of Le Havre

## Machinery Space Halon Cylinder Check List

Item W1.12

Pos No	Size	Location	Area covered	Remarks
1	62.3kg	1 Dk Fwd Tk 36 Purif Rm	Machinery Space 2	
2	62.3kg	1 Dk Fwd Tk 35 Purif Rm	Machinery Space 2	
3	62.3kg	1 Dk Stbd Fwd Purif Rm	Machinery Space 2	
4	62.3kg	1 Dk Port by Tk 28 Purif Rm	Machinery Space 2	
5	62.3kg	1 Dk Port Fwd Purif Rm	Machinery Space 2	
6	70.8kg	1 Dk port Aft ME Rm	Machinery Space 1	
7	70.8kg	1 Dk Port Aft ME Rm	Machinery Space 1	
8	70.8kg	1Dk Stbd Aft ME Rm	Machinery Space 1	
9	70.8kg	1 Dk Stbd Aft ME Rm	Machinery Space 1	
10	70.8kg	1 Dk Port Fwd Outbd ME Rm	Machinery Space 1	
11	70.8kg	1 Dk Port Fwd Inner ME Rm	Machinery Space 1	
12	70.8kg	1 Dk ME Rm Midships Fwd	Machinery Space 1	
13	70.8kg	1 Dk Stbd fwd Outbd ME RM	Machinery Space 1	
14	69.6kg	1 Dk Port Aft Alt Rm	Machinery Space 1	
15	69.6kg	1 Dk Stbd Aft Alt Rm	Machinery Space 1	
116	69.6kg	1 Dk Midships Fwd Alt Rm	Machinery Space 1	
17	70.8kg	2 Dk Midships Aft ME Rm	Machinery Space 1	

Date \_\_\_\_\_

Signature \_\_\_\_\_

**Pride Of Le Havre**

**Machinery Space Halon  
Cylinder Check List**

Item W2.12

Pos No	Size	Location	Area covered	Remarks
18	70.8kg	2 Dk Midships Aft ME Rm	Machinery Space 1	
19	70.8kg	2 Dk Port Fwd Outbd ME rM	Machinery Space 1	
20	70.8kg	2 Dk Port Fwd Outbd ME Rm	Machinery Space 1	
21	70.8kg	2 Dk Port Fwd Inner ME Rm	Machinery Space 1	
22	70.8kg	2 Dk Port Fwd Inner ME Rm	Machinery Space 1	
23	70.8kg	2 Dk Stbd Fwd Inner ME Rm	Machinery Space 1	
24	70.8kg	2 Dk Stbd Fwd Inner ME Rm	Machinery Space 1	
25	70.8kg	2 Dk Stbd Fwd Outbd ME Rm	Machinery Space 1	
26	69.6kg	2 Dk ME Store Aft Inner	Machinery Space 1	
27	73kg	2 Dk ME Store Fwd Inner	Machinery Space 1	
28	69.6kg	2 Dk Alt Rm Port Fwd	Machinery Space 1	
29	69.6kg	2 Dk Workshop Sbd Aft Inner	Machinery Space 1	
30	51.1kg	2 Dk Workshop Sbd Mid Inner	Machinery Space 1	
31	51.1kg	2 Dk Workshop Sbd Fwd Inner	Machinery Space 1	
32	69.6kg	2 Dk Alt Rm Port Fwd Inner	Machinery Space 1	
33	47kg	2 Dk Port side Control Rm	Machinery Space 1	
34	47kg	2 Dk Stbd Side Control Rm	Machinery Space 1	

Date \_\_\_\_\_

Signature \_\_\_\_\_

TITLE: SAFETY ITEMS LOCATION.

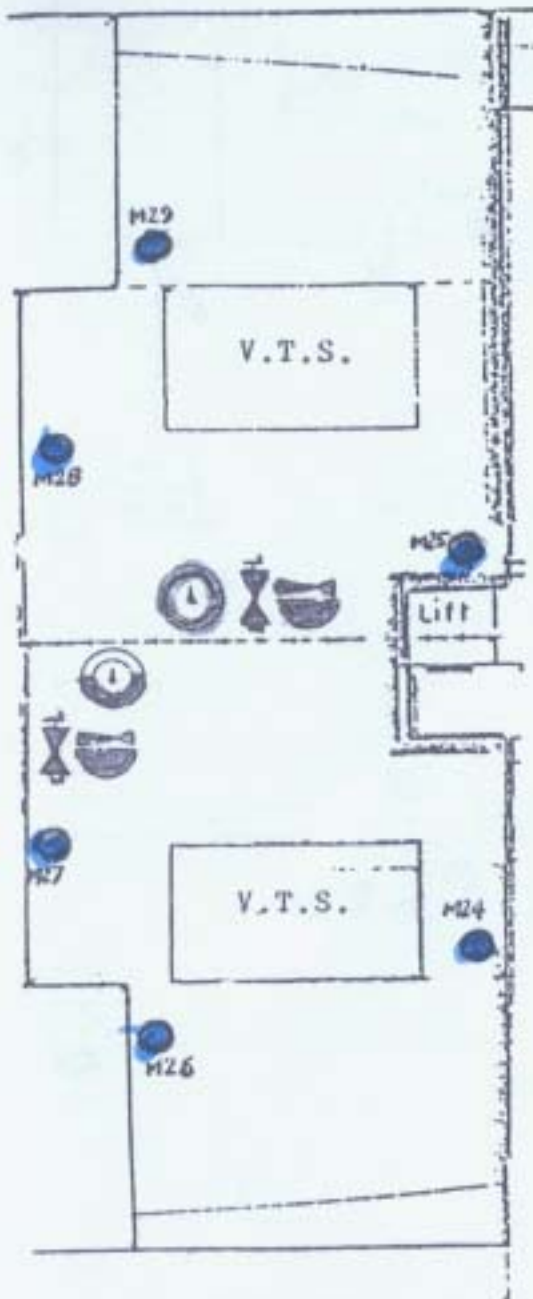

PUMPROOM.

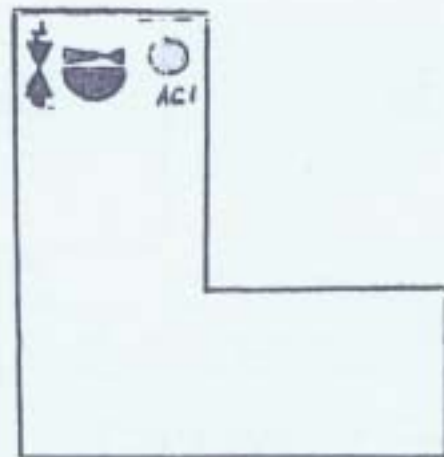

AIR CONDITIONING ROOM.

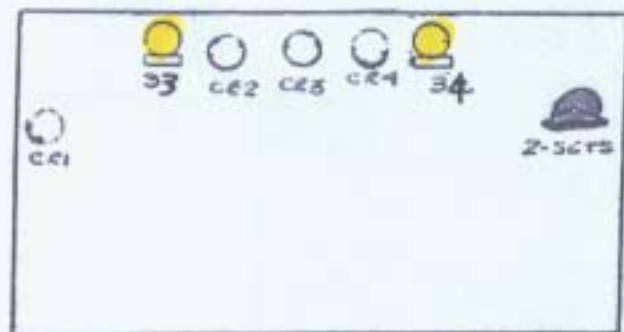

ENGINE CONTROL ROOM.

PRIDE OF LE HAVRE.

Key:-

76Kg HALON BOTTLES (2-OFF). 

6Kg DRY POWDER EXTINGUISHER (6-OFF). 

6Kg CO2 EXTINGUISHER (5-OFF). 

HYDRANT, FIREHOSE AND NOZZLE (3-OFF). 

SELF CONTAINED BREATHING APPARATUS (2-SETS). 

DRENCHER PUMP (1-OFF). 

FIRE AND BILGE PUMP (1-OFF): 

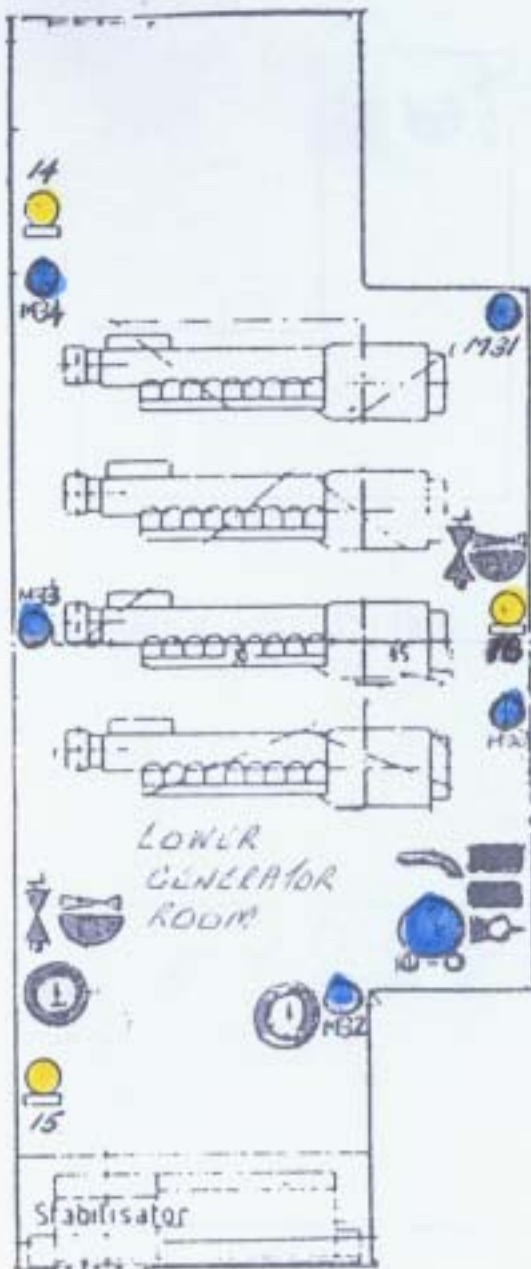



LOWER GENERATOR ROOM.

UPPER GENERATOR ROOM AND W/S.

Key:-

76Kg HALON BOTTLES (10-OFF). 

6Kg DRY POWDER EXTINGUISHER (10-OFF). 

HYDRANT, FIREHOSE AND NOZZLE (4-OFF). 

FOG LANCE (2-OFF).  FIREPROOF BLANKET (1-OFF). 

50Kg DRY POWDER EXTINGUISHER TROLLEY (1-OFF). 

FIRE AND PISTON BILGE PUMP (1-OFF). 

FRESH WATER TOP UP PUMP FOR FIRE MAIN (1-OFF): 

FOAM APPLICATOR (1-OFF).  FOAM COMPOUND 20LTRS (1-OFF). 



TITLE: SAFETY ITEMS LOCATION.

PRIDE OF LE HAVRE.

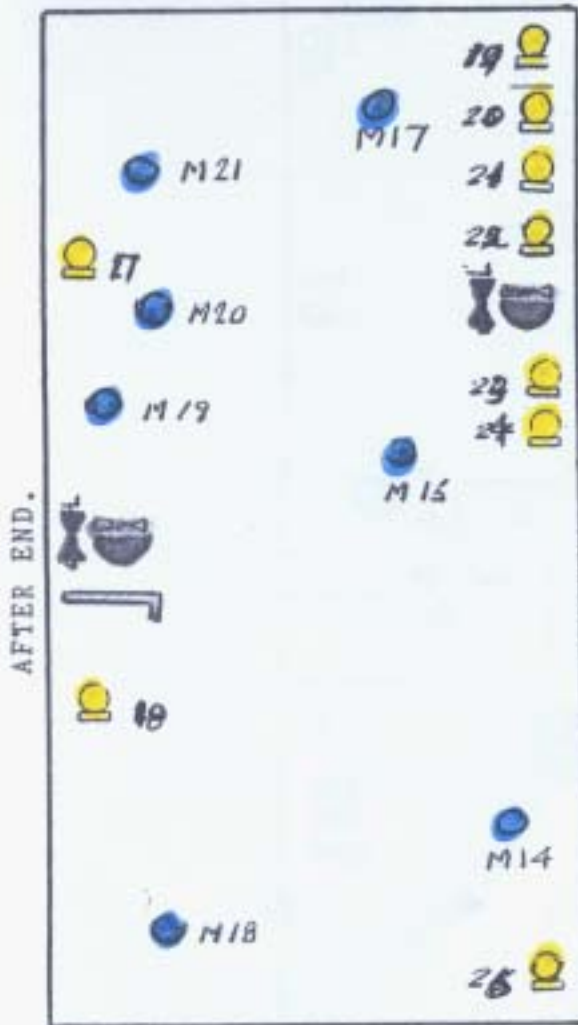



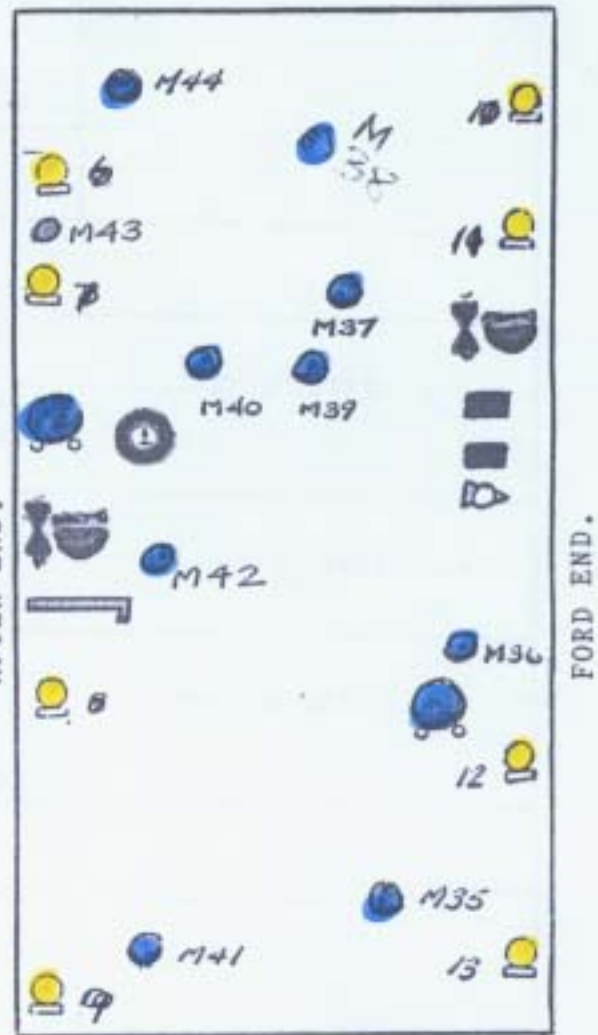





UPPER MAIN ENGINE ROOM.

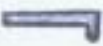

LOWER MAIN ENGINE ROOM.

Key:-

- 76Kg HALON BOTTLES (17-OFF). 
- 50Kg DRY POWDER TROLLEY (2-OFF). 
- 6Kg DRY POWDER EXTINGUISHER (22-OFF). 
- PORTABLE FOAM APPLICATOR (1-OFF). 
- 20 LTR FOAM COMPOUND (40 LTRS). 
- HYDRANT, FIREHOSE AND NOZZLE (4-OFF). 
- FOG LANCE (2-OFF). 
- FIRE AND BILGE PUMP (1-OFF). 



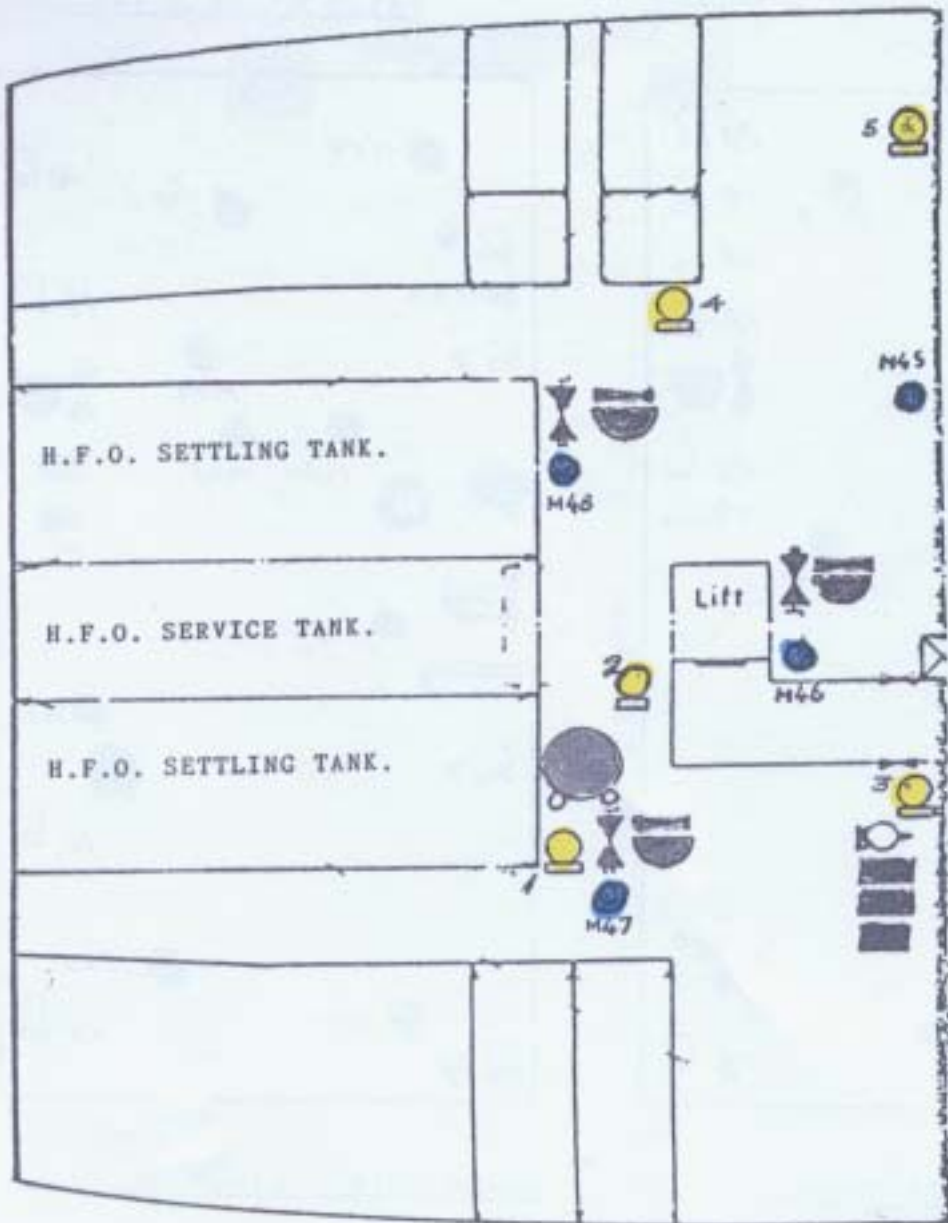



TITLE: SAFETY ITEMS LOCATION.



PRIDE OF LE HAVRE.

PURIFIER ROOM.

Key:-

- 76Kg HALON BOTTLES (5-OFF). 
- 50Kg DRY POWDER TROLLEY (1-OFF). 
- 6Kg DRY POWDER EXTINGUISHER (4-OFF). 
- PORTABLE FOAM APPLICATOR (1-OFF). 
- 20LTR FOAM COMPOUND (60 LTRS). 
- HYDRANT, FIREHOSE AND NOZZLE (3-OFF). 

**4. Detail of Thermal Oil Pump.**



## 0 General

Centrifugal pumps will give trouble-free, satisfactory service if they are properly installed and maintained.

Follow the instructions in this manual carefully. Do not run the pumps under operating conditions which may differ from those specified by us.

This manual does not take into account any site safety regulations which may apply. The site manager or site operator is responsible for notifying our erection staff of any such regulations and ensuring they are complied with.

The nameplate attached to the pump indicates the type series/size, the essential operating data, ident no., impeller diameter, design, serial no., and the label at the volute casing shows the type series/size, impeller diameter, design (e.g. EN 50-250 60 S4 = ETANORM SY 50-250, impeller diameter 260 mm, mechanical seal hard carbon/chrome steel/Viton). Please always state these data in case of inquiries, supplement orders and especially when ordering spare parts.

### N.B.

Do not exceed the capacity, speed, pressure and temperature limits laid down on the nameplate. You must follow the instructions in this manual or the contract documents. You must keep to the specified electric connection values as well as the installation and maintenance instructions. Non-compliance with the above can overload the pumpset and also cause material damage and personal injury.

### General

The descriptions and instructions in this manual refer to the standard model. The manual does not cover all design details and variants or eventualities which might occur during installation, operation or maintenance.

The equipment must only be handled by skilled personnel. For information or instructions not given in this manual, contact KSB.

The manufacturer accepts no liability if the instructions in this manual are not complied with.

### 0.1 Handling

When handling the complete pumpset, attach ropes to the pump and motor as shown (not through the motor eyebolt).

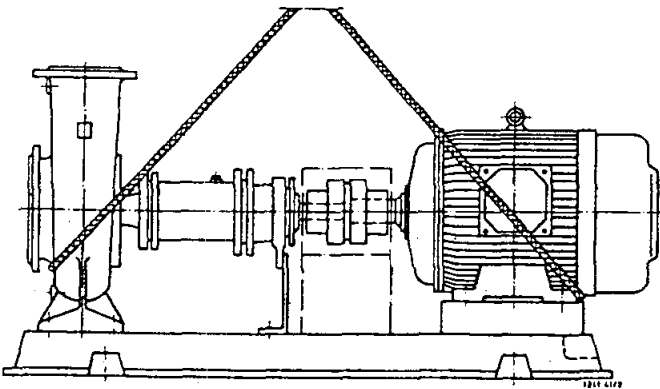

Fig. 1 Pump and motor on common baseplate

## 1 Installation

(Installation on Site)

### 1.1 Foundation

Make sure the concrete foundation has set hard before mounting the pumpset. The surface of the foundation must be completely horizontal and perfectly flat.

### 1.2 Mounting

Position the pumpset on the foundation and align using a precision spirit level (on the shaft/discharge nozzle).

Ensure the gap between the two coupling halves is as given on the general arrangement drawing. Always fit shims to the left and right of the anchor bolts near the securing means, between the baseplate/foundation frame and the foundation. If the shims are more than 800 mm apart, position extra shims equi-distant between them. All shims must seat perfectly flush.

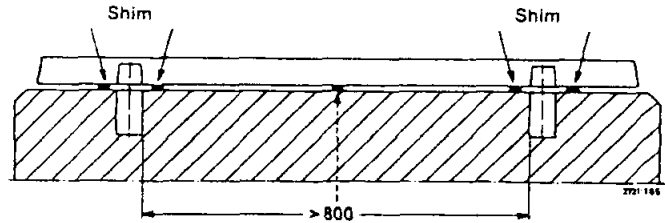

Fig. 2 Fitting shims

Uniformly tighten up securing means.

Grout in the baseplate (non-shrinking mortar is highly recommended) making sure that no cavities remain.

### 1.3 Aligning the Pump and Motor

After the baseplate has been fixed in position carefully check the coupling and, if necessary, realign the pumpset (on the motor). The coupling must also be checked and the pumpset realigned even if the pump and motor are supplied ready mounted on a common baseplate.

The pumpset can be considered correctly aligned when the gap between each shaft and a straight edge placed axially over both coupling halves is the same at all points on the circumference.

Furthermore, the gap between the two coupling halves must be the same at all points on the circumference; this can be measured using calipers or a feeler gauge (see Figs. 3 and 4).

Straight edge

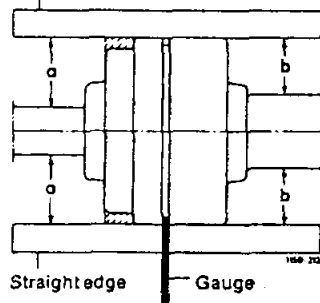

Fig. 3 Aligning a non-spacer type flexible coupling

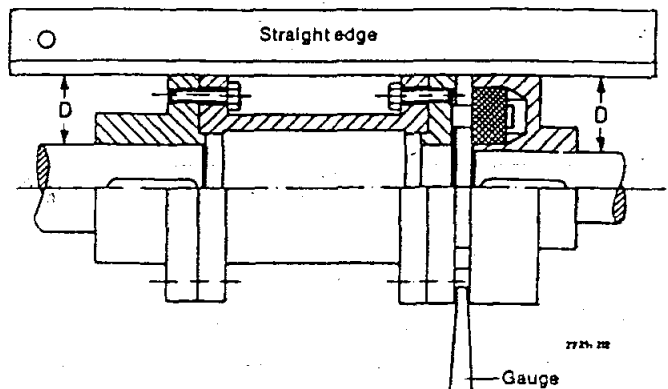

Fig. 4 Aligning a flexible spacer coupling

The axial and radial deviation between the two coupling halves must not exceed 0,1 mm.

#### 1.4 Installation Area

The volute casing and discharge cover take on roughly the same temperature as the product.

The discharge cover, bearing bracket and bearing housing must not be insulated.

The surface temperature of the bearing housing may go as high as 90 °C, so take all necessary precautions to prevent the operating personnel being burned.

#### 1.5 Connecting the Piping

Never use the pump as an anchorage point for the piping.

Positive suction lines should be run with a downwards slope towards the pump.

The pipes should be supported very near the pump and should be connected to it without transmitting any stresses and strains to it. The pump must not bear the weight of the piping.

With short pipework the nominal bore should be the same as or greater than those of the pump nozzles. With long pipework the most economical bore must be established from case to case. We recommend installing non-return devices and shutoff valves, depending on the type of installation.

Thermal expansion of the pipework should be accommodated by suitable means so as not to impose any extra load on the pump.

Before commissioning a new installation, thoroughly clean, flush and blow through all vessels, piping and connections. Welding beads, scale and other impurities frequently only become dislodged after a certain period of time; it is necessary to fit a strainer in the suction line to prevent these entering the pump. The total cross section of the hole in the strainer should be three times the cross section of the piping in order to avoid excessive pressure loss across the strainer due to clogging.

The conical strainer consists of a coarse strainer fronted by a fine strainer with a 2,0 mm mesh and 0,5 mm diameter wire, made of corrosion-resistant material, see DIN 4189.

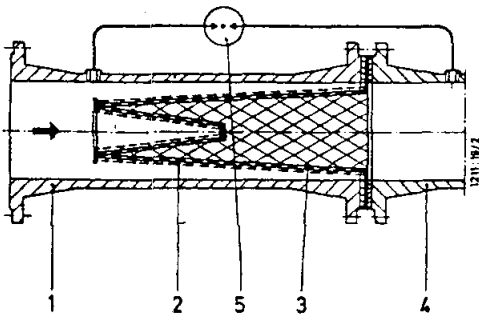

- 1 Strainer holder
- 2 Fine strainer
- 3 Coarse strainer
- 4 Pump suction line
- 5 Differential pressure gauge

Fig.5 Conical strainer for suction line

#### 1.5.1 Auxiliary Connections

The size and location of the leakage connection is shown in the general arrangement drawing or piping diagram.

#### 1.6 Coupling Guard

Safety regulations specify that the pump must be fitted with a coupling guard. If the purchaser specifically states that he does not want us to supply the guard, then this must be provided by the operator.

#### 1.7 Final Check

Recheck alignment as described in 1.3.

It must be possible to rotate the coupling easily by hand. Check the integrity of all connections.

## 2 Startup/Commissioning, Shutdown

### 2.1 Preparations

#### 2.1.1 Lubricant

The bearings are factory packed with grease before despatch.

#### 2.1.2 Shaft Seal

Check seal (see 4.2.1).

#### 2.1.3 Priming the Pump and Associated Checks

Vent and prime the pump and suction line before startup.

The pump can be primed with clean product from the system through the suction line.

Vent the bearing bracket by removing the G 1/4 threaded plug (903) and vent the casing by opening the discharge valve. Rotate the shaft several times by hand during priming to ensure the bracket is completely vented (fluid will escape). Then screw the plug back into the vent hole.

#### 2.1.4 Checking the Direction of Rotation

The bearing bracket must be filled with product before the rotation is checked.

The direction of rotation of the driver must match the arrow on the pump. Check this by switching the pump on then immediately switching it off again.

Fit the coupling guard.

### 2.2 Startup

Start the set up against a closed discharge valve only. Once the pump has reached full speed slowly open the valve and set to the duty point.

However the pump may be started up against an open discharge valve if the circuit is completely full.

**The pump is hot. Do not touch!**

#### N.B.

After the pump has reached its working temperature and/or if leakage occurs, tighten nuts 920.1 and 920.2 with the set disconnected.

### 2.3 Shutdown

Close the discharge gate valve.

The discharge gate valve can remain open if the discharge line incorporates a non-return valve, on condition there is back-pressure.

With the heat source turned off the pump should be able to keep on running until the product has cooled down far enough to avoid temperature gradients inside the pump.

Switch off the motor, making sure the pumpset runs smoothly and evenly down to a stand-still.

If the pumpset is to remain out of service for long periods, close the shutoff valve in the suction line.

### 3 Maintenance and Lubrication

#### 3.1 Supervision of Operation

After partial or complete drainage of the pump, top up the bearing bracket (section 2.1.3).

**N.B.**

**An inadequately filled bracket can destroy the bearing.**

The pump must run quietly and evenly at all times. Do not run the pump for a long period against a closed discharge valve.

The mechanical seal experiences minor leakage or no visible leakage (flashing) during operation. It is maintenance-free.

Keep an eye on the suction strainer and clean it whenever it shows signs of clogging to prevent the absolute pressure in the bearing bracket exceeding 0,5 bar (exceeding this level could cause the bearing to run dry).

The bearing bracket must be kept free from dirt, in order to make sure that the heat to the sealing chamber is reduced by the motor cooling air.

Start up and shut down standby pumps once a week to keep them ready for operation. Check the integrity of the auxiliary connections.

Flexible parts of the coupling which show signs of wear should be replaced in good time.

#### 3.2 Lubrication and Grease Change

##### 3.2.1 Lubrication

The anti-friction bearings are grease lubricated. See 4.3 for lubricant fill.

##### 3.2.2 Grease Grade/Grease Change

The bearings are packed with a high quality, lithium soap based grease which will last, under normal circumstances, for 15,000 operating hours or 2 years. However, under severe operating conditions such as high ambient temperature, high humidity, dust-laden air, corrosive atmosphere etc., inspect the bearings earlier and clean and repack where appropriate.

Use a lithium soap based grease, resin and acid-free, not liable to crumble, with good rust-preventive properties. It should have a penetration number between 2 and 3, corresponding to a worked penetration between 220 and 250 mm/10. Its drop point must be above 175 °C. The hollow spaces around the bearings must not be more than half-packed with grease.

The bearing temperature may exceed ambient temperature by 50 °C but must not go above 90 °C (measurement taken at outside of bearing housing).

A grease with another soap base can also be used, when required; however, greases of varying soap bases are incompatible, so all traces of the old grease must be removed. The repacking schedule must be changed accordingly.

### 4 Dismantling and Reassembly

#### 4.1 General

**N.B.**

Electric motors with cooling air flowing in axial direction towards the pump side are to be used as driving engines. In case of drive by internal combustion engines, only air-cooled engines can be employed, where the cooling air is drawn in or blown off via the coupling/flywheel.

Before dismantling, make sure the pump is disconnected from the power supply and cannot be switched on accidentally.

The shutoff valves mounted on the suction and discharge lines must be closed and absolutely tight. Outflowing/sputtering hot oil catches fire spontaneously. The operator guarantees the perfect operation of the shutoff valves.

Special care must be taken in case of repair work on pumps installed in a plant at work.

The pump casing must have cooled down to ambient temperature.

The pump casing must be empty and not under pressure.

#### 4.2 Dismantling

1. Detach all auxiliary supply lines.
2. Remove coupling guard.
3. With non-spacer type couplings:  
Disconnect pump from driver and detach from baseplate.
4. With spacer couplings:  
The volute casing can remain on the baseplate and in situ in the piping during dismantling.
- 4a. Remove spacer.
- 4b. Detach support foot (183) from baseplate and undo discharge cover hex. nuts (920.1).
- 4c. Withdraw bearing bracket complete with discharge cover and rotor.

**N.B.**

With larger pumps, suspend or support discharge cover to prevent the rotating assembly from falling over.

5. Pull half coupling from shaft. Use an extractor otherwise the carbon bearing could be damaged. Remove key (940.2).

If the pump has been in operation for a long time some parts may be hard to move. So you should use a brand name penetrating oil or suitable pull-off device.

**Under no circumstances use force.**

6. Dismantle the pump in the sequence shown in the exploded view on page 7.

We recommend placing a drip tray underneath the length of the bracket to catch the product.

#### 4.2.1 Mechanical Seal

To replace the mechanical seal it is necessary to dismantle the pump.

#### 4.3 Deep Groove Ball Bearing/Lubricant Fill

Shaft 1)	Symbol	Lubricant fill per bearing
25	6305 Z C3	5 g approx.
35	6307 Z C3	10 g approx.
55	6311 Z C3	15 g approx.

1) See 4.5.4 for correlation between shaft and pump size.

#### 4.4 Reassembly

##### 4.4.1 Pump

Reassemble in accordance with standard engineering practice.

Reassemble in the reverse order to dismantling. Make sure you reassemble in the right sequence.

**N.B.**

- Place gasket (400.1) on discharge cover seating face to prevent it slipping out of position.
- Renew all gaskets involved in dismantling.
- Use specified deep groove ball bearing (321) only.
- Pack bearing with grease (see 4.3)
- When fitting the deep groove ball bearings, ensure the side with the shield ring abuts at the pump side (Fig. 6).

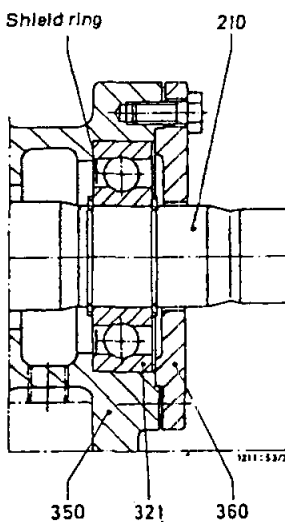

Fig. 6 Mounting the deep groove ball bearing

**N.B.**

**Replacing the plain bearing:**

— **Removing the shaft with bearing sleeve and bearing bush**

Remove the shaft (210) together with bearing sleeve (529) and bearing bush (545) from the bearing bracket (330).  
Press the bearing sleeve from the shaft.

Check that the shaft surface, where the sleeve was, is in perfect condition.

If this area is worn, fit a new shaft.

Check shaft radial runout (permissible deviation 0,03 mm).

— **Fitting the bearing bush and bearing sleeve**

Carefully press the bearing bush into the bearing bracket until it abuts.

Heat the bearing sleeve up to 250 °C to 300 °C in a furnace and slide over the shaft. The sleeve shoulder must point towards the coupling.

On the impeller side, the sleeve must be flush against the shaft shoulder.

Machine the shrunk-fit bearing sleeve to the "as-new" size X (surface quality ▽▽▽).

Shaft 1)	Oversize bearing sleeve (as-delivered condition)	As-new dimension X	Tolerance on as-new dimension X
25	Ø 45,3 – 0,1	Ø 45 d6	Ø 45 – 0,080 – 0,096
35	Ø 55,3 – 0,1	Ø 55 c9	Ø 55 – 0,140 – 0,214
55	Ø 63,3 – 0,1	Ø 63 c9	Ø 63 0,140 – 0,214

1) See 4.5.4 for correlation between shaft and pump sizes.

— If the area between the impeller neck and casing wear ring is worn causing an excessive sealing gap clearance, it is necessary to replace the casing wear rings (502.1 and 502.2 if fitted). The as-new clearance between casing wear ring and impeller is 0,3 mm on diameter.

**4.4.2 Mechanical Seal**

Reassemble in reverse order to dismantling.

When fitting a mechanical seal bear the following points in mind:

Maximum care and maximum cleanliness are mandatory.

Do not remove the guard on the seal faces until just before fitting.

The seal faces and O-rings must not be damaged.

Clean or carefully remove any deposits from the shaft and bearing housing.



#### 4.5 Spare Parts

##### 4.5.1 Ordering Spare Parts

The following information which may be taken from the nameplate of the pump, e.g.:

Type ETANORM SY 50-250  
 Ident no. 48 818 231  
 Material S4  
 Serial no. 4-107-451 777  
 or from the volute casing, e.g. EN 50-250 60 S4  
 must always be indicated in spare part orders.

##### 4.5.3 Stocking a Set of Spare Parts, ready assembled, comprising:

Part no.	Part designation	Part no.	Part designation
210	1 Shaft with hex. nut (920.3) and key (940.1)	411	1 Gasket
321	1 Deep groove ball bearing	433	1 Mechanical seal, complete
330	1 Bearing bracket	507	1 Thrower
350	1 Bearing housing	529	1 Bearing sleeve
360	1 Bearing cover	545	1 Bearing bush
400.3/4	2 Gaskets	932	2 Circlips

##### 4.5.2 Recommended List of Spare Parts for 2 Year's continuous Operation acc. to VDMA 24 296

Part no.	Part designation	No. of pumps (including stand-by pumps)						
		2	3	4	5	6 and 7	8 and 9	10 and more
		Quantity of spare parts						
210	Shaft with bearing sleeve (529), hex. nuts (930.3) and key (940.1)	1	1	2	2	2	3	30 %
230	Impeller (incl. casing wear ring 502.2)	1	1	1	2	2	3	30 %
321	Deep groove ball bearing	1	1	2	2	3	4	50 %
330	Bearing bracket with bearing bush (545)	—	—	—	—	—	1	2 off
350	Bearing housing	—	—	—	—	—	1	2 off
433	Mechanical seal, complete	2	3	4	5	6	7	90 %
502.1	Casing wear ring	2	2	2	3	3	4	50 %
	Gaskets (set)	4	6	8	8	9	12	150 %

##### 4.5.4 Interchangeability of Pump Components

Pump sizes	Shaft	Part designation														
		Volute casing	Discharge cover	Support foot	Shaft	Impeller	Deep groove ball bearing	Bearing bracket	Bearing housing	Bearing cover	Mechanical seal	Casing wear ring, suction side	Casing wear ring, discharge side	Thrower	Bearing sleeve	Bearing bush
		Part no.	102	163	183	210	230	321	330	350	360	433	502.1	502.2	507	529
32-125.1	25		1	1	1		1	1	1	1	1	1	x	1	1	1
32-160.1	25		1	2	1	1	1	1	1	1	1	1	3	1	1	1
32-200.1	25		2	3	1	2	1	1	1	1	1	1	3	1	1	1
32-160	25		1	2	1	1	1	1	1	1	1	1	3	1	1	1
32-200	25		2	3	1	2	1	1	1	1	1	1	3	1	1	1
40-160	25		1	2	1		1	1	1	1	1	2	3	1	1	1
40-200	25		2	3	1		1	1	1	1	1	3	1	1	1	1
40-250	25		3	4	1		1	1	1	1	1	2	10	1	1	1
50-160	25		1	3	1		1	1	1	1	1	3	3	1	1	1
50-200	25		2	3	1		1	1	1	1	1	3	3	1	1	1
50-250	25		3	4	1		1	1	1	1	1	3	10	1	1	1
50-315	35		7	7	2		2	2	2	2	2	4	11	2	2	2
65-160	25		4	3	1		1	1	1	1	1	4	5	1	1	1
65-200	25			4	1		1	1	1	1	1	4	5	1	1	1
65-250	35			5	2		2	2	2	2	2	5	5	2	2	2
65-315	35		7	7	2		2	2	2	2	2	5	11	2	2	2
80-160	25		4	4	1		1	1	1	1	1	6	5	1	1	1
80-200	35		5		2		2	2	2	2	2	6	11	2	2	2
80-250	35		6	5	2		2	2	2	2	2	6	11	2	2	2
80-315	35		7	6	2		2	2	2	2	2	6	11	2	2	2
80-400	55		9	9	3		3	3	3	3	3	11	12	3	3	3
100-160	35		5	5	2		2	2	2	2	2	7	11	2	2	2
100-200	35		5	5	2		2	2	2	2	2	7	11	2	2	2
100-250	35		6	7	2		2	2	2	2	2	7	11	2	2	2
100-315	35		7	6	2		2	2	2	2	2	7	11	2	2	2
125-200	35			8	2		2	2	2	2	2	8		2	2	2
125-250	35			6	2		2	2	2	2	2	8		2	2	2
125-315	55		8	9	3		3	3	3	3	3	8	12	3	3	3
125-400	55		9	8	3		3	3	3	3	3	8	12	3	3	3
150-315	55		8	9	3		3	3	3	3	3	9	12	3	3	3
150-400	55		9	8	3		3	3	3	3	3	9	12	3	3	3

**4.6 General Arrangement Drawings**  
with mechanical seal, material code S4, G4

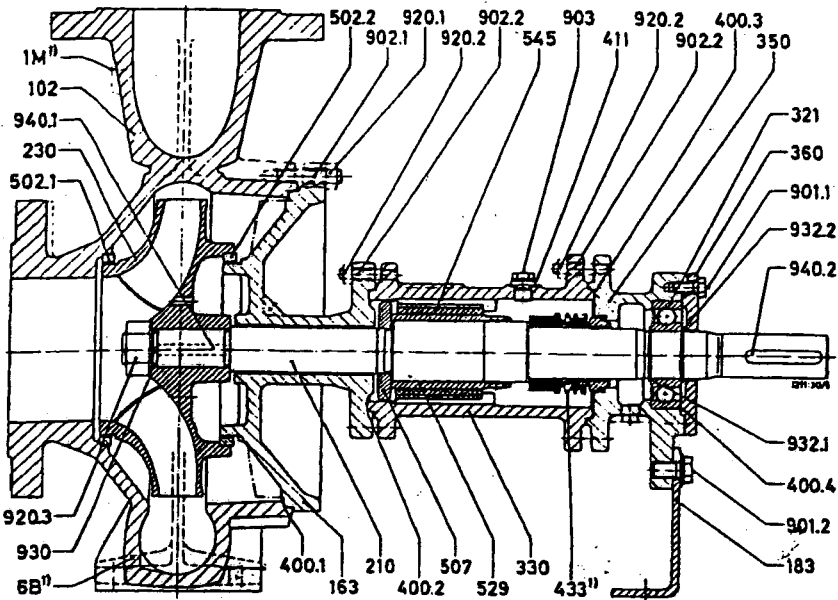

with mechanical seal,  
material code S6

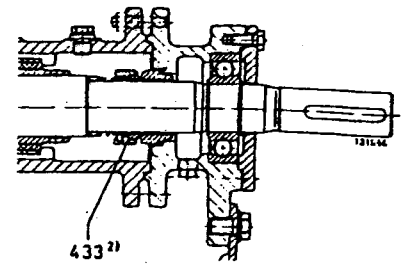

Impeller mounting, shaft unit 25<sup>6)</sup>  
Impeller unbalanced for pump size  
32-125.1

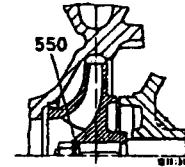

**4.7 Exploded View**

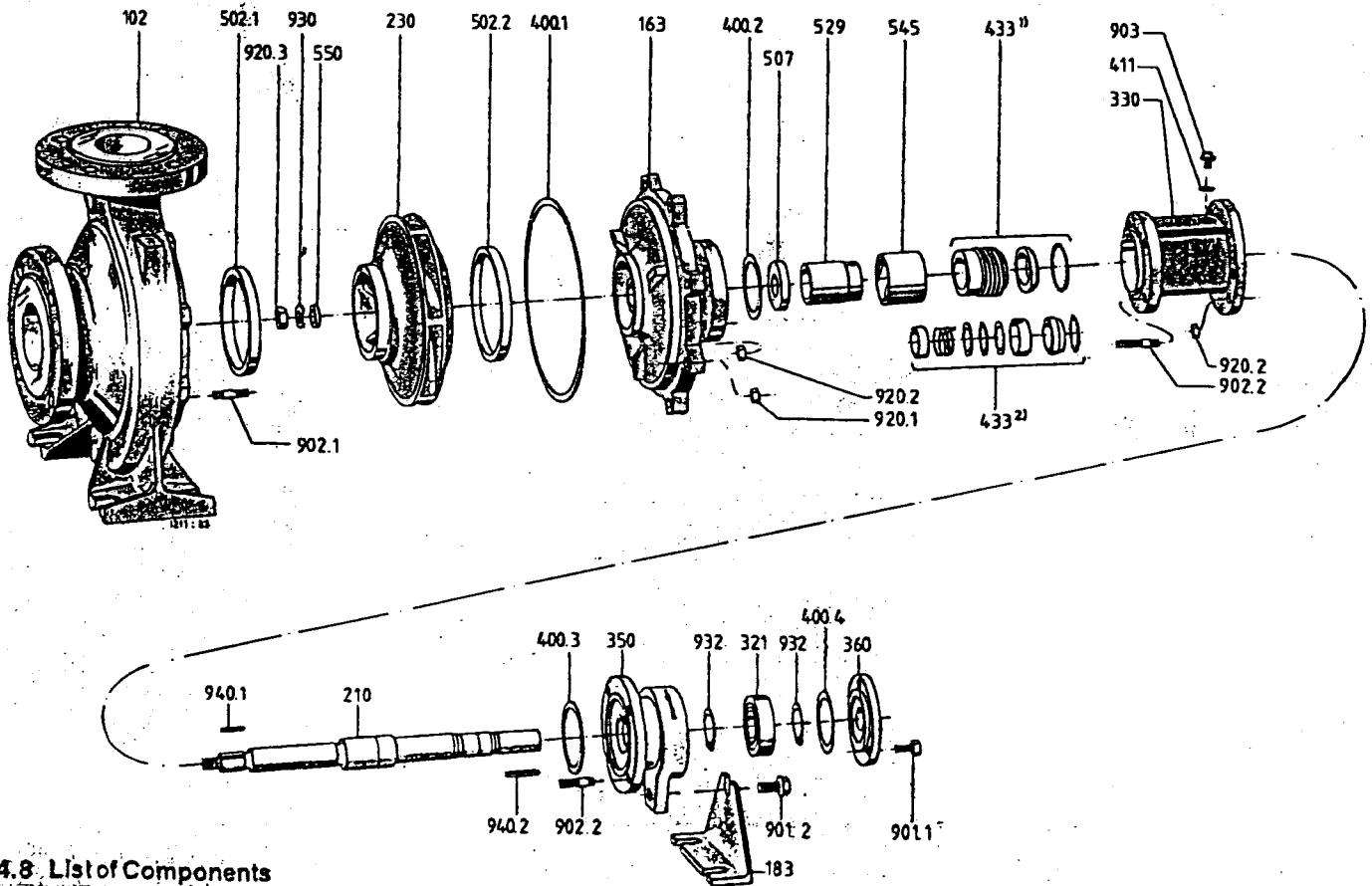

**4.8 List of Components**

Part no.	Part designation	Part no.	Part designation	Part no.	Part designation
102	Volute casing	400.1-4	Gasket	902.1/2	Stud
163	Discharge cover	411	Gasket	903	Threaded plug
183	Support foot	433	Mechanical seal	920.1-3	Hex. nut
210	Shaft	502.1/2	Casing wear ring	930	Spring washer
230	Impeller	507	Thrower	932.1/2	Circlip
321	Deep groove ball bearing	529	Bearing sleeve	940.1	Key <sup>1)</sup>
330	Bearing bracket	545	Bearing bush	940.2	Key
350	Bearing housing	550	Disc <sup>4)</sup>	1 M	Pressure gauge connection <sup>3)</sup>
360	Bearing cover	901.1/2	Hex. head bolt	8 B	Casing drain <sup>3)</sup>

<sup>1)</sup> On ETANORM SY, GY, GH  
<sup>2)</sup> On ETANORM SH

<sup>3)</sup> On ETANORM SY connection not drilled as a standard  
<sup>4)</sup> Applies only to pumps with size 25 shaft

<sup>5)</sup> 2 off on pump sizes with size 55 shaft  
<sup>6)</sup> See 4.5.4 for correlation between shaft and pump sizes

## 5 Faults

Pump delivers insufficient liquid	Motor overloaded	Excessively high pump discharge pressure	Bearings overheating	Pump leaks	Excessive shaft seal leakage	Rough pump running	Excessive temperature rise inside the pump	Cause	Remedy <sup>1)</sup>
•								Pump generates excessively high differential pressure	Reset duty point
•								Excessively high back pressure	Fit larger impeller(s) <sup>2)</sup> Increase speed (applies to turbine driven and I.C. engine driven pumps) Check installation for contamination
•						•	•	Pump and/or piping inadequately vented or primed	Vent or prime pump and piping completely Unclog vent hole
•								Suction line or impeller clogged	Remove deposits in pump and/or piping
•								Formation of air pockets in piping	Alter piping layout If necessary fit a vent valve
•						•	•	NPSH <sub>plant</sub> (inlet) too low	Correct liquid level Mount pump at lower level Fully open suction side shutoff valve Modify suction line in the event of excessive suction line friction loss Check suction strainers Make sure permissible rate of pressure decrease is not exceeded
•								Reverse rotation	Change over two phases of the power supply cable
•								Speed too low <sup>2)</sup>	Increase speed
•						•		Excessive wear of pump internals	Replace worn components
•	•					•		Pump back pressure is lower than specified in purchase order	Adjust duty point accurately In case of persistent overloading, turn down impeller, if necessary <sup>2)</sup>
•								Specific gravity or viscosity of fluid pumped is higher than specified in purchase order <sup>2)</sup>	
•	•							Excessive speed	Reduce speed <sup>2)</sup>
				•				Defective seal	Renew seal between volute casing and discharge cover
					•			Worn shaft seal	Replace
			•		•	•		Pumpset misaligned	Rectify
			•		•	•		Pump warped or resonance vibrations in the piping	Check piping connections and pump fixing bolts, reduce gap between pipe supports, if necessary Support piping using anti-vibration material
			•					Excessive axial thrust <sup>2)</sup>	Clean out balance holes in impeller Fit new casing wear rings
			•			•		Too much, too little or unsuitable lubricant	Reduce quantity of or top up lubricant or change lubricant
			•					Specified coupling gap not respected	Restore correct coupling gap in accordance with installation plan
•	•							Motor runs on two phases	Replace defective fuse Check electrical connections
						•		Rotor unbalanced	Clean rotor Rebalance rotor
						•		Defective bearings	Fit new bearings
						•	•	Inadequate flow	Increase minimum flow

<sup>1)</sup> The pump should be made pressureless before attempting to remedy faults in parts under pressure

<sup>2)</sup> Please refer to KSB



Klein, Schanzlin & Becker  
Aktiengesellschaft  
6710 Frankenthal (Pfalz)

**KSB pumps**

Standard Pumps Division

Johann-Klein-Straße 9  
Postfach 225  
D-6710 Frankenthal (Pfalz)

Telefon: (06233) 86-0  
Telex: 4 65 211-0 KS  
Telefax: (06233) 86 33 11

# HTI

## Pumpeneinbauvorschrift Pump installation instruction

Zehng-Nr.: 6.009

Auftrag-Nr.:

Blatt-Nr.: 1 Anzahl:

Datum: 07. 85 Name: *App*

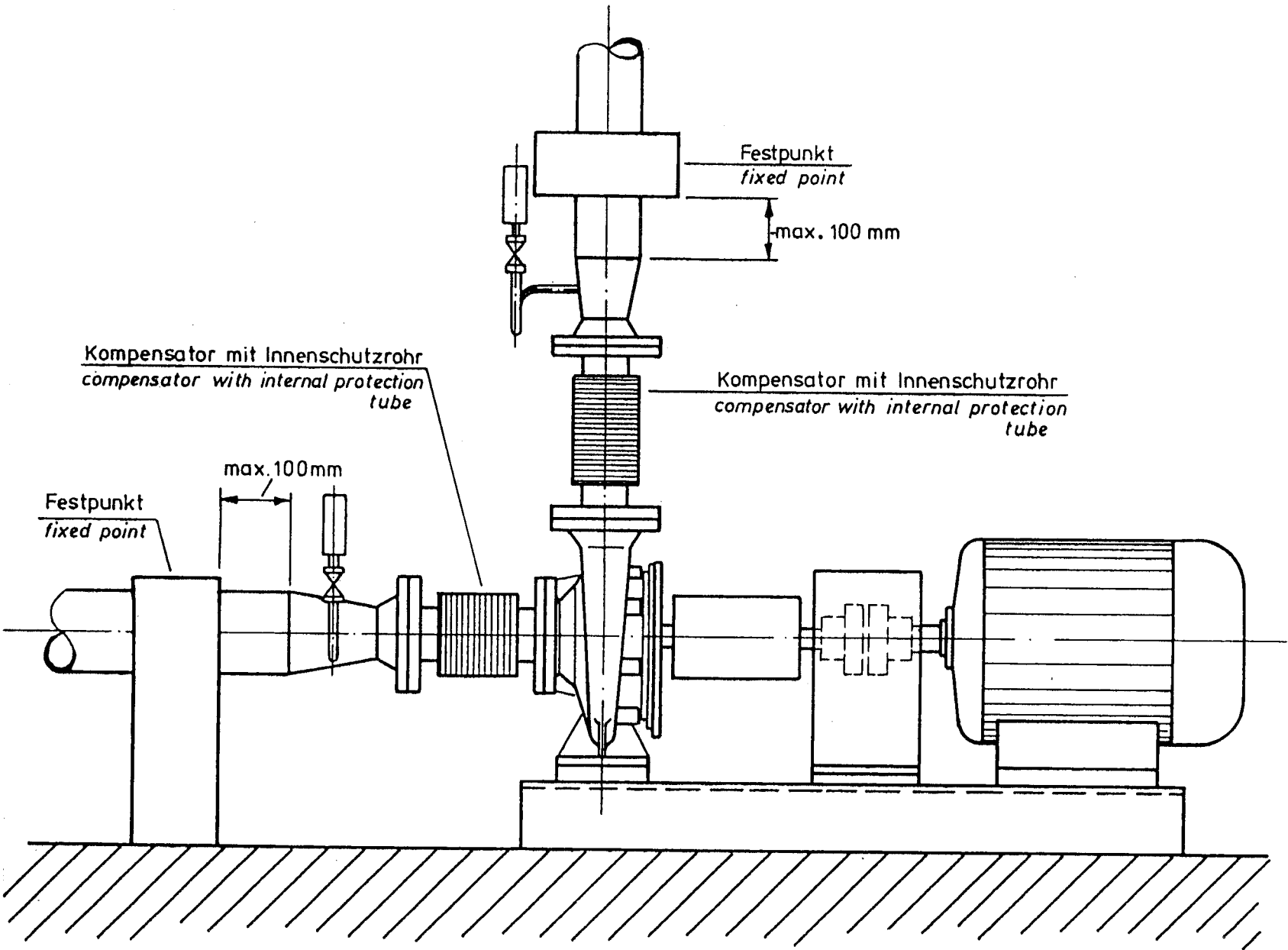

**5. Thermal Oil Product detail.**

# Shell Marine Products Limited

15 July 1997

**Direct lines:**

**Tel:** 0171 546 2472

**Fax:** 0171 546 4155

**Your ref:**

**Our ref:** UKT/1

Dear Steve

In line with our policy of updating Customer Lubrication Surveys when new information or new products are available, here are the updated Lubrication Surveys for the above named vessel.

If there are any additions or changes to the machinery on this vessel, I would be grateful for this information to enable me to update future Surveys.

Yours sincerely

**Shell Marine Products Limited**



J. Hammett  
Technical Support Engineer

# Shell Thermia Oil B

## Heat transfer fluid



Shell Thermia Oil B is based on a blend of carefully selected, solvent refined, high viscosity index mineral oils chosen for their ability to provide superior performance in indirect closed fluid heat transfer systems operating at bulk temperatures up to 320°C.

---

### Applications

- Mineral oil heat transfer systems

### Performance Features

- *High heat transfer coefficients*
- *High oxidation and thermal stability*
- *Good viscosity/temperature characteristics*
- *Low vapour pressure*
- *Non-corrosive*
- *Non-toxic*

### Thermal Stability

Mineral oils are subject to two forms of degradation at elevated temperatures:

1. Cracking or the breaking down of hydrocarbon molecules by heat. Large molecules rupture into smaller molecules and so on. Some appear as volatile gases, while others are unstable and polymerise into non-soluble deposits.
2. Oxidation or the reaction of hydrocarbon oil with atmospheric oxygen. At room temperature this reaction occurs very slowly, but it accelerates rapidly with increasing temperature. Oxidation produces acidity in the oil, some non-soluble contaminants and is usually accompanied by an increase in viscosity.

Shell Thermia Oil B has exceptionally good thermal stability at bulk oil temperatures up to 320°C. The rates of cracking and oxidation are very small, giving maximum oil life. This assumes an efficient fluid heater with good pump circulation so that film temperatures on the heater surfaces do not exceed 340°C.

### Service Life

The life of Shell Thermia Oil B depends on the design and usage of the system. If the system is well designed, and not subjected to abnormal workloads, the life can be for many years.

It is important to monitor oil condition regularly as rates of change in physical characteristics are more significant than actual values. A sample should be taken from a newly filled system about one week after start-up to establish a datum. Further samples should then be taken every 6 months and the results compared with the previous samples.

The properties that should be monitored are viscosity, acidity, flash point (open and closed) and insolubles content.

### Design and Operating Notes

A potential source of damage to a heat transfer oil is the heater. To avoid trouble, the circulation pump should be capable of producing a fully turbulent oil flow through the heater at surface speeds between 2 and 3.55 metres per second according to surface geometry. The heat flux should be kept to a minimum to reduce film temperature. The maximum film temperature for Shell Thermia Oil B is 340°C.

The heater should contain a minimum of refractory in its construction so that soak-back into the oil is reduced should the circulation pump fail. Direct flame impingement onto the oil tubes should be avoided so as to prevent local overheating and excessive film temperatures.

An expansion tank is necessary to allow for the change in fluid volume upon heating or cooling. The volume of mineral oil at 300°C is about 20 per cent greater than at room temperature. The tank should be large enough to accept the total heat expansion within its own dimensions. It should be the highest point in the oil circuit and be connected to the system on the pump suction side to provide an adequate static head. Circulation through the expansion tank can be prevented by some means such as a U-bend below the point where it joins the main circuit.

The general system pipework should contain adequate ventilation to reduce vapour and air locks during initial start-up. If pressure is necessary it is best to avoid water as its removal before commissioning can be a long

and difficult process. If any moisture is left in the system, the new oil should be heated slowly up to about 110°C with continuous venting. The temperature can then be raised slowly to working temperature with periodic bleeding of vapour.

The whole system should be instrumented to monitor oil temperature and flow at critical points, i.e. either side of the heater. It should also have fail-safe devices so that pump failure or excessive temperatures trip the heater.

Constant flow through the heater should be maintained regardless of the conditions at the process vessel and this can be achieved by a by-pass line across the process vessel containing a constant pressure valve capable of taking full oil flow.

### Health & Safety

Shell Thermia Oil B is unlikely to present any significant health or safety hazard when properly used in the recommended application, and good standards of industrial and personal hygiene are maintained.

Avoid contact with skin. Use impervious gloves with used oil. After skin contact, wash immediately with soap and water.

For further guidance on Product Health & Safety refer to the appropriate Shell Product Safety Data Sheet

### Protect the environment

Take used oil to an authorised collection point. Do not discharge into drains, soil or water.

### Advice

Advice on applications not covered in this leaflet may be obtained from your Shell Representative

## Typical Physical Characteristics

Shell Thermia Oil B	
<b>Kinematic Viscosity</b>	
@ 0°C cSt	229
40°C cSt	25.0
100°C cSt	4.65
200°C cSt	1.2
300°C cSt	0.5
(IP 71)	
<b>Viscosity Index</b>	100
(IP 226)	
<b>Density @ 15°C kg/l</b>	0.868
(IP 365)	
<b>Flash Point °C</b>	220
(Pensky-Martens Closed Cup)	
(IP 34)	
<b>Flash Point °C</b>	232
(Cleveland Open Cup)	
(IP 36)	
<b>Fire Point °C</b>	255
(ISO 2592)	
<b>Pour Point °C</b>	-18
(IP 15)	
<b>Initial Boiling Point °C</b>	Above 355
<b>Coefficient of Thermal Expansion per °C</b>	0.00076
<b>Autogenous Ignition Temperature °C</b>	375
<b>Neutralisation Number mg KOH/g</b>	0.05
(IP 139)	

These characteristics are typical of current production. Whilst future production will conform to Shell's specification, variations in these characteristics may occur.





# Product Safety Data Sheet

SHELL THERMIA OIL B

Data Sheet No. L60410 Revision : 29 01 98

REPLACES L60410 : 01 11 95

This data sheet has been prepared in accordance with the requirements of the Data Sheet Directive 91/155/EEC.

## RECOMMENDED USES

Shell Thermia Oil B is recommended for use as :

an industrial heat transfer fluid.

If Shell Thermia Oil B is used for a purpose not covered in this section, Shell UK Ltd would be grateful to receive information on the application.

## KNOWN MISUSES/ABUSES

Shell Thermia Oil B is not to be used as :

None known.

The disposal of Shell Thermia Oil B to soil, watercourses and drains is a legal offence.

## 1: IDENTIFICATION OF THE SUBSTANCE/PREPARATION AND OF THE COMPANY/UNDERTAKING

PRODUCT :	SHELL THERMIA OIL B
COMPANY :	SHELL U.K. LIMITED,
ADDRESS :	SHELL-MEX HOUSE, STRAND, LONDON. WC2R 0DX
TELEPHONE :	0171-257-3000
EMERGENCY TELEPHONE NUMBER :	AS ABOVE

## 2: COMPOSITION/INFORMATION ON INGREDIENTS

Shell Thermia Oil B is a highly refined mineral oil manufactured from crude petroleum oil. It is identified as a SUBSTANCE in EINECS and covered by the following EINECS and CAS Numbers.

EINECS NUMBER 265-169-7

CAS NUMBER 64742-65-0

Distillates (petroleum), solvent-dewaxed heavy paraffinic.

A complex combination of hydrocarbons obtained by removal of normal paraffins from a petroleum fraction by solvent crystallization. It consists predominantly of hydrocarbons having carbon numbers predominantly in the range of C20 through C50 and produces a finished oil with a viscosity not less than 100 SUS at 100 Deg. F. (19 cSt at 40 Deg. C.).

Exposure limit values exist for the following constituents:

Mineral Oil.

## 3: HAZARD IDENTIFICATION

Shell Thermia Oil B has a low coefficient of friction presenting a slip hazard.

Shell Thermia Oil B is not classified as dangerous for supply or conveyance. The DMSO extract by IP 346 of the oil is less than 3%. Consequently it is not classified as a carcinogen.

Shell Thermia Oil B is a mineral oil, to which an exposure limit applies. Prolonged and repeated skin contact with mineral oil causes defatting of the skin and may give rise to skin conditions including dermatitis.

Shell Thermia Oil B will not biodegrade in anaerobic conditions and, hence, can be persistent. It contains components which have a high potential to bioaccumulate. Owing to its physical properties spillages can lead to fouling of flora, fauna and the environment.

#### 4: FIRST AID MEASURES

##### INHALATION

Remove to fresh air. If rapid recovery does not occur, obtain medical attention.

##### SKIN

Skin contact does not normally require first aid, but oil soaked clothing should be removed, and contaminated skin washed with soap and water. If persistent irritation occurs, medical advice should be sought without delay.

Where a high pressure injection injury has occurred, medical attention should be obtained immediately. Show this Data Sheet to the physician drawing attention to "Notes for Doctors" in Section 11 below.

##### EYES

Flush the eye with copious quantities of water. If irritation persists refer for medical attention.

##### INGESTION

###### **DO NOT INDUCE VOMITING**

If ingestion is suspected, wash out the mouth with water, and send to hospital immediately. Show this Data Sheet to the physician drawing attention to "Notes for Doctors" in Section 11 below.

---

#### 5: FIRE-FIGHTING MEASURES

Extinguishants	- Large Fire :	Foam/Water Fog - NEVER USE WATER JET
	- Small Fire :	Foam/Dry Powder/AFFF/CO2/Sand/Earth

---

#### 6: ACCIDENTAL RELEASE MEASURES

##### LAND SPILLAGES

The first concern should be to prevent entry to drains or watercourses.

LARGE SPILLS should be banded by a suitable medium such as sand or earth. The liquid should be reclaimed directly or in an adsorbent medium and then transferred to suitable, clearly marked containers and disposed of in accordance with local byelaws and the requirements of the Environmental Protection Act 1990.

SMALL SPILLS should be soaked up with sand or earth and disposed of as for large spills.

##### MARITIME SPILLAGES

Any spillage of Shell Thermia Oil B which results in overside pollution must be treated in accordance with the guidelines laid down in the respective Vessel Oil Spill Response Contingency Plan, as required by MARPOL 73/78 Annex 1, Regulation 26. Where the vessel is not required to comply with such legislation, the Owner's and/or Charterer's instructions must be followed. In the absence of any other guidelines, any spillage in territorial/coastal waters must be immediately reported to the appropriate maritime authority, e.g. coast guard, the vessel's local agent if applicable, and the vessel's Owner/Charterer. In international waters, any spillage should be reported to the nearest coastal state, and additional guidance should be sought immediately from the vessel's Owner/Charterer.

---

#### 7: HANDLING AND STORAGE

##### HANDLING

Shell Thermia Oil B does not require any special handling techniques, but it should be handled in suitable containers and spillage avoided.

##### STORAGE

The storage of Shell Thermia Oil B is not subject to any special controls or restrictions. It should be stored in properly designed, closable, labelled containers, eg mild steel or high density polyethylene (HDPE).



## 11: TOXICOLOGICAL INFORMATION

### ACUTE HEALTH HAZARDS AND ADVICE

Toxicity following single exposure to high levels (orally, dermally or by inhalation) is of a low order. The main hazards are: in the unlikely event of ingestion, aspiration into the lungs with possible resultant chemically induced pneumonia ; and, if the products are handled under high pressures, of high pressure injection injuries.

### INHALATION

Under normal conditions of use inhalation of vapours is not feasible or likely to present an acute hazard.

#### PRECAUTIONS :

Care should be taken to keep exposures below applicable occupational exposure limits by the use of general or local ventilation. If this cannot be achieved, use of a respirator fitted with an organic vapour cartridge combined with a particulate prefilter.

#### FIRST AID :

Remove to fresh air. If rapid recovery does not occur, obtain medical attention.

### SKIN

Skin contact presents no acute health hazard except in the case of high pressure injection injuries. These can lead to the loss of the affected limbs if not treated immediately and properly.

#### PRECAUTIONS :

Avoid contact with the skin by the use of suitable protective clothing. Where skin contact is unavoidable, a high standard of personal hygiene must be practised. Extreme care must be exercised where the product is likely to be encountered at high pressures, when it is recommended that safe systems of work be employed.

#### FIRST AID :

Skin contact does not normally require first aid, but oil soaked clothing should be removed, and contaminated skin washed with soap and water. If persistent irritation occurs, medical advice should be sought without delay.

Where a high pressure injection injury has occurred, medical attention should be obtained immediately. Show this Data Sheet to the physician drawing attention to "Notes for Doctors" below.

### EYES

Eye contact may cause some discomfort.

#### PRECAUTIONS :

If there is a risk of splashing while handling the liquid, suitable eye protection should be used.

#### FIRST AID :

Flush the eye with copious quantities of water. If irritation persists refer for medical attention.

### INGESTION

The main hazard following ingestion is of aspiration into the lungs during subsequent vomiting.

#### PRECAUTIONS :

Accidental ingestion is unlikely. Normal handling and hygiene precautions should be taken to avoid ingestion.



# Product Safety Data Sheet

---

## **FIRST AID :**

### **DO NOT INDUCE VOMITING.**

If ingestion is suspected, wash out the mouth with water, and send to hospital immediately. Show this Data Sheet to the physician drawing attention to "Notes for Doctors" below.

## **CHRONIC HEALTH HAZARD AND ADVICE**

Prolonged and repeated contact with oil products can be detrimental to health. The main hazards arise from skin contact and in the inhalation of mists. Skin contact under conditions of poor hygiene and over prolonged periods can lead to defatting of the skin, dermatitis, erythema, oil acne and oil folliculitis. Excessive and prolonged inhalation of oil mists may cause a chronic inflammatory reaction of the lungs and a form of pulmonary fibrosis.

## **NOTES FOR DOCTORS**

### **HIGH PRESSURE INJECTION INJURIES**

High pressure injection injuries require surgical intervention and possibly steroid therapy to minimise tissue damage and loss of function. Because entry wounds are small and do not reflect the seriousness of the underlying damage, surgical exploration to determine the extent of involvement may be necessary. Local anaesthetics or hot soaks should be avoided because they can contribute to swelling, vasospasm and ischaemia. PROMPT surgical decompression, debridement and evacuation of foreign material should be performed under general anaesthetic, and wide exploration is essential.

### **INGESTION AND ASPIRATION OF PETROLEUM PRODUCTS**

There may be a risk to health where low viscosity products are aspirated into the lungs following vomiting, although this is uncommon in adults. Such aspiration would cause intense local irritation and chemical pneumonitis. Children, and those in whom consciousness is impaired, will be more at risk. Emesis of lubricants is not usually necessary, unless a large amount has been ingested, or some other compound has been dissolved in the product. If this is indicated - for example, when there is rapid onset of CNS depression from a large ingested volume - gastric lavage under controlled hospital conditions, with full protection of the airway is required. Supportive care may include oxygen, arterial blood gas monitoring, respiratory support and, if aspiration has occurred, treatment with corticosteroids and antibiotics. Seizures should be controlled with Diazepam, or appropriate equivalent drug.

---

## **12: ECOLOGICAL INFORMATION**

The information given below refers to the mineral base oil component, which accounts for 100%, of Shell Thermia Oil B .

### **AIR**

Shell Thermia Oil B is a mixture of non-volatile components, which are not expected to be released to air in any significant quantities.

### **WATER**

If released to water, Shell Thermia Oil B will form a floating layer on the surface and its components will not evaporate or dissolve to any great extent. Dissolved components will be absorbed in sediments. In aerobic water and sediments they will biodegrade slowly, but in anaerobic conditions they will persist. Shell Thermia Oil B is practically non-toxic to aquatic organisms but contains components which have a high potential to bioaccumulate, and has the potential to physically foul aquatic organisms.

### **SOIL**

Small volumes released on land will be absorbed in the upper soil layers and be biodegraded slowly. Larger volumes may penetrate into anaerobic soil layers in which the product will persist and may reach the water table on which it will form a floating layer. The more soluble components may dissolve but their high soil absorption coefficient and the low solubility will prevent significant contamination of ground water.

---

## **13: DISPOSAL CONSIDERATIONS**

Shell Thermia Oil B is a controlled waste and must be disposed of to a licensed waste contractor. If in doubt, seek advice from your Local Authority.

The disposal of mineral oils to sewers, watercourses or land without consent of the Local Water Authority or the National Rivers Authority (NRA) is an offence under the Environmental Protection Act 1990 or the Water Resources Act 1991 or the Water Industry Act 1991.

---

#### 14: TRANSPORT INFORMATION

Not Dangerous for Conveyance

---

#### 15: REGULATORY INFORMATION

This material has been classified according to the requirements of the Dangerous Substances Directive 67/548/EEC as last amended by the 8th Amendment 96/56/EC, the 22nd Adaptation to Technical Progress 96/54/EC, and the Preparations Directive 88/379/EEC as last amended by the 4th Adaptation to Technical Progress 96/65/EC.

Not Dangerous for Supply

Inclusion of substance from which Shell Thermia Oil B is manufactured in national inventories:

EINECS (European Union)	Yes
CSI under TSCA (USA)	Yes
DSL (Canada)	Yes
AICS (Australia)	Yes
ECL (Korea)	Yes
(Phillippines)	Information not available
MITI (Japan)	Yes

---

#### 16: OTHER INFORMATION

##### LEGISLATION

Consumer Protection Act 1987  
Control of Pollution Act 1974  
Environmental Protection Act 1990  
Factories Act 1961  
Health and Safety at Work Act 1974  
Carriage of Dangerous Goods by Road and Rail (Classification, Packaging and Labelling) Regulations  
Chemical (Hazards, Information, and Packaging for Supply) Regulations  
Control of Substances Hazardous to Health Regulations  
Dangerous Substances in Harbour Areas Regulations  
Merchant Shipping (Dangerous Goods and Marine Pollutants) Regulations  
Road Traffic (Carriage of Dangerous Substances in Packages etc.) Regulations  
Road Traffic (Carriage of Dangerous Substances in Road Tankers and Tank Containers) Regulations  
Road Traffic (Training of Drivers of Vehicles Carrying Dangerous Goods) Regulations  
Reporting of Injuries, Diseases and Dangerous Occurrences Regulations  
Special Waste Regulations

##### GUIDANCE NOTES

HS(G)71 The storage of packaged dangerous substances  
EH/40 Occupational Exposure Limits  
EH/58 The Carcinogenicity of Mineral Oils  
MS24 Health surveillance of occupational skin disease

##### OTHER LITERATURE

Concawe Report 86/69 Health Aspects of Worker Exposure to Oil Mists  
Concawe Report 01/97 Petroleum Products - First Aid Emergency and Medical Advice  
Department of the Environment - Waste Management - The Duty of Care - A Code of Practice

##### ADDRESSES

Concawe, Madouplein 1, B-1210 Brussel, Belgium

---

**6. Photographs**



Fig 1      General view of No 2 Thermal Oil Pump.  
Return lines the right, discharge lines on the left.





Fig 2 Close-up view of No 2 starboard thermal oil pump showing shrouded coupling and bearing bracket.



Fig 3 General view of shaft, impeller, bearing bracket, and drive coupling before being stripped for inspection.



Fig 4 Close-up view of discharge cover showing heavy face plate wear caused by movement of shaft forward and contact between thrower and discharge cover.



Fig 5 Close-up of impeller shaft thrower showing corresponding wear pattern.





Fig 6 View of Deep Groove ball bearing showing damaged ball race and cage.

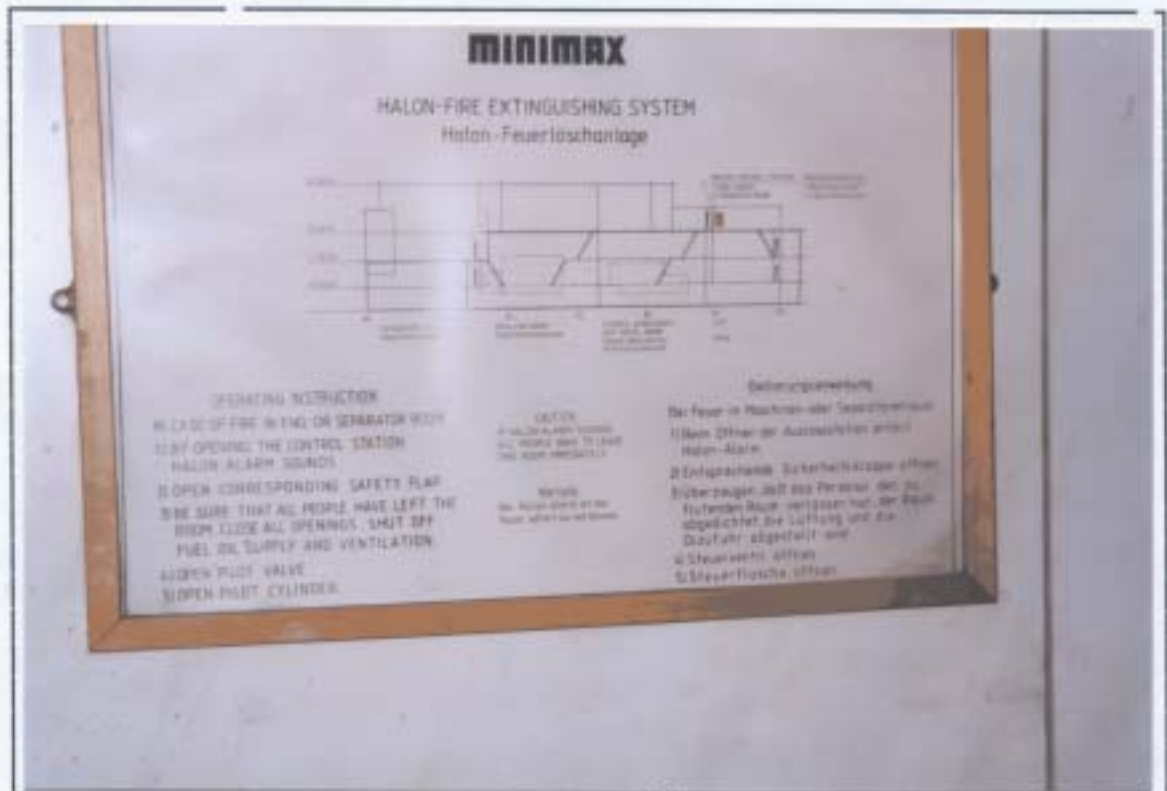

Fig 7 Close-up of Halon system drawing mounted on bulkhead outside Halon Control Station on deck 3.



Fig 8 General view of Halon Control Station on deck 3. Note instructions and locked key box.